



Product catalogue 50Hz

stainless steel submersible pumps & accessories



3"WPS®-CP, 3"WPS® and 3"WPS® P

General Data	4
3"WPS®-CP 1 and 3"WPS® 1	8
3"WPS®-CP 2 and 3"WPS® 2	10
3"WPS®-CP 3 and 3"WPS® 3	12
3"WPS®-CP 5 and 3"WPS® 5	14
Cable Selection	16
Material Specification	18
3"WPS® 3 P	20
3"WPS® 4 P	22
Accessoires	24

4"WPS®, 4"WPS®-CP and 4"WPS® P

General Data	28
4"WPS® 1,5 & 4"WPS® 1,5 N(E)	30
4"WPS® 2,5 and 4"WPS® 2,5 N(E)	32
4"WPS® 4 and 4"WPS® 4 N(E)	34
4"WPS® 7 and 4"WPS® 7 N(E)	36
4"WPS® 13 and 4"WPS® 13 N(E)	38
4"WPS® 20 and 4"WPS® 20 N(E)	40
Material Specification	42
General Data	43
Material Specification	44
4"WPS® 1 P	45
4"WPS® 2 P	47
4"WPS® 3 P	49
4"WPS® 4 P	51
4"WPS® 6 P	53
4"WPS® 8 P	55
4"WPS® 10 P	57
4"WPS® 12 P	59
4"WPS® 16 P	61
Accessories	63

6"WPS®

General Data	64
6"WPS® 16 and 6"WPS® 16 N(E)	66
6"WPS® 30 and 6"WPS® 30 N(E)	70
6"WPS® 45 and 6"WPS® 45 N(E)	74
6"WPS® 60 and 6"WPS® 60 N(E)	78
6"WPS® 75 and 6"WPS® 75 N(E)	82
Material Specification	86
Accessories	87

8"WPS®

General Data	88
8"WPS® 80 en 8"WPS® 80 N(E)	90
8"WPS® 100 en 8"WPS® 100 N(E)	94
8"WPS® 130 en 8"WPS® 130 N(E)	98
8"WPS® 150 en 8"WPS® 150 N(E)	100
Material Specification	102
Accessories	103



10" WPS®

General Data	104
10" WPS® 120 and 10" WPS® 120 N(E)	106
10" WPS® 155 and 10" WPS® 155 N(E)	110
10" WPS® 220 and 10" WPS® 220 N(E)	114
10" WPS® 260 and 10" WPS® 226 N(E)	118
10" WPS® 300 and 10" WPS® 300 N(E)	122
Material Specification.....	126
Accessories.....	127

Motors

Well Pumps 4"WPM Encapsulated Motor	129
Well Pumps 6"WPM Encapsulated Motor	130
Well Pumps 8" and 10"WPM Rewindable Motors	131
Franklin Electric 4" Encapsulated Motor	133
Franklin Electric 6" Encapsulated Motor	134
Franklin Electric Rewindable Motor	135

Control Panels

Cable Sizing.....	138
-------------------	-----

General Data

3" WPS® (-CP)

3" WPS® and 3" WPS®-CP pumps are suitable for domestic applications in intermittent operation:

- Domestic water supply
- Small waterworks
- Irrigation
- Tank applications
- Pressure boosting
- Sampling of monitoring wells

Note: For other applications, please contact Well Pumps.

3" WPS®-CP

3" WPS®-CP pumps offer the following features:

- Pump entirely made out of stainless steel and fits in 3" or larger drilled wells
- Constant pressure with two set pressures possible
- Capacity from 0.2 to 7m³/h and a maximum head of 190m
- Motor rating up to 1,5kW, 140Hz
- Single phase supply to the controller
- Incorporated jam free check valve
- Dry-running protection
- High efficiency of pump and motor
- Excellent resistance to wear
- Soft start
- Overvoltage and undervoltage protection
- Overload protection
- Overtemperature protection.
- Variable speed
- Second set-pressure possible

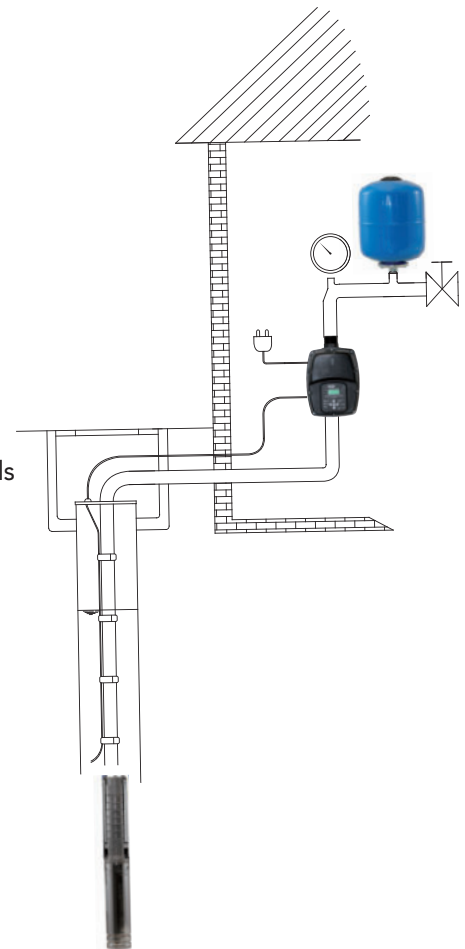

The 3" WPS®-CP pump is fitted with a three phase 230V Well Pumps motor. The 3" WPS®-CP controller needs a single-phase supply and transforms it to a three-phase current to the motor. The controller is equipped with a frequency drive and performs a constant pressure of the flow through a variable speed of the pump. As a consequence, the pump can be set to operate in any duty point in the range between the pump min. and max. performance curves.

In case of a pump fault, an alarm will be indicated on the LCD screen of the 3" WPS®-CP controller.

The 3" WPS®-CP pump is sold as a kit and consists of the following elements:

- A 3" submersible pump WPS® entirely made of stainless steel.
- A WPS® high speed submersible motor able to run at variable frequencies up to 140Hz.
- A WPS®-CP constant pressure controller including a variable speed drive, a flow detection and a pressure sensor.
- A pressure vessel of 8 liter, a valve and a pressure gauge.

3"WPS®

3"WPS® pumps offer the following features:

- Pump entirely made out of stainless steel and fits in 3" or larger drilled wells
- Capacity from 0.2 to 7m³/h and a maximum head of 190m
- Motor rating up to 1,5kW, 140Hz
- Single phase supply
- Incorporated jam free check valve
- Dry-running protection
- High efficiency of pump and motor
- Excellent resistance to wear
- Soft start
- Overvoltage and undervoltage protection
- Overload protection
- Overtemperature protection
- Internal surge arrester

The 3"WPS® pump is fitted with a 230V Well Pumps motor and by means of the built-in frequency converter it is driven at a constant speed of 8200 RPM, 140Hz. Every time the pump is put on the supply (1~230) , a soft start will be performed.

Pump and motor range

3"WPS® and 3"WPS®-CP pump range consist of four flow models: 1, 2, 3, and 5 m³/h. The pump-end is entirely made out of Stainless steel DIN 1.4301, AISI 304.

3"WPS® and 3"WPS®-CP motors are in Stainless steel DIN 1.4301, AISI 304 and available in three motor powers: 600W, 900W and 1500W.

Pipe connection

All pump types have a threaded pipe connection Rp1 ¼".

The 3"WPS®-CP controller has a flow through design. The in- and outlet are 1 ¼" Male.

Pump identification code

Example

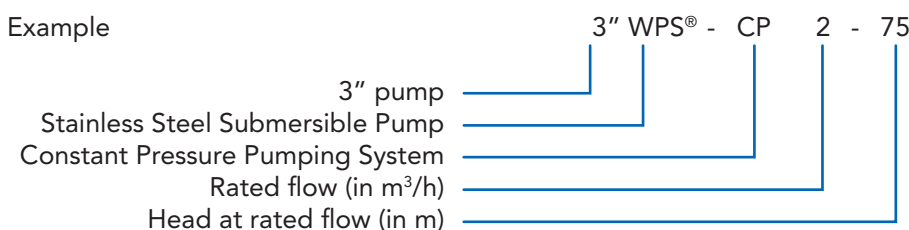

Pumped liquids

3"WPS® and 3"WPS®-CP pumps are designed for pumping thin, clean, non-aggressive and non-explosive liquids, not containing solid particles.

3"WPS® and 3"WPS®-CP pumps are suitable for pumping liquids with a content of sand up to 150 g/m³. A higher content of sand reduce the pump lifetime.

The maximum fluid temperature is 30°C. For higher temperatures, please contact Well Pumps.



3"WPS®(-CP)

Features and benefits

Dry-running protection

3" WPS® and 3" WPS®-CP pumps are protected against dry running.

The **3" WPS®-CP** controller is equipped with a flow sensor that at all times measures the pumped flow. As soon as this flow drops under a minimum value (Q_{min} is about $0,1\text{ m}^3/\text{h}$), the pump will be stopped. Simultaneously, also the absorbed power of the motor is measured. A minimum value of this power ensures cut-out of the pump. Both these measurements ensure in case of lack of water in the borehole, a shutdown of the pump and thus preventing a burnout of the motor.

The **3" WPS®** motor includes a built-in controller that is factory-set with a cut-out power and which continuously tracks the absorbed power of the pump. In case of lack of water in the borehole, the absorbed power by the pump will be reduced below the $P_{cut-out}$. Consequently the pump will be stopped and thus prevent a burnout of the motor. The pump will automatically restart after 20 minutes which gives time to the well to recover. In case of a second dry run the pump will wait for 45 minutes before an automatic restart. At the 3rd dry run, the pump will wait for 6 hours and the fourth time for 24 hours. If a 5th dry run occurs, the pump goes in permanent error and has to be reset by taking off the supply from the motor.

High pump efficiency and Wear resistance

The WPS® pumps are entirely made of stainless steel and ensure a high efficiency meaning low energy consumption and therefore low energy costs.

Due to its stainless steel construction in combination with the high performance NBR seals and bearings, the 3" WPS® and 3" WPS®-CP pumps ensure high wear resistance to sand for long product life.

Excellent starting capabilities

The integrated electronic unit of the 3" WPS® and 3" WPS®-CP controller features soft starting. A soft start reduces the starting current and gives the pump a smooth and steady acceleration.

A soft starter minimizes the risk of wear of the pump and prevents overloading of the supply during start-up.

The high starting reliability also applies in case of low voltage supply.

Overvoltage and undervoltage protection

Overvoltage and undervoltage may occur in case of unstable voltage supply.

The integrated protection of all three motor versions prevents damage to the motor in case the voltage moves outside the permissible voltage range.

The 3" WPS®-CP pump will be cut out if voltage falls below 185V or rises above 260V and for the 3" WPS® models below 160V or over 260V. The motor will restart automatically when the voltage is reestablished within the permissible voltage range.

Therefore no extra protection relay is needed.

Overload protection

Exposure of the pump to heavy load causes the current consumption to rise. When the maximum allowed current is exceeded, the pump will be stopped.

Also a locked rotor will automatically be detected and the power supply cut out. Consequently, no extra motor protection is needed.

The 3" WPS® pumps have an extra feature that automatically reduce the speed of the pump when overload occurs. Lower speed means lower power and thus reduction of the absorbed amps. In the case the pump is running at 60Hz and still overloading, the pump will stop and automatically restart after one hour.

Overtemperature protection

The electronic unit of the 3"WPS® and 3"WPS®-CP controller has a built-in temperature sensor. The 3"WPS®-CP controller will cut out the pump when the temperature of the fluid rises over its limit of 55°C. The error code 'Inverter Error' will be mentioned on the display of the 3"WPS®-CP controller. When the temperature has dropped to 45°C, the motor is automatically restarted. The 3"WPS® motor will reduce the speed as soon as the internal temperature in the motor reaches 80°C. This way the absorbed amps and consequently the dissipated heat of the motor will be reduced. In case that at 60Hz the temperature is still not reduced, the pump will shut off and restart automatically after one hour.

Protection against lightning

A surge arrester is built in the motor of the 3"WPS® pumps and is designed to protect the motor from damaging effects of spikes and transients caused by small lightning, electrical motor cycling or any other sudden change in electrical power flow on the supply line.

Reliability

The motors have been constructed with a view to high reliability and have the following features:

- Top quality high speed ball bearings.
- An efficient internal food grade oil circulation in the motor transfers the heat away from the rotor, stator and ball bearings and ensures an optimum operating condition for the motor.

Variable speed (only for 3"WPS®-CP units)

The 3"WPS®-CP controller enables continuously variable speed control within the 5740 and 8200 rpm. The pump can operate in any duty point in the range between the 5740 and 8200 rpm performance curves of the pump. Consequently, the pump performance can be adapted to any specific requirement. On the basis of a required head the speed of the motor is calculated.

Auxiliary contact for Second set-pressure or Remote on/off switch (only for 3"WPS®-CP units)

The 3"WPS®-CP controller is standard equipped with an auxiliary contact that can be activated by changing a specific parameter in the programming of the 3"WPS®-CP controller. The auxiliary contact can be used as a remote on/off switch (f.e. only run the pump when the irrigation is running, extra protection of the pump against dry running in a tank or cistern with a float switch, ...) or to create a second constant pressure level (f.e. higher pressure level when the irrigation system runs, lower pressure level to back-wash a water treatment system, ...)

Performance Curves

3" WPS® (-CP)

Performance Curves 3" WPS® 1 and 3" WPS®-CP 1

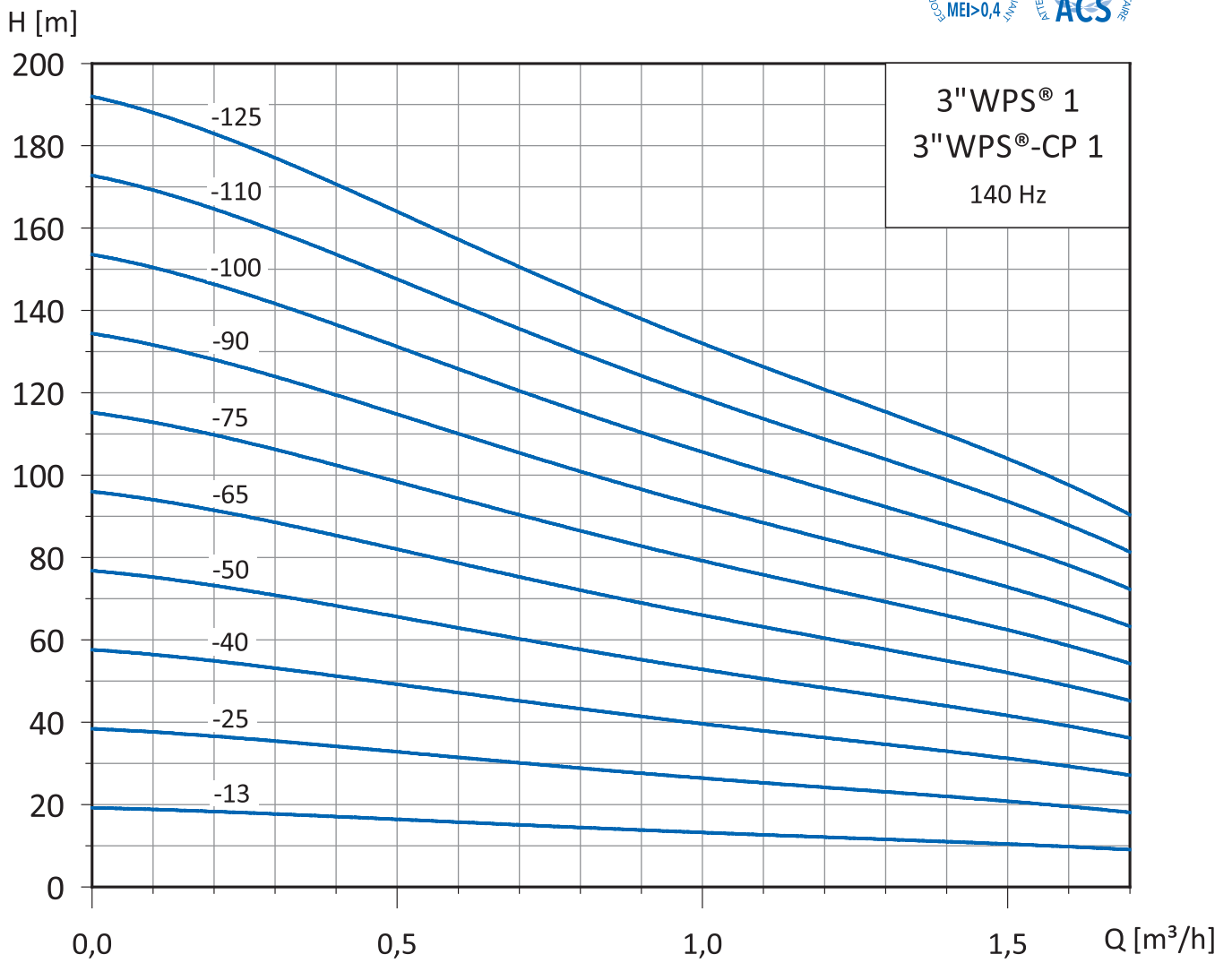

Selection Chart 3"WPS® 1 and 3"WPS®-CP 1

Pump Type	Max. Pump Power [kW]	Flow [m³/h]				Max. head [m] at 0 m³/h	Full load current	
		0,5	1	1,5	2		Motor [A]	Supply [A]
3" WPS®-CP 1-13	0,15	17	13	10	6	20	1,9	3,3
3" WPS® 1-25	0,29	33	26	21	12	39	2,3	3,9
3" WPS®-CP 1-25								3,8
3" WPS® 1-40	0,44	50	40	31	18	59	2,7	4,8
3" WPS®-CP 1-40								4,7
3" WPS® 1-50	0,58	66	53	42	24	78	3,1	5,6
3" WPS®-CP 1-50								5,4
3" WPS® 1-65	0,73	83	66	52	30	98	4,1	7,2
3" WPS®-CP 1-65								7,1
3" WPS® 1-75	0,87	100	79	62	36	117	4,6	8,0
3" WPS®-CP 1-75								8,0
3" WPS® 1-90	1,02	116	92	73	42	137	6,1	10,5
3" WPS®-CP 1-90								10,6
3" WPS® 1-100	1,16	133	106	83	48	156	6,5	11,2
3" WPS®-CP 1-100								11,3
3" WPS® 1-110	1,31	149	119	94	54	176	6,9	11,9
3" WPS®-CP 1-110								12,0
3" WPS® 1-125	1,45	166	132	104	60	195	7,2	12,5
3" WPS®-CP 1-125								12,5

Dimensions and Weights 3"WPS® 1 and 3"WPS®-CP 1

Pump Type	Num. of stage	Max Pump power P ₂ [kW]	Pump data				Kit CP	
			A [mm]	B [mm]	C [mm]	Weight [kg]	Dim. [cm]	Weight [kg]
3"WPS®-CP 1-13	1	0,15	160	210	370	5,1	65x32x22	11,2
3"WPS® 1-25	2	0,29	180	800	980	7,7	65x32x22	10,4
3"WPS®-CP 1-25								
3"WPS® 1-40	3	0,44	200	800	1000	7,9	65x32x22	3,8
3"WPS®-CP 1-40								
3"WPS® 1-50	4	0,58	220	800	1020	8,1	65x32x22	11,8
3"WPS®-CP 1-50								
3"WPS® 1-65	5	0,73	240	830	1070	9	65x32x22	12,7
3"WPS®-CP 1-65								
3"WPS® 1-75	6	0,87	260	830	1090	9,2	65x32x22	12,9
3"WPS®-CP 1-75								
3"WPS® 1-90	7	1,02	280	860	1140	10	65x32x22	13,7
3"WPS®-CP 1-90								
3"WPS® 1-100	8	1,16	300	860	1160	10,2	65x32x22	13,9
3"WPS®-CP 1-100								
3"WPS® 1-110	9	1,31	320	860	1180	10,4	65x32x22	14,1
3"WPS®-CP 1-110								
3"WPS® 1-125	10	1,45	340	860	1200	10,6	65x32x22	14,3
3"WPS®-CP 1-125								

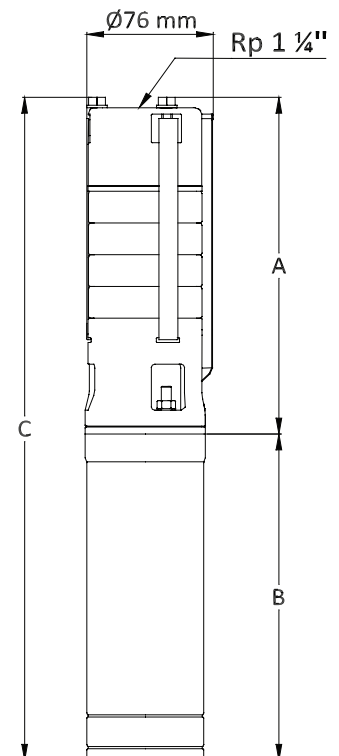

Performance Curves

3"WPS®(-CP)

Performance Curves 3"WPS® 2 and 3"WPS®-CP 2

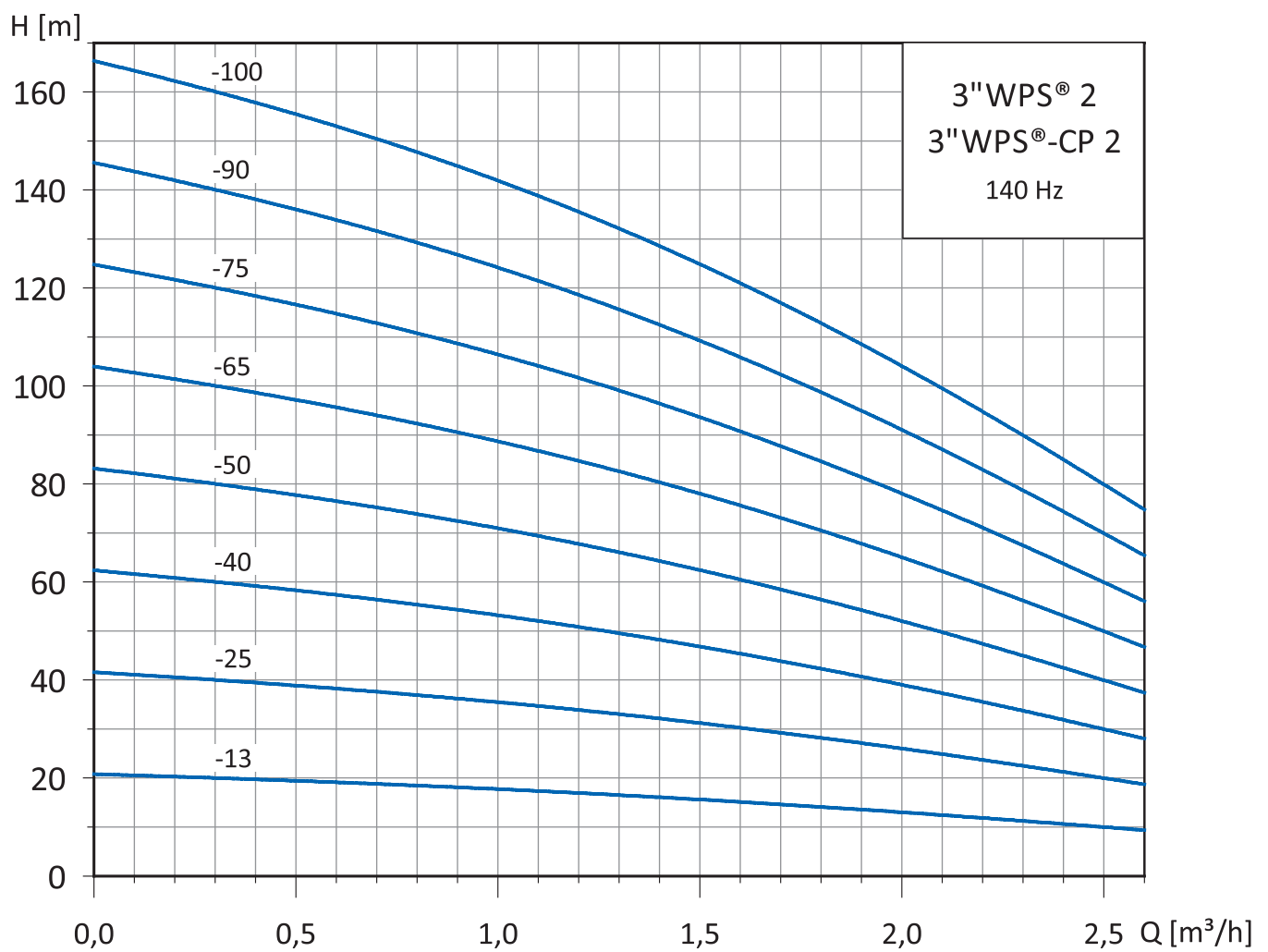

Selection Chart 3"WPS® 2 and 3"WPS®-CP 2

Pump Type	Max. Pump Power [kW]	Flow [m³/h]					Max. head [m] at 0 m³/h	Full load current	
		0,5	1	1,5	2	2,5		Motor [A]	Supply [A]
3" WPS®-CP 2-13	0,19	20	18	16	13	10	21	2,0	3,5
3" WPS® 2-25	0,37	39	36	31	26	20	42	2,5	4,5
3" WPS®-CP 2-25									4,4
3" WPS® 2-40	0,56	59	53	47	39	30	62	3,1	5,5
3" WPS®-CP 2-40									5,4
3" WPS® 2-50	0,74	78	71	62	52	40	83	4,1	7,0
3" WPS®-CP 2-50									7,1
3" WPS® 2-65	0,90	98	89	78	65	50	104	4,7	8,2
3" WPS®-CP 2-65									8,2
3" WPS® 2-75	1,11	117	107	93	78	60	125	6,1	10,5
3" WPS®-CP 2-75									10,6
3" WPS® 2-90	1,29	137	124	109	91	70	145	6,8	11,7
3" WPS®-CP 2-90									11,8
3" WPS® 2-100	1,48	156	142	124	104	80	166	7,2	12,5
3" WPS®-CP 2-100									12,5

3"WPS®(-CP)

Dimensions and Weights 3"WPS® 2 and 3"WPS®-CP 2

Pump Type	Num. of stage	Max Pump power P ₂ [kW]	Pump data				Kit CP	
			A [mm]	B [mm]	C [mm]	Weight [kg]	Dim. [cm]	Weight [kg]
3"WPS®-CP 2-13	1	0,19	160	210	370	5,1	65x32x22	11,2
3"WPS® 2-25	2	0,37	180	800	980	7,7	65x32x22	10,4
3"WPS®-CP 2-25								
3"WPS® 2-40	3	0,56	200	800	1000	7,9	65x32x22	11,6
3"WPS®-CP 2-40								
3"WPS® 2-50	4	0,74	220	830	1050	8,9	65x32x22	12,6
3"WPS®-CP 2-50								
3"WPS® 2-65	5	0,90	240	830	1070	9,1	65x32x22	12,8
3"WPS®-CP 2-65								
3"WPS® 2-75	6	1,11	260	860	1120	10,0	65x32x22	13,7
3"WPS®-CP 2-75								
3"WPS® 2-90	7	1,29	280	860	1140	10,2	65x32x22	13,9
3"WPS®-CP 2-90								
3"WPS® 2-100	8	1,48	300	860	1160	10,4	65x32x22	14,1
3"WPS®-CP 2-100								

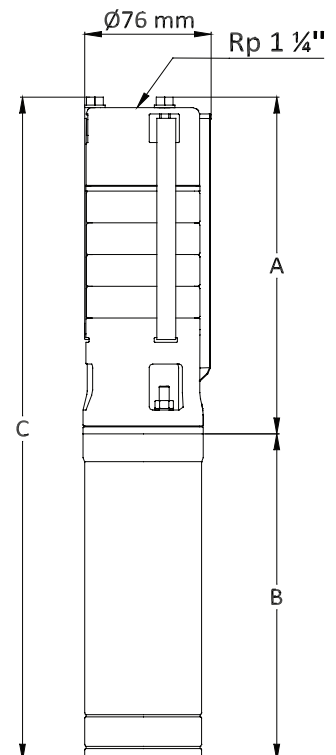

Performance Curves

3"WPS®(-CP)

Performance Curves 3"WPS® 3 and 3"WPS®-CP 3

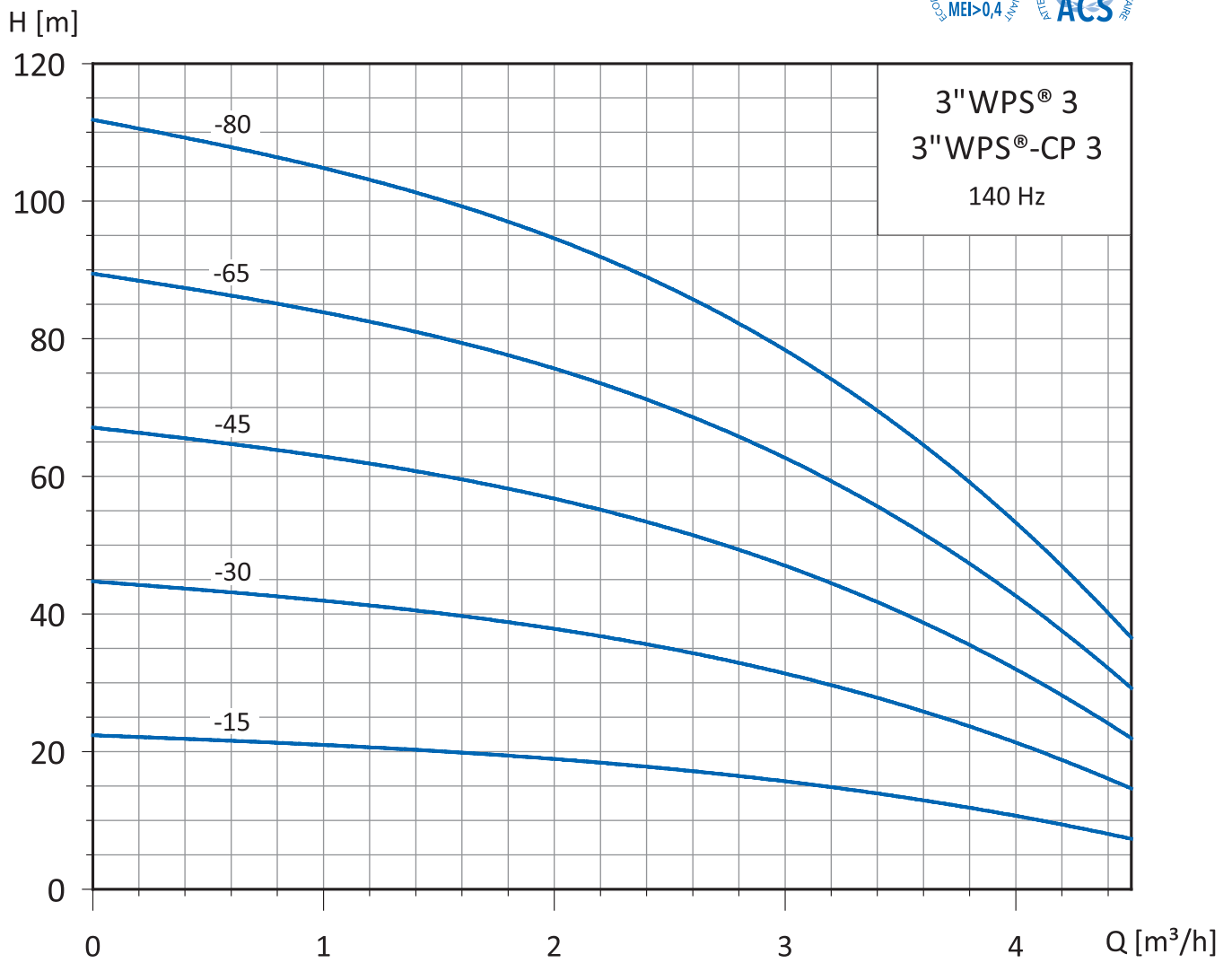

Selection Chart 3"WPS® 3 and 3"WPS®-CP 3

Pump Type	Max. Pump Power [kW]	Flow [m³/h]						Max. head [m] at 0 m³/h	Full load current	
		1	2	2,5	3	3,5	4		Motor [A]	Supply [A]
3" WPS® 3-15 3" WPS®-CP 3-15	0,29	21	19	17	16	13	10	22	2,8	4,9
3" WPS® 3-30 3" WPS®-CP 3-30	0,58	42	37	34	31	26	21	45	3,1	5,5
3" WPS® 3-45 3" WPS®-CP 3-45	0,87	62	56	52	47	40	31	67	4,6	8,0
3" WPS® 3-65 3" WPS®-CP 3-65	1,16	83	74	69	62	53	42	90	6,3	10,8
3" WPS® 3-80 3" WPS®-CP 3-80	1,45	104	93	86	78	66	52	112	7,1	12,3

3"WPS®(-CP)

Dimensions and Weights 3"WPS® 3 and 3"WPS®-CP 3

Pump Type	Num. of stage	Max Pump power P ₂ [kW]	Pump data				Kit-CP	
			A [mm]	B [mm]	C [mm]	Weight [kg]	Dim. [cm]	Weight [kg]
3"WPS® 3-15 3"WPS®-CP 3-15	1	0,29	160	800	960	6,5		
3"WPS® 3-30 3"WPS®-CP 3-30	2	0,58	180	800	980	6,8	65x32x22	11,2
3"WPS® 3-45 3"WPS®-CP 3-45	3	0,87	200	830	1030	8,7	65x32x22	12,4
3"WPS® 3-65 3"WPS®-CP 3-65	4	1,16	220	860	1080	9,7	65x32x22	13,4
3"WPS® 3-80 3"WPS®-CP 3-80	5	1,45	240	860	1100	9,9	65x32x22	13,6

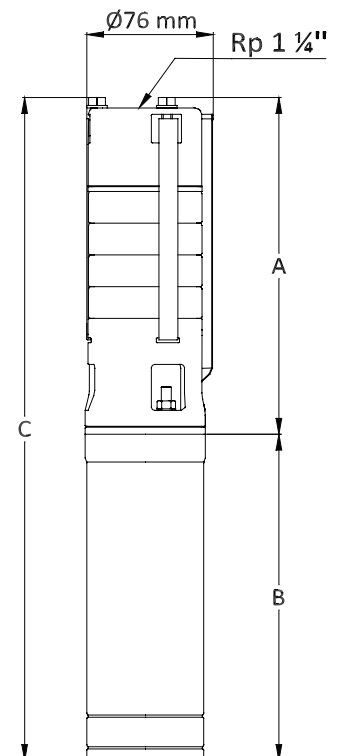

Performance Curves

3"WPS®(-CP)

Performance Curves 3"WPS® 5 and 3"WPS®-CP 5

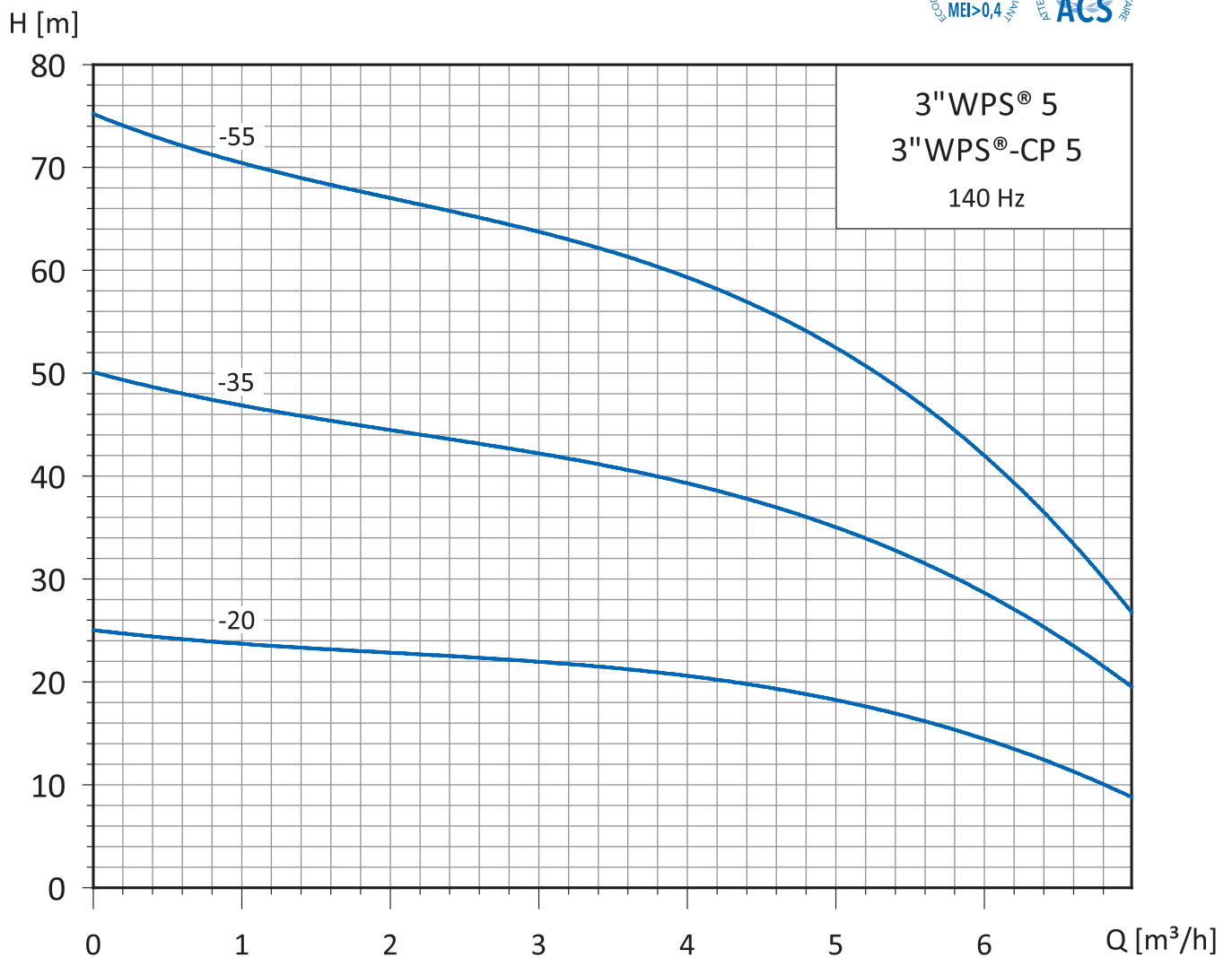

Selection Chart 3"WPS® 5 and 3"WPS®-CP 5

Pump Type	Max. Pump Power [kW]	Flow [m³/h]						Max . head [m] at 0 m³/h	Full load current	
		1	2	3	4	5	6		Motor [A]	Supply [A]
3" WPS® 5-20 3" WPS®-CP 5-20	0,45	24	23	21	21	18	15	25	3,2	5,6
3" WPS® 5-35 3" WPS®-CP 5-35	0,90	47	44	42	39	35	29	50	4,7	8,2
3" WPS® 5-55 3" WPS®-CP 5-55	1,35	70	67	64	59	53	42	75	7,2	12,5

Dimensions and Weights 3"WPS® 5 and 3"WPS®-CP 5

Pump Type	Num. of stage	Max Pump power P ₂ [kW]	Pump data				Kit-CP	
			A [mm]	B [mm]	C [mm]	Weight [kg]	Dim. [cm]	Weight [kg]
3"WPS® 5-15 3"WPS®-CP 5-15	1	0,45	160	800	960	7,5	65x32x22	11,2
3"WPS® 5-30 3"WPS®-CP 5-30	2	0,90	180	830	1010	8,5		
3"WPS® 5-45 3"WPS®-CP 5-45	3	1,35	200	860	1060	9,5	65x32x22	13,2
				270	470	7,1		

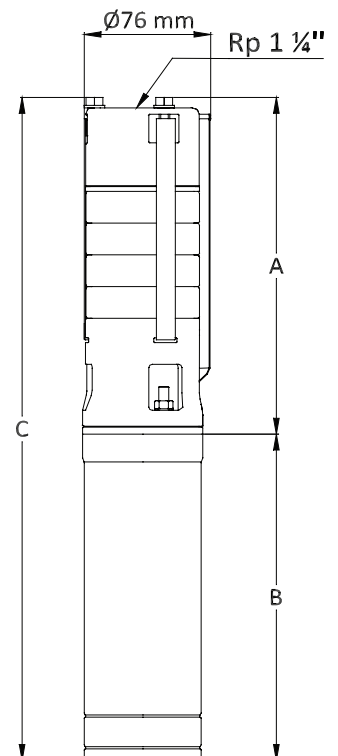

Technical Data

3" WPS® (CP)

Cable selection

3" WPS®

Submersible drop cable to the motor (single phase)

The table below shows the maximum length of the submersible drop cable between the supply and the motor for the different cable sizes and motor powers.

The cross-sections of the cable are calculated according to a 3% voltage drop (IEC 60364:2001). The pump will cut out if the supply voltage falls below 160 V.

Pump Type	P ₂ [kW]	I _n [A]	Maximum cable length [m]. Cable section AWG/mm ²								
			14 AWG			12 AWG		10 AWG		8 AWG	
			1,5	2,1	2,5	3,3	4	5,3	6	8,4	10
3" WPS® 1-40	0,44	3,9	120	168	200	264	320	424	480	672	800
3" WPS® 1-50	0,58	4,8	98	137	163	215	260	345	390	546	650
3" WPS® 1-65	0,73	6,0	78	109	130	172	208	276	312	437	520
3" WPS® 1-75	0,87	7,1	66	92	110	145	176	233	264	369	439
3" WPS® 1-90	1,02	8,1	58	81	69	127	154	204	231	324	385
3" WPS® 1-100	1,16	9,1	51	72	86	113	137	182	206	288	343
3" WPS® 1-110	1,31	10,0	47	66	78	103	125	165	187	262	312
3" WPS® 1-125	1,45	11,8	40	56	66	87	106	140	159	222	264
3" WPS® 2-25	0,37	3,6	130	182	217	286	347	459	520	728	867
3" WPS® 2-40	0,56	5,0	94	131	156	206	250	331	374	524	624
3" WPS® 2-50	0,74	5,9	79	111	132	175	212	280	317	444	529
3" WPS® 2-65	0,90	7,2	65	91	108	143	173	230	260	364	433
3" WPS® 2-75	1,11	8,9	53	74	88	116	140	186	210	294	351
3" WPS® 2-90	1,29	9,9	47	66	79	104	126	167	189	265	315
3" WPS® 2-100	1,48	12,0	39	55	65	86	104	138	156	218	260
3" WPS® 3-30	0,58	4,5	104	146	173	229	277	367	416	582	693
3" WPS® 3-45	0,87	6,0	78	109	130	172	208	276	312	437	520
3" WPS® 3-65	1,16	8,2	57	80	95	126	152	202	228	320	381
3" WPS® 3-80	1,45	10,2	46	64	76	101	122	162	184	257	306
3" WPS® 5-20	0,45	4,0	117	164	195	257	312	413	468	655	780
3" WPS® 5-35	0,90	7,6	62	86	103	135	164	218	246	345	411
3" WPS® 5-55	1,35	11,0	43	60	71	94	113	150	170	238	284

Cable selection

3"WPS®-CP

Submersible drop cable to the motor (three phase)

The table below shows the maximum length of the submersible drop cable between the controller and the motor for the different cable sizes and motor powers.

The cross-sections of the cable are calculated according to a 3% voltage drop (IEC 60364:2001).

The pump will cut out if the supply voltage falls below 185 V.

Pump Type	P ₂ [kW]	I _n [A]	Maximum cable length [m]. Cable section AWG/mm ²								
			14 AWG			12 AWG		10 AWG		8 AWG	
			1,5	2,1	2,5	3,3	4	5,3	6	8,4	10
3"WPS®-CP 1-40	0,44	2,7	125	175	209	276	334	443	501	701	835
3"WPS®-CP 1-50	0,58	3,1	109	153	182	240	291	385	436	611	727
3"WPS®-CP 1-65	0,73	4,1	82	115	137	181	220	291	330	462	550
3"WPS®-CP 1-75	0,87	4,6	74	103	123	162	196	260	294	412	490
3"WPS®-CP 1-90	1,02	6,1	55	78	92	122	148	196	222	310	370
3"WPS®-CP 1-100	1,16	6,3	54	75	89	118	143	190	215	301	358
3"WPS®-CP 1-110	1,31	6,5	52	73	87	114	139	184	208	291	347
3"WPS®-CP 1-125	1,45	6,9	49	69	82	108	131	173	196	274	327
3"WPS®-CP 2-25	0,37	2,5	135	189	225	298	361	478	541	757	902
3"WPS®-CP 2-40	0,56	3,1	109	153	182	240	291	385	436	611	727
3"WPS®-CP 2-50	0,74	4,2	81	113	134	177	215	284	322	451	537
3"WPS®-CP 2-65	0,90	4,7	72	101	120	158	192	254	288	403	480
3"WPS®-CP 2-75	1,11	6,0	56	79	94	124	150	199	225	316	376
3"WPS®-CP 2-90	1,29	6,9	49	69	82	108	131	173	196	274	327
3"WPS®-CP 2-100	1,48	7,3	46	65	77	102	124	164	185	259	309
3"WPS®-CP 3-30	0,58	2,8	121	169	201	266	322	427	483	676	805
3"WPS®-CP 3-45	0,87	4,1	82	115	137	181	220	291	330	462	550
3"WPS®-CP 3-65	1,16	5,5	61	86	102	135	164	217	246	344	410
3"WPS®-CP 3-80	1,45	6,6	51	72	85	113	137	181	205	287	342
3"WPS®-CP 5-20	0,45	2,8	121	169	201	266	322	427	483	676	805
3"WPS®-CP 5-35	0,90	4,7	72	101	120	158	192	254	288	403	480
3"WPS®-CP 5-55	1,35	7,4	46	64	76	101	122	161	183	256	305

In case the total length of the electrical power cable between controller and motor exceeds 100m, an extra filter to protect the motor from burning is required. See accessories.

Supply cable to the controller (single phase)

In case you want a longer electrical cable, you must check the cable section following the table below. Maximal cable length for specific cable sections:

Motor Size	1,5 mm ²	2,5 mm ²	4 mm ²	6 mm ²
600 W	70 m	120 m	180 m	270 m
900 W	50 m	80 m	125 m	190 m
1500 W	35 m	60 m	90 m	140 m

Technical Data

Material specification

3" WPS P

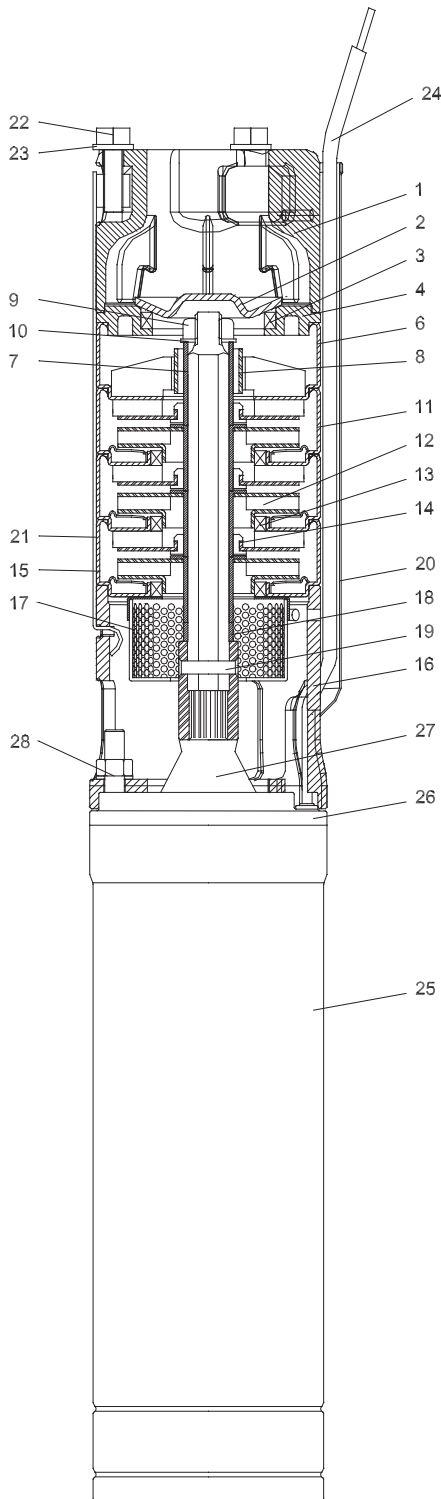

Pos.	Component	Material	Material code
1	Discharge Chamber	Stainless Steel	AISI 304 - 1.4301
2	Valve Cone	Stainless Steel	AISI 304 - 1.4301
3	Valve Seat	Stainless Steel/NBR	AISI 304 - 1.4301
4	Retainer for Valve Seat	Stainless Steel	AISI 304 - 1.4301
5	Up-trust Washer	Teflon	PTFE
6	Top Diffuser	Stainless Steel	AISI 304 - 1.4301
7	Top Spacer	Stainless Steel	AISI 304 - 1.4301
8	Top Bearing	Stainless Steel/NBR	AISI 304 - 1.4301
9	Nut M8	Stainless Steel	AISI 304 - 1.4301
10	Washer M8	Stainless Steel	AISI 304 - 1.4301
11	Diffuser	Stainless Steel	AISI 304 - 1.4301
12	Impeller	Stainless Steel	AISI 304 - 1.4301
13	Neck Ring	Stainless Steel/NBR	AISI 304 - 1.4301
14	Intermediate Bearing	NBR	
15	Bottom Diffuser	Stainless Steel	AISI 304 - 1.4301
16	Section interconnector	Stainless Steel	AISI 304 - 1.4301
17	Strainer	Stainless Steel	AISI 304 - 1.4301
18	First Spacer	Stainless Steel	AISI 304 - 1.4301
19	Shaft with coupling	Stainless Steel	AISI 304 - 1.4301
20	Cable Gard	Stainless Steel	AISI 304 - 1.4301
21	Strap	Stainless Steel	AISI 304 - 1.4301
22	Bolt M6	Stainless Steel	AISI 304 - 1.4301
23	Washer M6	Stainless Steel	AISI 304 - 1.4301
24	Motor Lead with plug		
25	Motor Stator	Stainless Steel	AISI 304 - 1.4301
26	Motor Top Cover	Stainless Steel	AISI 304 - 1.4301
27	Shaft Seal	NBR	
28	Nut and Washer M6	Stainless Steel	AISI 304 - 1.4301

3"WPS® P pumps are constructed out of a stainless steel pump body, copper-casted suction interconnector/discharge and are equipped with polyacetal impellers and polycarbonate diffuser parts.

Pumps are suitable for both continuous and intermittent operation for a variety of applications:

- Domestic water supply
- Garden irrigation
- Tank applications

Note: for other applications, please contact Well Pumps

3"WPS® P

3"WPS® P pumps offer the following features:

- Discharge Chamber and Suction Interconnector are copper casted parts.
- Impellers are floating type and made out of polyacetal.
This leads to a strong pump with a resistance against abrasion.
The maximum sand content up to 300 g/m³.
- The maximum pumped fluid temperature is 35°C.
- The shaft and coupling are constructed out of stainless steel AISI 304.
- Motor adaptor following NEMA standard.
- All pumps are standard equipped with 30m 3G1mm² blue submersible flat cable.
- Every pump is supplied with a start control box.
- Maximum immersion depth is 80m.

Pump and motor range

3"WPS® P pump range consists of two models: 3 and 4 m³/h. Pumps are mounted with a 3"WPS® rewindable oil filled submersible motor with all parts in contact with water made of corrosion resistant steel. Power range from 0,37 up to 1,1 kW single phase 1x230V, 50Hz.

Pipe connection

All 3"WPS® P pumps have an outlet of Rp 1".

Pump identification code

Example

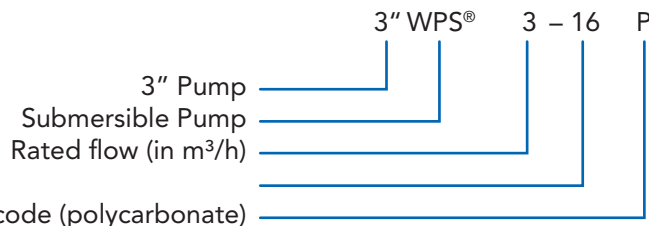

Curve condition

- Curve tolerances according to ISO 9906:2012, class 3B
- The performance curves show pump performance at actual speed of the standard motor range.
- The measurements were made with airless water at a temperature of 20°C and a kinematic viscosity of 1 mm²/s (1 cSt).
- Q/H: The curves are inclusive of valve and inlet losses at the actual speed.



Performance Curves

Performance Curves 3"WPS® 3 P

3"WPS® 3 P

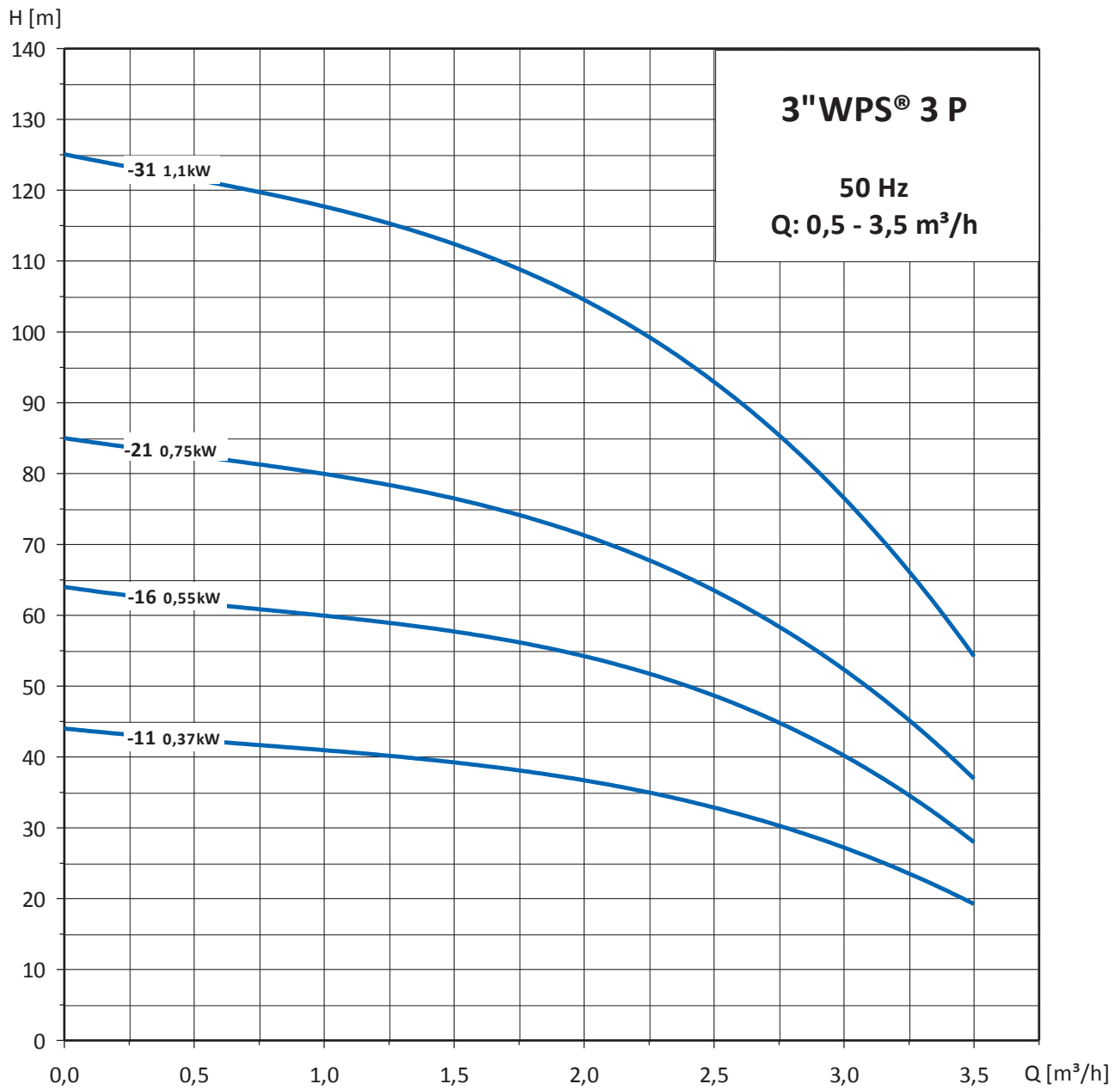

Selection Chart 3"WPS® 3 P

Pump Type	Pump Power P ₂		Flow [m ³ /h]						Full load current 1x230V
	[kW]	[HP]	0	1,0	2,0	2,5	3	3,5	
3"WPS® 3-11 P	0,37	0,50	44	41	37	32	28	19	3,4
3"WPS® 3-16 P	0,55	0,75	64	60	54	49	40	28	4,2
3"WPS® 3-21 P	0,75	1,00	85	80	71	64	52	37	5,6
3"WPS® 3-31 P	1,10	1,50	125	118	104	93	77	54	7,8

Dimensions and Weights 3"WPS® 3 P

Pump Type	Pump Power P ₂		Pump data			Weight [kg]	
	[kW]	[HP]	A [mm]	B [mm]	C [mm]	Pump end	Electro-pump
3"WPS® 3-11 P	0,37	0,50	483	338	821	2,1	7,7
3"WPS® 3-16 P	0,55	0,75	613	368	981	2,5	8,9
3"WPS® 3-21 P	0,75	1,00	768	408	1176	3,2	10,7
3"WPS® 3-31 P	1,10	1,50	1029	493	1522	4,1	14,1

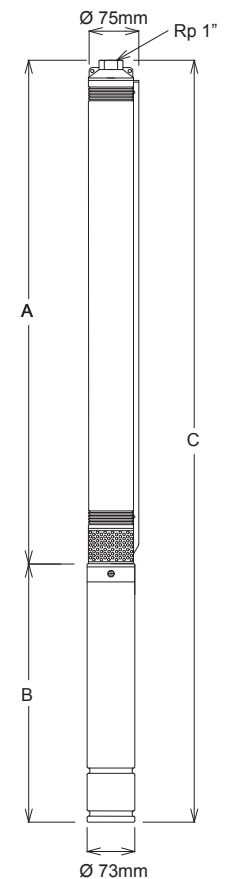

Performance Curves

Performance Curves 3"WPS® 4 P

3"WPS® P

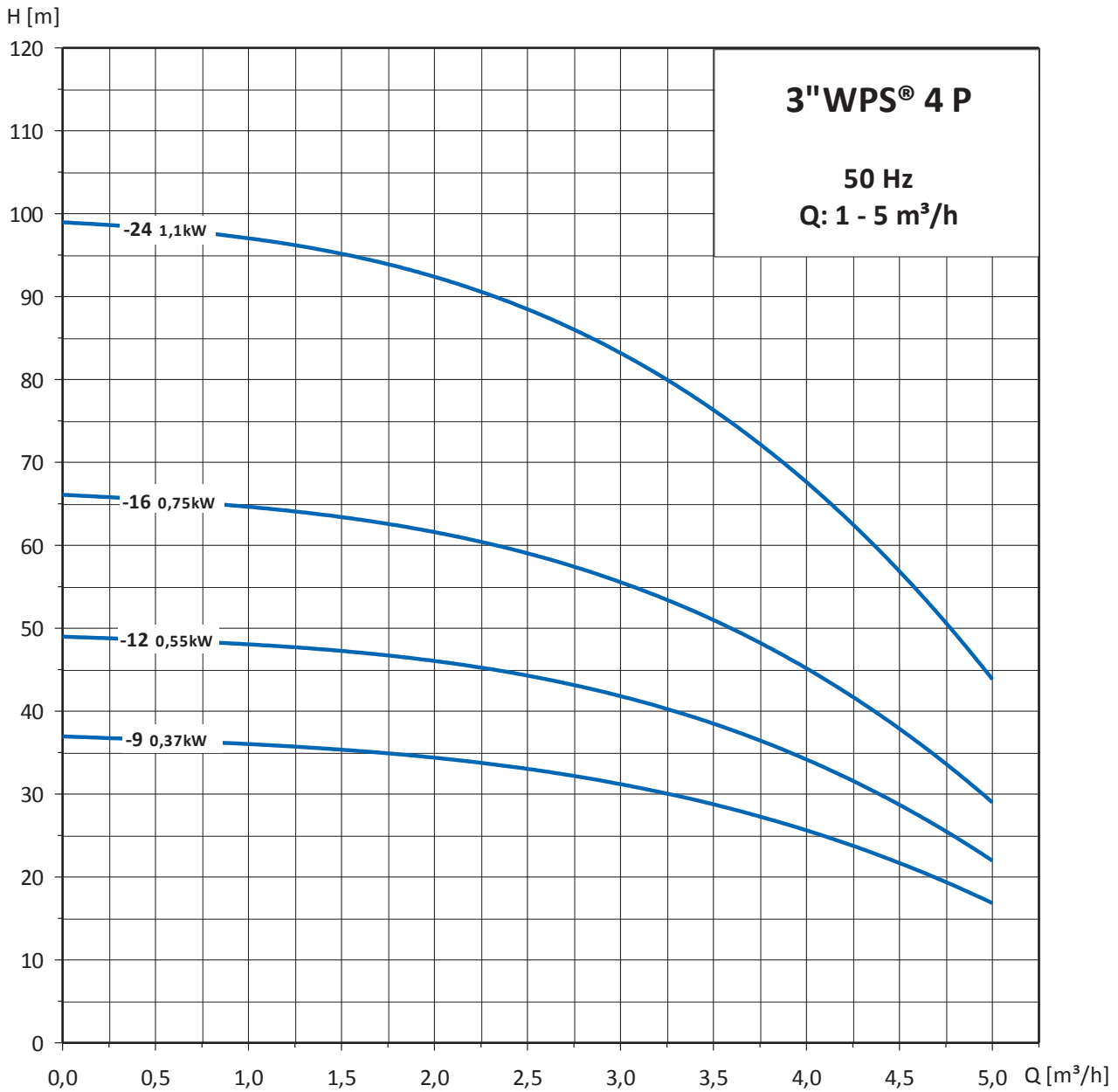

Selection Chart 3"WPS® 4 P

Pump Type	Pump Power P ₂		Flow [m ³ /h]						Full load current 1x230V
	[kW]	[HP]	0	1,0	2,0	3,0	4,0	5,0	
3"WPS® 4-9 P	0,37	0,50	37	36	34	32	25	17	3,4
3"WPS® 4-12 P	0,55	0,75	49	48	46	42	34	22	4,2
3"WPS® 4-16 P	0,75	1,00	66	65	61	56	45	29	5,6
3"WPS® 4-24 P	1,10	1,50	99	97	92	84	67	44	7,8

Dimensions and Weights 3"WPS® 4 P

Pump Type	Pump Power P ₂		Pump data			Weight [kg]	
	[kW]	[HP]	A [mm]	B [mm]	C [mm]	Pump end	Electro-pump
3"WPS® 4-9 P	0,37	0,50	468	338	806	2,0	7,6
3"WPS® 4-12 P	0,55	0,75	599	368	967	2,3	8,7
3"WPS® 4-16 P	0,75	1,00	757	408	1165	2,8	10,3
3"WPS® 4-24 P	1,10	1,50	1026	493	1519	3,9	13,9

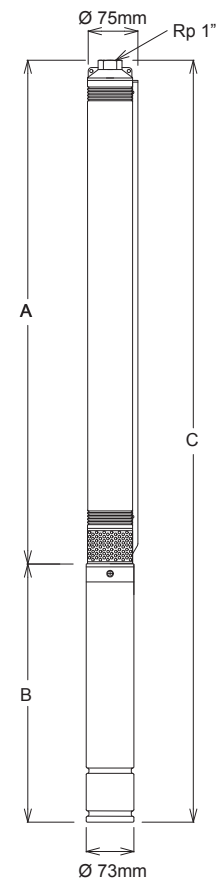

Accessories

3" WPS® (-CP)

Submersible drop cable to the motor (drinking water quality)

3" WPS®-CP

4-core submersible cable including earth conductor (three phase motor). This blue cable is approved for drinking water applications (KTW approval). When ordering please state length [m]



Description	Cross Section of leads	Reference
Submersible cable 4G1,5	1,5 mm ²	9105
Submersible cable 4G2,5	2,5 mm ²	9106
Submersible cable 4G4	4 mm ²	9107
Submersible cable 4G6	6 mm ²	9108

3" WPS®

3-core submersible cable including earth conductor (single phase supply). This blue cable is approved for drinking water applications (KTW approval). When ordering please state length [m]



Description	Cross Section of leads	Reference
Submersible cable 3G1,5	1,5 mm ²	9101
Submersible cable 3G2,5	2,5 mm ²	9102
Submersible cable 3G4	4 mm ²	9103
Submersible cable 3G6	6 mm ²	9104

Submersible cable joint kit

For watertight shrink-joining of motor cable and submersible drop cable (round or flat cable). The joint is ready for use after a few minutes and requires no long hardening time as do resin joints.



Description	Cross Section of leads	Reference
Submersible cable joint kit 1,5-2,5	1,5-2,5 mm ²	9200
Cable joint 1,5-2,5 mm ² fitted to the drop cable	1,5-2,5 mm ²	9300
Submersible cable joint kit 4-6	4-6 mm ²	9201
Cable joint 4-6 mm ² fitted to the drop cable	4-6 mm ²	9301

Straining Wire

The stainless steel wire retains the submersible pump. Special openings are made in the discharge chamber to fix the wire to the pump. When ordering please state the requested length [m].



Material	Diameter	Reference
Stainless steel DIN W.-Nr. 1.4401, Aisi 316	Ø 3 mm	71003

Wire clamps



Two units are needed per loop. This means per installation 4 wire clamps are recommended.

Material	Diameter	Reference
Stainless steel DIN W.-Nr. 1.4401, Aisi 316	Ø 3 mm	71103

Filters



1. Motor side (only for 3"WPS®-CP): When the drop cable between the controller and the pump exceeds more than 100m, an extra filter to protect the motor from burning is required.

Description	Max. length drop cable	Reference
WPS® 200MF Filter	200 m	7200
WPS® 400MF Filter	400 m	7210

2. Supply side (for both 3"WPS®-CP and 3"WPS® pumps) : Radio frequency interference is the radiation or conduction of radio frequency energy (or electronic noise) produced by electrical and electronic devices at levels that interfere with the operation of adjacent equipment. In case you experience phenomena, please install the WPS® RFI Power Line Filter.

Description	Reference
WPS® RFI Power Line Filter	7220

Cooling Shrouds

The cooling shrouds are designed to ensure a sufficient flow velocity past the motor in order to provide sufficient cooling. For the following cases a cooling shroud is recommended:

- horizontal or vertical installation in a tank
- installation of the pump in the screen from the well
- installation in big sized well not ensuring enough cooling velocity. See table.

Minimum flow required for motor cooling in water up to 20°C.	
Casing or sleeve I.D. [mm (inches)]	3" motor, cooling flow 8 cm/sec [m³/h]
78 (3")	0,2
102 (4")	1,1
127 (5")	2,4
152 (6")	4,0

To the shroud itself, a screen can be added. In case of horizontal installation a set of supports are available. The screen can be changed by an adaptor with floating screen ensuring water intake about 20cm under the water level and prevent clogging of the pump due to sand or other sediments on the bottom of the tank, lake, ...

3"WPS®-CP

3"WPS®(-CP)

Description	Material	Pump with motor	Reference
Shroud Ø88x350mm	1.4301 AISI304	600W	73020
Shroud Ø88x450mm	1.4301 AISI304	900W - 1500W	73030

3"WPS®

Description	Material	Pump with motor	Reference
Shroud Ø88x900mm	1.4301 AISI304	All types	73010

3"WPS® and 3" WPS® CP

Description	Material	Pump with motor	Reference
Screen Ø88x90mm	1.4301 AISI304	All types	73300
Floating screen	1.4301 AISI304	All types	73310

Description	Material	Reference
Set of supports for horizontal installation	1.4301 AISI304	73400



Complete horizontal installation of 3"WPS®-CP pump with shroud, screen and set of support

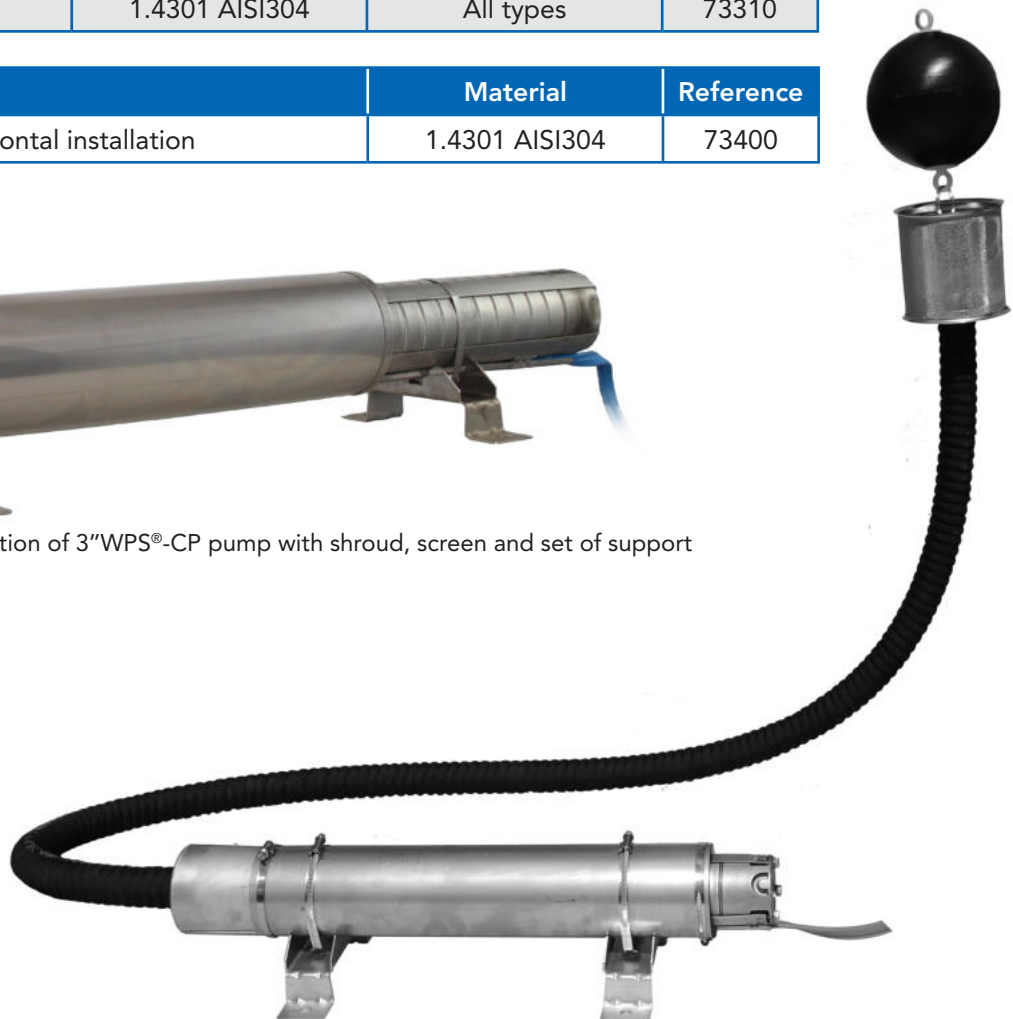

3" WPS® - CP pump with floating screen

General Data

4" WPS® pumps are constructed of stainless steel throughout and are suitable for both continuous and intermittent operation for a variety of applications:

- Domestic and general water supply
- Small waterworks and fountains
- Irrigation
- Tank applications
- Pressure boosting
- Heating pumps
- Dewatering, mining, hot springs
- Industrial applications

Note: For other applications, please contact Well Pumps.

4" WPS®

Pump and motor range

The 4" WPS® pump range consists of six flow models: 1.5, 2.5, 4, 7, 13 and 20m³/h. The pump-end is entirely made out of Stainless Steel DIN 1.4301, AISI 304 or 1.4401, AISI 316. Seals and bearings are standard constructed out of NBR rubber but are also available in Viton® for special applications.

4" WPS® motors are encapsulated, water-filled and all components in contact with water are constructed out of Stainless Steel DIN 1.4301, AISI 304 or DIN 1.4401, AISI 316 and available in single phase from 0,37kW up to 2,2kW and in three phase from 0,37kW up to 7,5kW.

Construction of the pump



Impeller

- 1 6 contact points with the shaft
- 2 6 welding points on each vane
- 3 5 different shapes and 8 flows
- 4 Stainless steel sheet with a minimum thickness of 1mm

Diffuser

- 5 Stainless steel sheet with a minimum thickness of 1mm
- 6 Generously dimensioned intermediate bearing in NBR (or Viton®) at each pump stage
- 7 Neck ring in PTFE

Top Bearing

- 8 Water-lubricated upper bearing in NBR (or Viton®) for each pump

Shaft

- 9 Hexagonal shaft in stainless steel
- 10 Pin to ensure motor power up to 7,5kW
- 11 High-quality coupling made of full stainless steel shaft
- 12 Quenched disc for absorption of axial forces

- 13 Up-trust Washer (patented)

Pipe connection

The 4" WPS® pumps have a Rp1 ½" connection for the models 4" WPS® 1,5 (NE), 4" WPS® 2,5 (NE) and 4" WPS® 4 (NE). The 4" WPS® 7 (NE), 4" WPS® 13 (NE) and 4" WPS® 20 (N) pumps have a Rp 2" outlet. Flange adaptors are available on request.

Pump identification code

Example

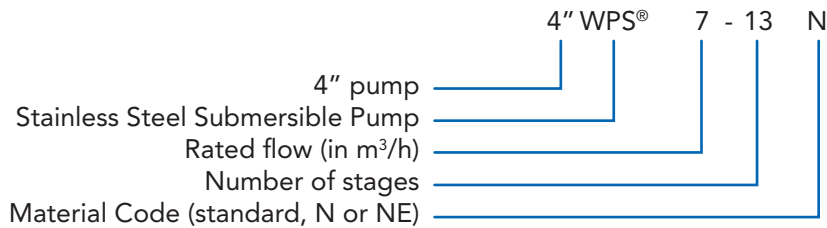

Pumped liquids

4" WPS® pumps are designed for pumping thin, clean, non-aggressive and non-explosive liquids, not containing solid particles.

4" WPS® pumps are suitable for pumping liquids with a content of sand up to 150 g/m³. A higher content of sand will shorten pump lifetime.

The maximum fluid temperature is 35°C. For higher temperatures, please contact Well Pumps.

Operating condition

4" WPS® pumps can be installed in horizontal or vertical position. The maximum pumped liquid temperature is limited to 35°C with a minimum flow over the motor of 8 cm/sec and this to ensure the cooling of the motor. For applications with a higher liquid temperature or lower cooling speeds, please contact Well Pumps S.A.

Curve Conditions

- Curve tolerances according to ISO 9906:2012, class 3B.
- The performance curves show pump performance at actual speed of the standard motor range.
- The measurements were made with airless water at a temperature of 20°C and a kinematic viscosity of 1 mm²/s (1 cSt). For pumping liquids with a higher density than clear water, motors must be used with correspondingly higher outputs.
- Q/H: The curves are inclusive of valve and inlet losses at the actual speed.
- Power curve: P₂ shows pump input power at the actual speed for each individual pump size.
- Efficiency curve: η shows pump efficiency.

Service

The pump and motor are very easy to maintain and repair. The modular pump and motor design facilitates installation and service.

Performance Curves

Performance Curves 4"WPS® 1,5 and 4"WPS® 1,5 N(E)



4"WPS®

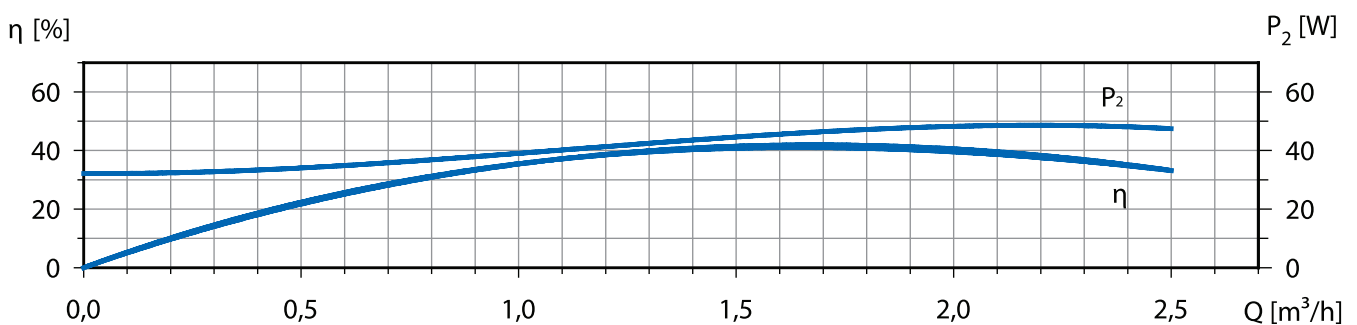
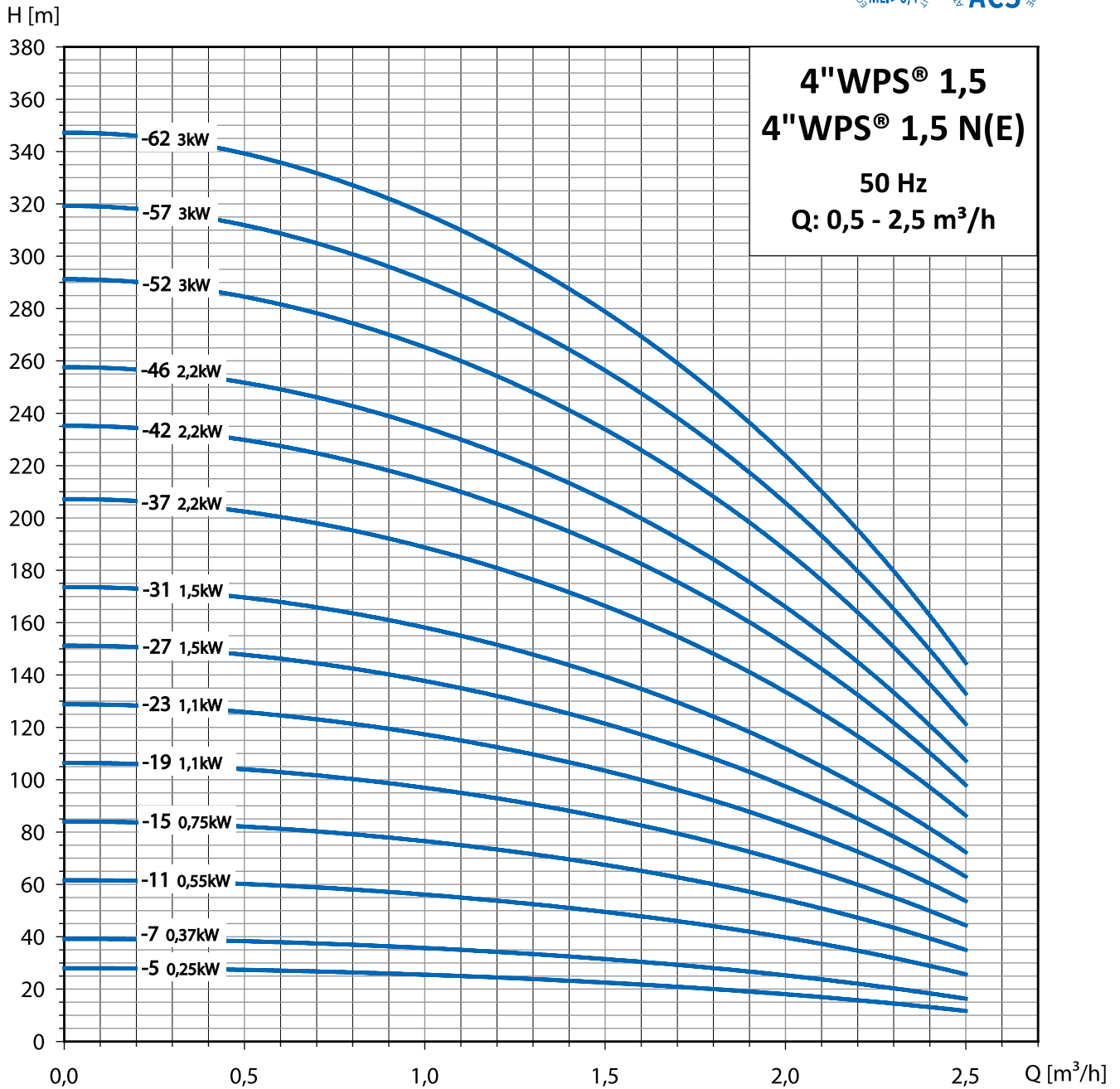

Curves Tolerances according to ISO 9906:2012 Grade 3B

Selection Chart 4"WPS® 1,5 and 4"WPS® 1,5 N(E)

Pump Type	Pump Power P ₂		Flow [m ³ /h]						Full load current	
	[kW]	[HP]	0	0,5	1	1,5	2	2,5	1x230V	3x400V
4"WPS® 1,5-5	0,25	0,33	28	27	26	23	18	12	2,4	0,7
4"WPS® 1,5-7	0,37	0,5	39	38	36	32	25	16	3,3	1,1
4"WPS® 1,5-11	0,55	0,75	62	60	56	50	39	26	4,3	1,6
4"WPS® 1,5-15	0,75	1	84	82	77	68	54	35	5,7	2
4"WPS® 1,5-19	1,1	1,5	106	104	97	86	68	44	8	2,6
4"WPS® 1,5-23	1,1	1,5	129	126	117	104	83	53	8,4	2,8
4"WPS® 1,5-27	1,5	2	151	148	138	122	97	63	9,5	3,4
4"WPS® 1,5-31	1,5	2	174	170	158	140	111	72	10,7	3,9
4"WPS® 1,5-37	2,2	3	207	202	189	167	133	86	12,1	5,1
4"WPS® 1,5-42	2,2	3	235	230	214	189	151	97	14,3	5,3
4"WPS® 1,5-46	2,2	3	258	252	235	207	165	107	14,7	5,5
4"WPS® 1,5-52	3	4	291	284	265	234	187	121	–	6,8
4"WPS® 1,5-57	3	4	319	312	291	257	205	132	–	7,2
4"WPS® 1,5-62	3	4	347	339	316	279	223	144	–	7,5

4"WPS®

Dimensions and Weights 4"WPS® 1,5 and 4"WPS® 1,5 N(E)

Pump Type	Pump Power P ₂		Pump data			Weight [kg]	
	[kW]	[HP]	A [mm]	B [mm]	C [mm]	Pump end	Electropump
4"WPS® 1,5-5	0,25	0,33	301	214	515	3,2	10,4
4"WPS® 1,5-7	0,37	0,5	373	214	587	4,2	11,4
4"WPS® 1,5-11	0,55	0,75	470	228	698	5,5	13,2
4"WPS® 1,5-15	0,75	1	566	248	814	6,9	15,6
4"WPS® 1,5-19	1,1	1,5	663	283	946	8,2	18,4
4"WPS® 1,5-23	1,1	1,5	759	283	1042	9,5	19,7
4"WPS® 1,5-27	1,5	2	856	307	1163	10,9	22,1
4"WPS® 1,5-31	1,5	2	952	307	1259	12,2	23,4
4"WPS® 1,5-37	2,2	3	1097	339	1436	14,2	26,8
4"WPS® 1,5-42	2,2	3	1217	339	1556	15,9	28,5
4"WPS® 1,5-46	2,2	3	1314	339	1653	17,2	29,8
4"WPS® 1,5-52	3	4	1459	394	1853	19,2	34,2
4"WPS® 1,5-57	3	4	1579	394	1973	20,9	35,9
4"WPS® 1,5-62	3	4	1700	394	2094	22,6	37,6

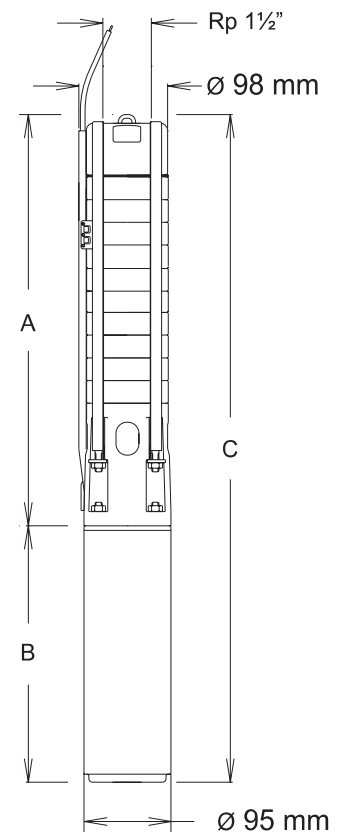

Performance Curves

Performance Curves 4" WPS® 2,5 and 4" WPS® 2,5 N(E)



4" WPS® 2,5

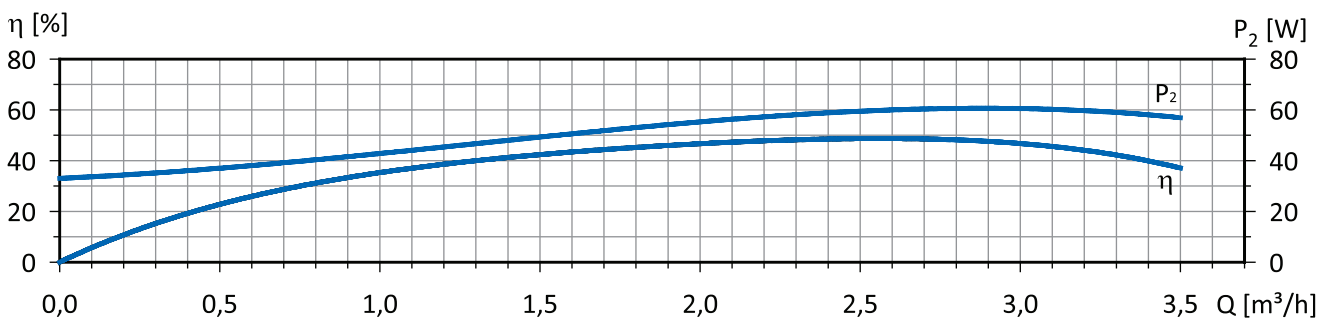
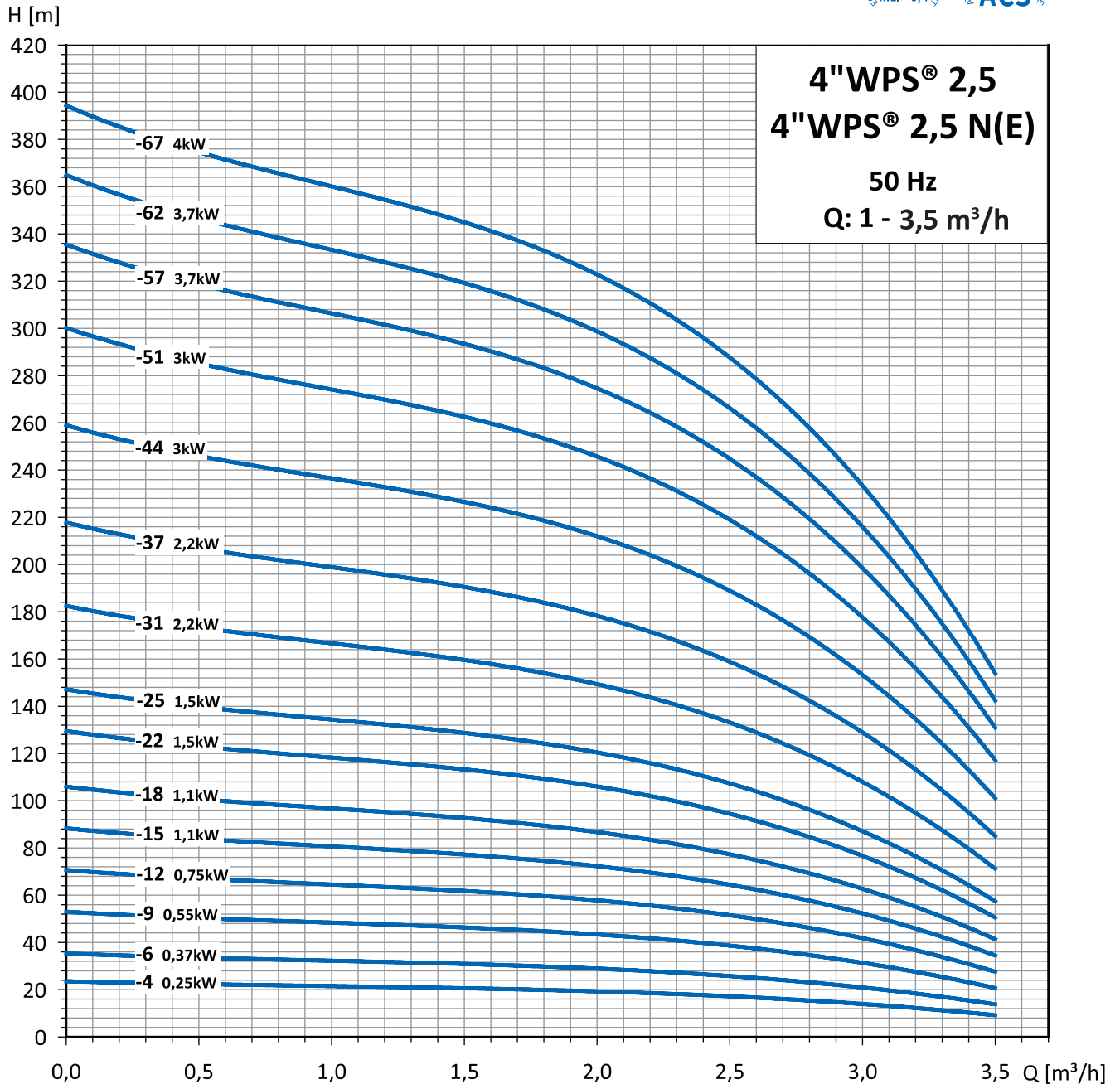

Selection Chart 4"WPS® 2,5 and 4"WPS® 2,5 N(E)

Pump Type	Pump Power P ₂		Flow [m ³ /h]								Full load current	
	[kW]	[HP]	0	0,5	1	1,5	2	2,5	3	3,5	1x230V	3x400V
4"WPS® 2,5-4	0,25	0,33	24	22	22	21	19	17	14	9	2,4	0,7
4"WPS® 2,5-6	0,37	0,5	35	34	32	31	29	26	21	14	3,3	1,1
4"WPS® 2,5-9	0,55	0,75	53	50	49	46	43	39	32	21	4,3	1,6
4"WPS® 2,5-12	0,75	1	71	67	65	62	58	52	42	27	5,7	2
4"WPS® 2,5-15	1,1	1,5	88	84	81	77	72	65	53	34	7,9	2,6
4"WPS® 2,5-18	1,1	1,5	106	101	97	93	86	77	63	41	8,4	2,8
4"WPS® 2,5-22	1,5	2	129	123	119	113	106	95	77	50	9,8	3,6
4"WPS® 2,5-25	1,5	2	147	140	135	129	120	108	88	57	10,7	3,9
4"WPS® 2,5-31	2,2	3	182	173	167	160	149	133	109	71	11,6	5,1
4"WPS® 2,5-37	2,2	3	218	207	200	191	178	159	130	84	12,5	5,5
4"WPS® 2,5-44	3	4	259	246	238	227	211	189	154	100	-	7
4"WPS® 2,5-51	3	4	300	285	275	263	245	219	179	116	-	7,5
4"WPS® 2,5-57	3,7	5	335	319	308	294	274	245	200	130	-	8,4
4"WPS® 2,5-62	3,7	5	365	346	335	319	298	267	218	141	-	9,0
4"WPS® 2,5-67	4	5,5	394	374	362	345	322	289	236	152	-	9,9

4"WPS®

Dimensions and Weights 4"WPS® 2,5 and 4"WPS® 2,5 N(E)

Pump Type	Pump Power P ₂		Pump data			Weight [kg]	
	[kW]	[HP]	A [mm]	B [mm]	C [mm]	Pump end	Electropump
4"WPS® 2,5-4	0,25	0,33	300	214	514	3,1	10,3
4"WPS® 2,5-6	0,37	0,5	349	214	563	3,8	11,0
4"WPS® 2,5-9	0,55	0,75	421	228	649	4,8	12,5
4"WPS® 2,5-12	0,75	1	493	248	741	5,8	14,5
4"WPS® 2,5-15	1,1	1,5	566	283	849	6,8	17,0
4"WPS® 2,5-18	1,1	1,5	638	283	921	7,7	17,9
4"WPS® 2,5-22	1,5	2	735	307	1042	9,1	20,3
4"WPS® 2,5-25	1,5	2	807	307	1114	10,1	21,3
4"WPS® 2,5-31	2,2	3	952	339	1291	12,0	24,6
4"WPS® 2,5-37	2,2	3	1096	339	1435	14,0	26,6
4"WPS® 2,5-44	3	4	1265	401	1666	16,3	31,3
4"WPS® 2,5-51	3	4	1434	401	1835	18,6	33,6
4"WPS® 2,5-57	3,7	5	1579	520	2099	20,6	39,7
4"WPS® 2,5-62	3,7	5	1699	520	2219	22,2	41,3
4"WPS® 2,5-67	4	5,5	1820	543	2363	24,2	44,2

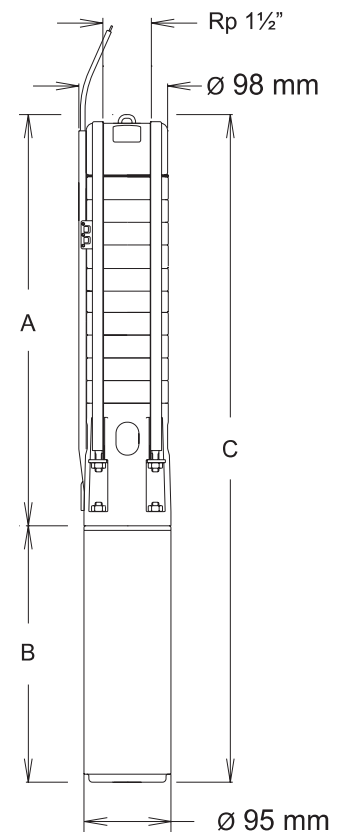

Performance Curves

Performance Curves 4"WPS® 4 and 4"WPS® 4 N(E)



4"WPS® 4

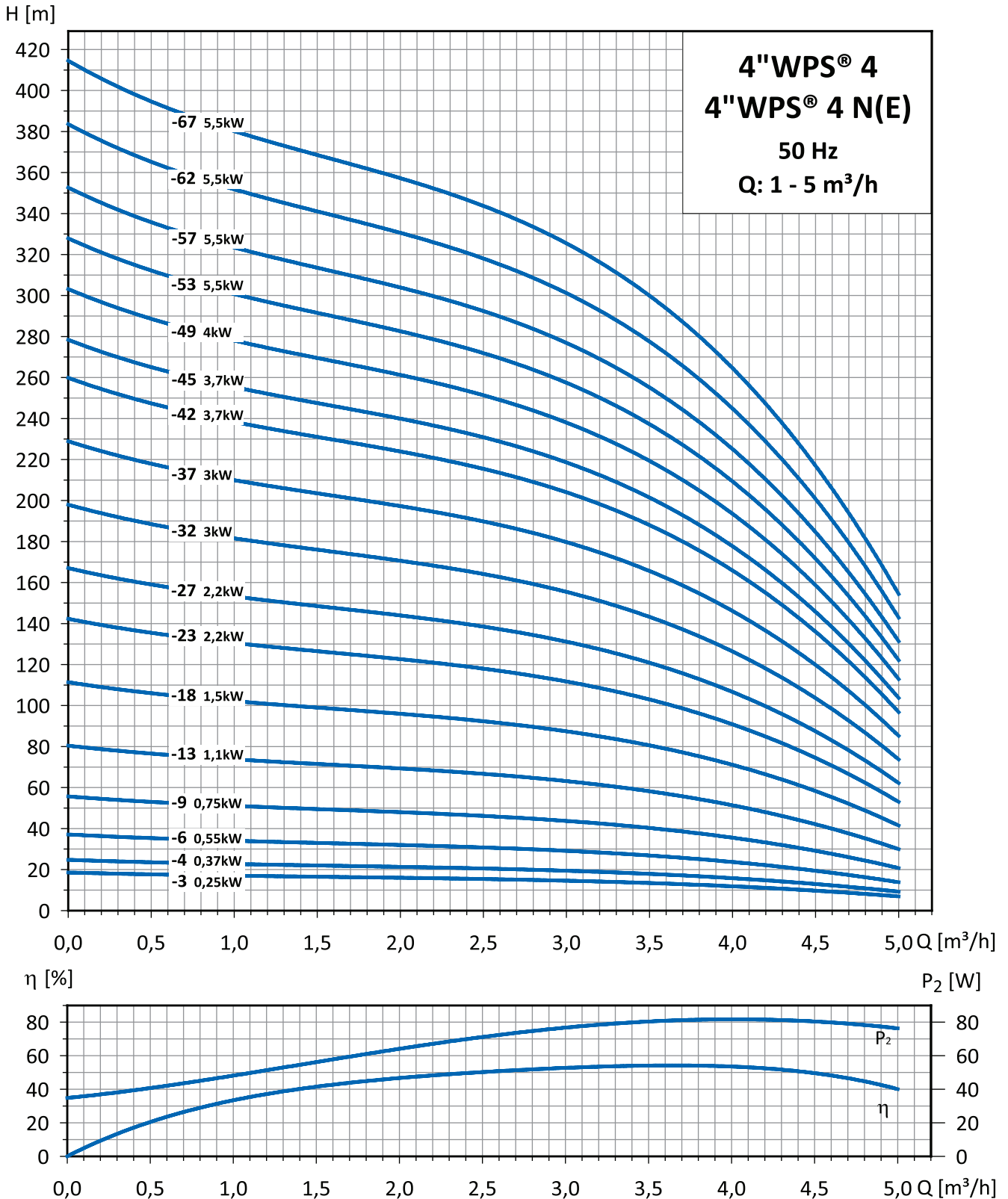

Selection Chart 4"WPS® 4 and 4"WPS® 4 N(E)

Pump Type	Pump Power P ₂		Flow [m ³ /h]									Full load current	
	[kW]	[HP]	0	1	2	2,5	3	3,5	4	4,5	5	1x230V	3x400V
4"WPS® 4-3	0,25	0,33	19	17	16	16	14	13	12	10	7	2,4	0,7
4"WPS® 4-4	0,37	0,5	25	22	21	21	19	18	16	13	9	3,3	1,1
4"WPS® 4-6	0,55	0,75	37	34	32	31	29	26	24	19	14	4,3	1,6
4"WPS® 4-9	0,75	1	56	50	48	47	43	40	36	29	21	5,7	2
4"WPS® 4-13	1,1	1,5	81	73	70	67	63	57	52	42	30	8,4	2,8
4"WPS® 4-18	1,5	2	112	101	96	93	87	79	72	58	41	10,7	3,9
4"WPS® 4-23	2,2	3	143	129	123	119	111	101	92	75	53	12,8	5,2
4"WPS® 4-27	2,2	3	167	151	145	140	130	119	108	87	62	14,7	5,5
4"WPS® 4-32	3	4	198	179	172	166	155	141	128	104	74	-	7
4"WPS® 4-37	3	4	229	207	198	192	179	163	148	120	85	-	7,5
4"WPS® 4-42	3,7	5	260	235	225	218	203	185	168	136	97	-	8,6
4"WPS® 4-45	3,7	5	279	252	241	233	217	198	180	146	104	-	9
4"WPS® 4-49	4	5,5	304	274	263	254	237	216	196	159	113	-	9,9
4"WPS® 4-53	5,5	7,5	329	297	284	275	256	233	212	172	122	-	11,3
4"WPS® 4-57	5,5	7,5	353	319	306	295	275	251	228	185	131	-	11,8
4"WPS® 4-62	5,5	7,5	384	347	332	321	299	273	248	201	143	-	12,2
4"WPS® 4-67	5,5	7,5	415	375	359	347	324	295	268	217	153	-	12,6

4"WPS®

Dimensions and Weights 4"WPS® 4 and 4"WPS® 4 N(E)

Pump Type	Pump Power P ₂		Pump data			Weight [kg]	
	[kW]	[HP]	A [mm]	B [mm]	C [mm]	Pump end	Electropump
4"WPS® 4-3	0,25	0,33	276	214	490	2,8	10,0
4"WPS® 4-4	0,37	0,5	300	214	514	3,1	10,3
4"WPS® 4-6	0,55	0,75	349	228	577	3,8	11,5
4"WPS® 4-9	0,75	1	421	248	669	4,8	13,5
4"WPS® 4-13	1,1	1,5	518	282	800	6,1	16,3
4"WPS® 4-18	1,5	2	638	307	945	7,7	18,9
4"WPS® 4-23	2,2	3	759	339	1098	9,4	22,0
4"WPS® 4-27	2,2	3	855	339	1194	10,7	23,3
4"WPS® 4-32	3	4	976	394	1370	12,4	27,4
4"WPS® 4-37	3	4	1096	394	1490	14,0	29,0
4"WPS® 4-42	3,7	5	1217	520	1737	15,6	34,7
4"WPS® 4-45	3,7	5	1289	520	1809	16,6	35,7
4"WPS® 4-49	4	5,5	1386	543	1929	17,9	37,9
4"WPS® 4-53	5,5	7,5	1482	653	2135	19,3	45,9
4"WPS® 4-57	5,5	7,5	1579	653	2232	20,6	47,2
4"WPS® 4-62	5,5	7,5	1699	653	2352	22,2	48,8
4"WPS® 4-67	5,5	7,5	1820	653	2473	23,9	50,5

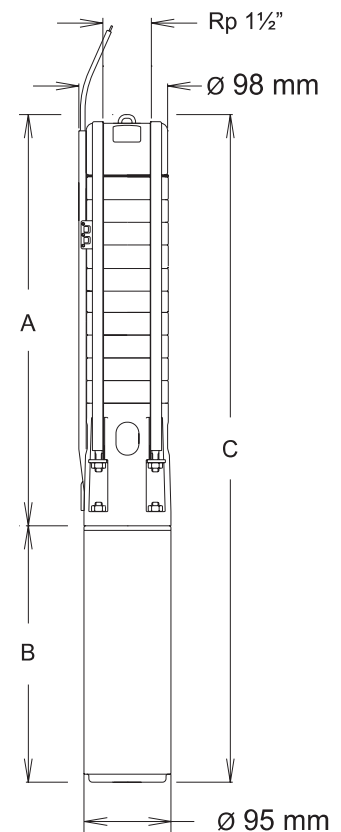

Performance Curves

Performance Curves 4" WPS® 7 and 4" WPS® 7 N(E)



4" WPS® 7

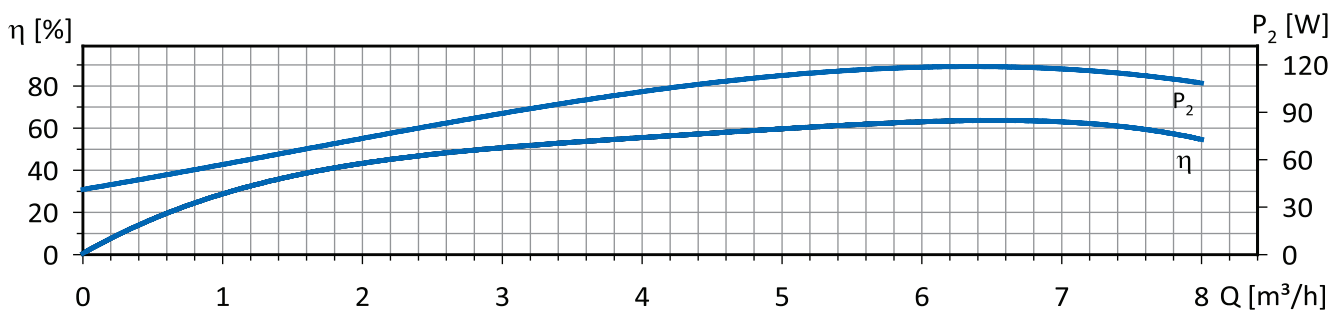
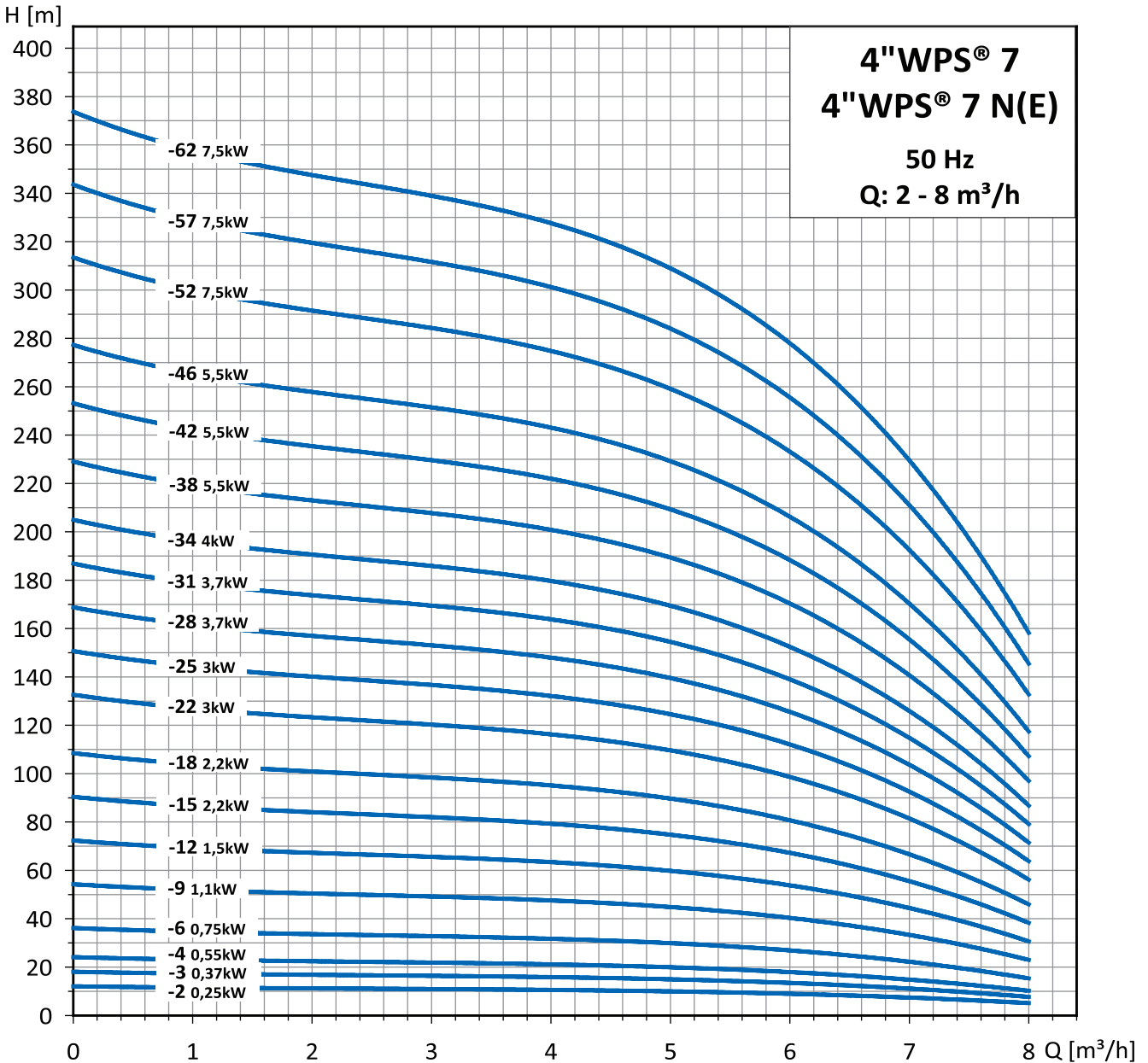

Selection Chart 4"WPS® 7 and 4"WPS® 7 N(E)

Pump Type	Pump Power P ₂		Flow [m ³ /h]									Full load current	
	[kW]	[HP]	0	1	2	3	4	5	6	7	8	1x230V	3x400V
4"WPS® 7-2	0,25	0,33	12	12	11	11	11	10	9	7	5	2,4	0,7
4"WPS® 7-3	0,37	0,5	18	17	17	16	16	15	14	11	8	3,3	1,1
4"WPS® 7-4	0,55	0,75	24	23	22	22	21	20	18	15	10	4,3	1,6
4"WPS® 7-6	0,75	1	36	35	34	33	32	30	27	22	16	5,7	2,0
4"WPS® 7-9	1,1	1,5	54	52	50	49	48	45	41	33	23	8,4	2,8
4"WPS® 7-12	1,5	2	72	70	67	65	64	60	54	44	31	10,7	3,9
4"WPS® 7-15	2,2	3	90	87	84	82	80	75	68	56	39	13,1	5,1
4"WPS® 7-18	2,2	3	108	105	101	98	95	90	81	67	47	14,7	5,5
4"WPS® 7-22	3	4	132	128	123	120	117	110	99	81	57	-	6,6
4"WPS® 7-25	3	4	150	145	140	136	133	126	113	93	65	-	7,5
4"WPS® 7-28	3,7	5	168	163	157	152	148	141	126	104	73	-	8,3
4"WPS® 7-31	3,7	5	186	180	174	169	164	156	140	115	81	-	9,0
4"WPS® 7-34	4	5,5	204	198	190	185	180	171	153	126	88	-	9,9
4"WPS® 7-38	5,5	7,5	228	221	213	207	201	191	171	141	99	-	11,5
4"WPS® 7-42	5,5	7,5	252	244	235	228	223	211	189	155	109	-	12,1
4"WPS® 7-46	5,5	7,5	276	267	258	250	244	231	207	170	120	-	12,6
4"WPS® 7-52	7,5	10	313	302	291	283	276	261	234	192	135	-	15,8
4"WPS® 7-57	7,5	10	343	331	319	310	302	286	257	211	148	-	16,2
4"WPS® 7-62	7,5	10	373	360	347	337	329	311	279	229	161	-	17,1

4"WPS®

Dimensions and Weights 4"WPS® 7 and 4"WPS® 7 N(E)

Pump Type	Pump Power P ₂		Pump data			Weight [kg]	
	[kW]	[HP]	A [mm]	B [mm]	C [mm]	Pump end	Electropump
4"WPS® 7-2	0,25	0,33	252	214	466	2,5	9,7
4"WPS® 7-3	0,37	0,5	276	214	490	2,9	10,1
4"WPS® 7-4	0,55	0,75	300	228	528	3,2	10,9
4"WPS® 7-6	0,75	1	349	248	597	3,9	12,6
4"WPS® 7-9	1,1	1,5	421	282	703	4,9	15,1
4"WPS® 7-12	1,5	2	493	307	800	6,0	17,2
4"WPS® 7-15	2,2	3	566	339	905	7,0	19,6
4"WPS® 7-18	2,2	3	638	339	977	8,0	20,6
4"WPS® 7-22	3	4	735	394	1129	9,4	29,4
4"WPS® 7-25	3	4	807	394	1201	10,5	30,5
4"WPS® 7-28	3,7	5	879	250	1399	11,5	30,6
4"WPS® 7-31	3,7	5	952	520	1472	12,5	31,6
4"WPS® 7-34	4	5,5	1024	543	1567	13,6	33,6
4"WPS® 7-38	5,5	7,5	1121	653	1774	14,9	41,5
4"WPS® 7-42	5,5	7,5	1217	653	1870	16,3	42,9
4"WPS® 7-46	5,5	7,5	1314	653	1967	17,7	44,3
4"WPS® 7-52	7,5	10	1458	731	2189	19,8	50,4
4"WPS® 7-57	7,5	10	1579	731	2340	21,5	52,1
4"WPS® 7-62	7,5	10	1699	731	2430	23,2	53,8

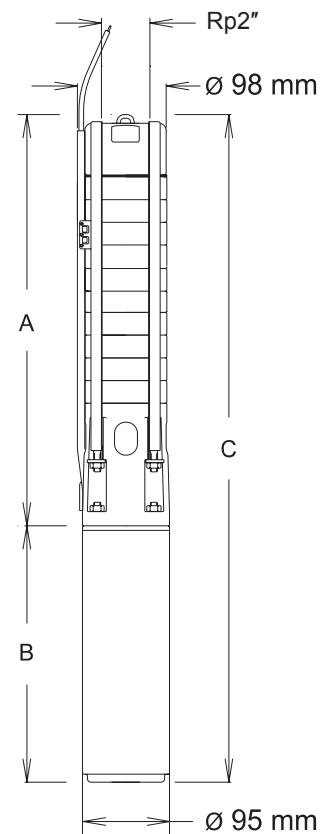

Performance Curves

Performance Curves 4"WPS® 13 and 4"WPS® 13 N(E)



4"WPS®-CP

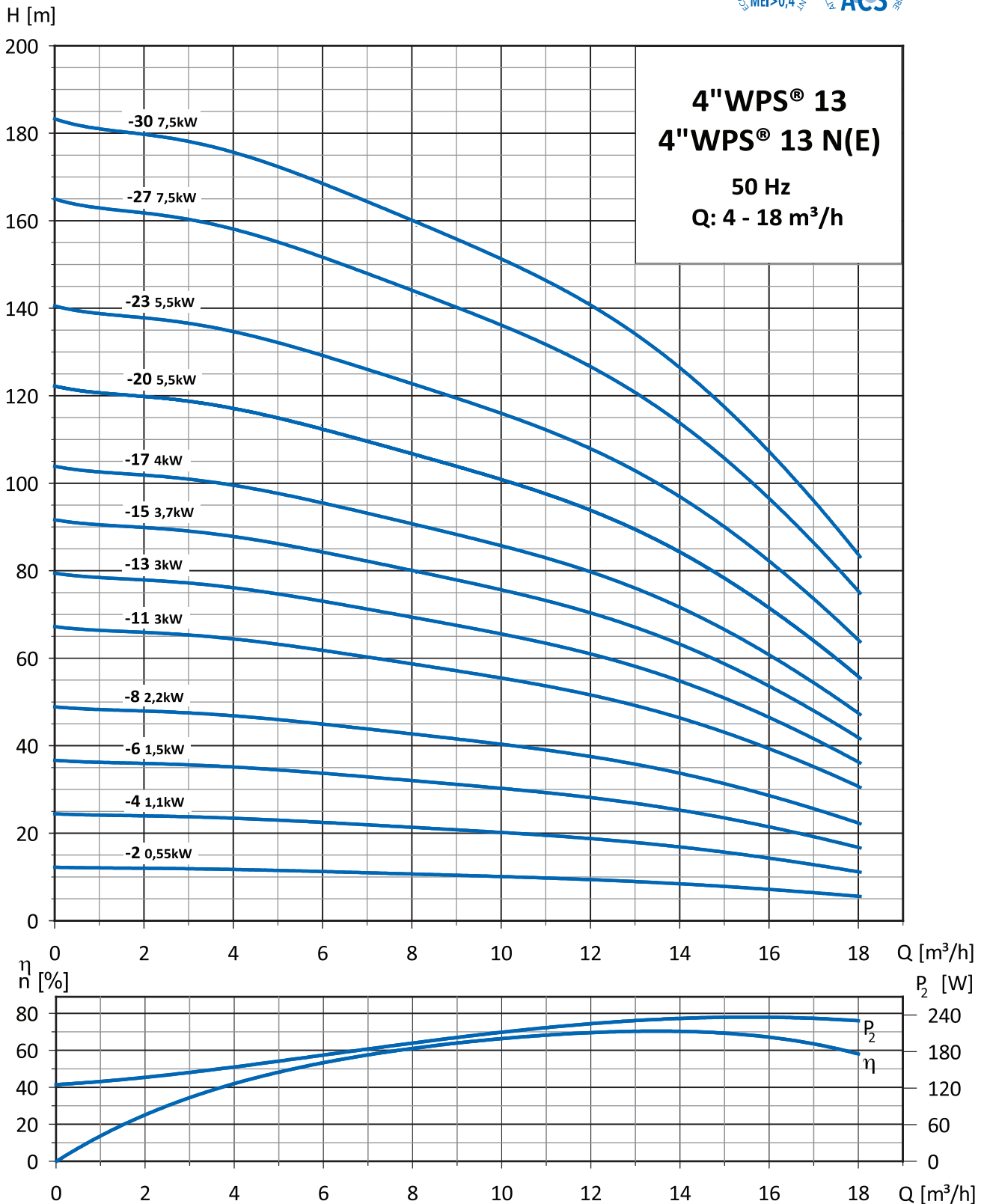

Selection Chart 4"WPS® 13 and 4"WPS® 13 N(E)

Pump Type	Pump Power P ₂		Flow [m ³ /h]									Full load current	
	[kW]	[HP]	0	3	6	9	10	12	14	16	18	1x230V	3x400V
4"WPS® 13-2	0,55	0,75	12	12	11	11	10	9	8	7	6	4,3	1,6
4"WPS® 13-4	1,10	1,50	24	24	23	21	20	19	17	14	11	8,4	2,8
4"WPS® 13-6	1,50	2,00	37	36	34	31	30	28	25	21	17	10,7	3,9
4"WPS® 13-8	2,20	3,00	48	47	45	42	40	38	33	29	22	14,7	5,5
4"WPS® 13-11	3,00	4,00	67	65	62	57	55	52	46	39	31	-	7,0
4"WPS® 13-13	3,00	4,00	79	77	74	67	65	61	54	46	36	-	7,5
4"WPS® 13-15	3,70	5,00	91	89	85	79	76	71	63	53	42	-	9,0
4"WPS® 13-17	4,00	5,50	104	101	96	88	86	80	71	61	47	-	9,9
4"WPS® 13-20	5,50	7,50	122	118	113	103	101	94	84	71	55	-	12,0
4"WPS® 13-23	5,50	7,50	141	136	130	118	116	109	96	82	64	-	12,6
4"WPS® 13-27	7,50	10,00	165	160	153	140	136	127	113	96	75	-	16,0
4"WPS® 13-30	7,50	10,00	183	177	170	155	151	142	126	107	83	-	17,1

4"WPS®

Dimensions and Weights 4"WPS® 13 and 4"WPS® 13 N(E)

Pump Type	Pump Power P ₂		Pump data			Weight [kg]	
	[kW]	[HP]	A [mm]	B [mm]	C [mm]	Pump end	Electropump
4"WPS® 13-2	0,55	0,75	341	226	567	5,4	13,1
4"WPS® 13-4	1,10	1,50	491	282	773	7,3	17,5
4"WPS® 13-6	1,50	2,00	641	307	948	9,3	20,5
4"WPS® 13-8	2,20	3,00	791	339	1130	11,1	23,7
4"WPS® 13-11	3,00	4,00	1016	394	1410	13,9	28,9
4"WPS® 13-13	3,00	4,00	1166	394	1560	15,9	30,9
4"WPS® 13-15	3,70	5,00	1316	520	1836	17,7	36,8
4"WPS® 13-17	4,00	5,50	1466	543	2009	19,4	39,4
4"WPS® 13-20	5,50	7,50	1691	653	2344	22,5	49,1
4"WPS® 13-23	5,50	7,50	1916	653	2569	25,3	51,8
4"WPS® 13-27	7,50	10,00	2216	731	2947	29,1	59,7
4"WPS® 13-30	7,50	10,00	2441	731	3172	32,0	62,6

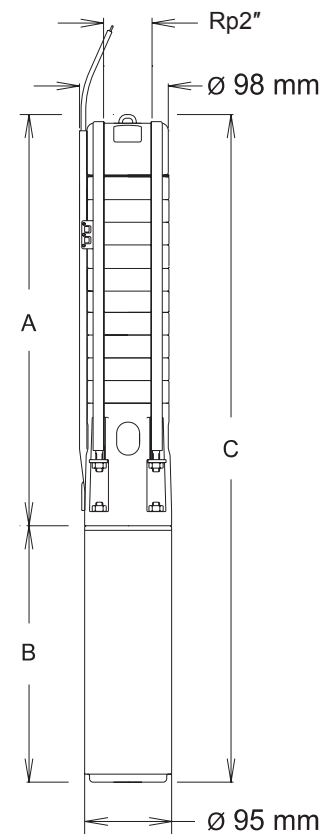

Performance Curves

Performance Curves 4" WPS® 20 and 4" WPS® 20 N



4" WPS® P

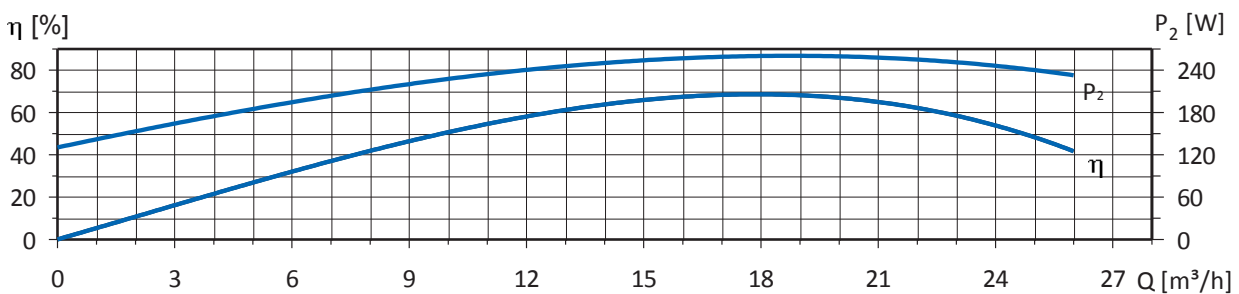
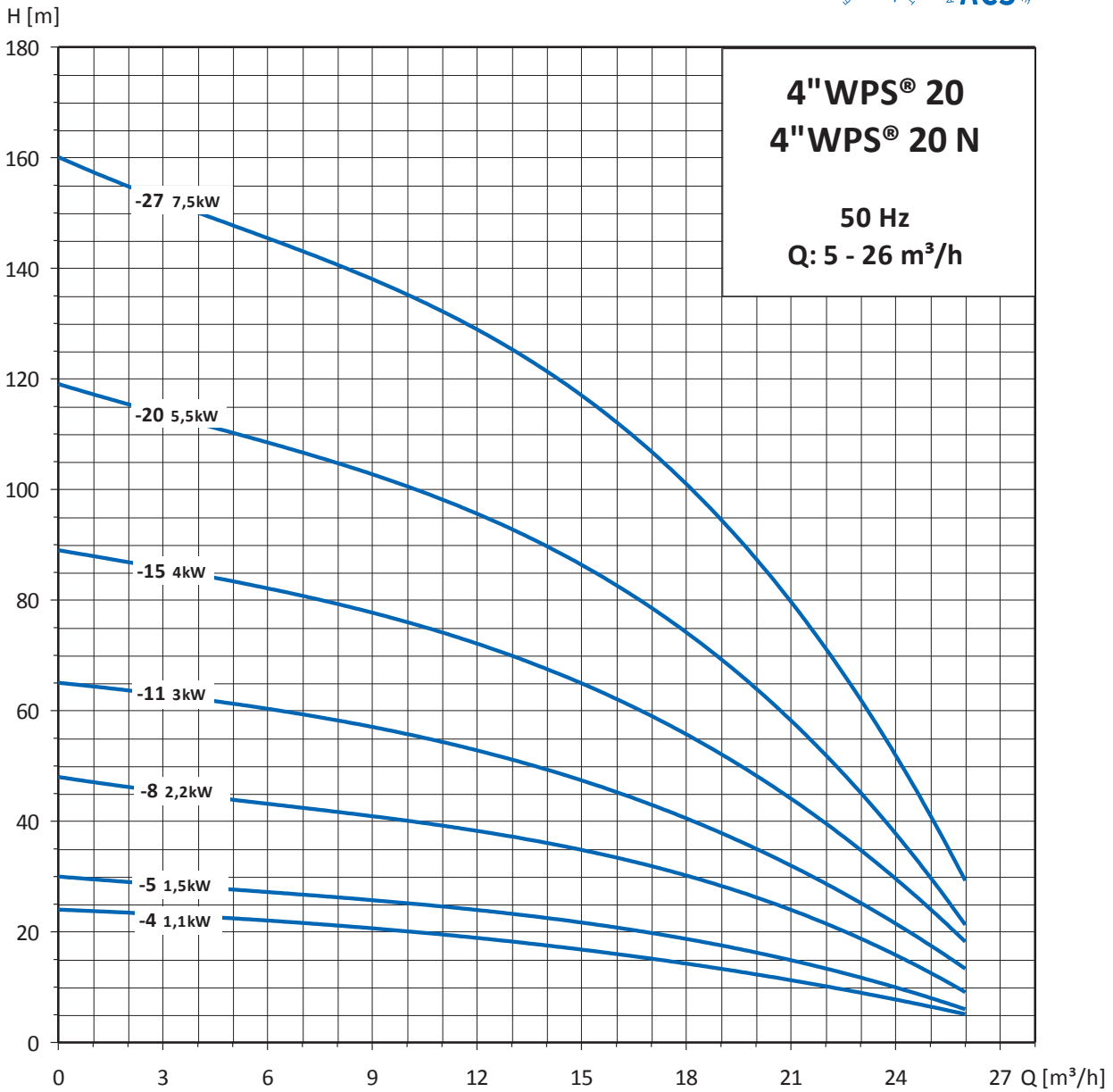

Selection Chart 4" WPS® 20 and 4" WPS® 20 N

Pump Type	Pump Power P ₂		Flow [m ³ /h]						Full load current	
	[kW]	[HP]	0	10	15	20	24	26	1x230V	3x400V
4"WPS® 20-4	1,1	1,5	24	20	17	12	8	5	7,8	3,0
4"WPS® 20-5	1,5	2,0	30	25	22	16	10	6	10,5	4,0
4"WPS® 20-8	2,2	3,0	48	40	35	26	16	9	15,0	5,6
4"WPS® 20-11	3,0	4,0	65	56	47	35	22	13	-	7,5
4"WPS® 20-15	4,0	5,5	89	76	65	48	30	18	-	10,6
4"WPS® 20-20	5,5	7,5	119	101	86	63	40	20	-	13,6
4"WPS® 20-27	7,5	10,0	160	136	116	87	54	28	-	18,3

Dimensions and Weights 4" WPS® 20 and 4" WPS® 20 N

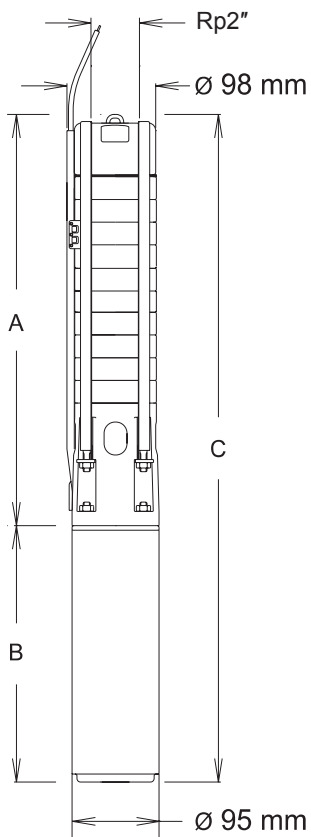

Pump Type	Pump Power P ₂		A [mm]	B [mm]	C [mm]	Weight [kg]	
	[kW]	[HP]				Pump End	Electropump
4"WPS® 20-4	1,1	1,5	445	295	740	8,0	17,9
4"WPS® 20-5	1,5	2,0	518	340	858	9,0	21,4
4"WPS® 20-8	2,2	3,0	737	375	1112	13,0	27,2
4"WPS® 20-11	3,0	4,0	956	480	1436	17,0	35,3
4"WPS® 20-15	4,0	5,5	1248	55	1803	23,0	46,4
4"WPS® 20-20	5,5	7,5	1613	675	2288	30,0	60,4
4"WPS® 20-27	7,5	10,0	2124	765	2889	40,0	73,8

Technical Data

Material specification

4" WPS® P

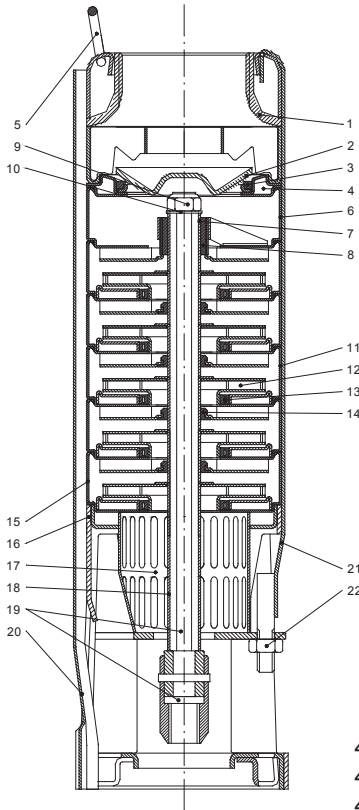

4" WPS® 1,5
4" WPS® 2,5
4" WPS® 4
4" WPS® 7

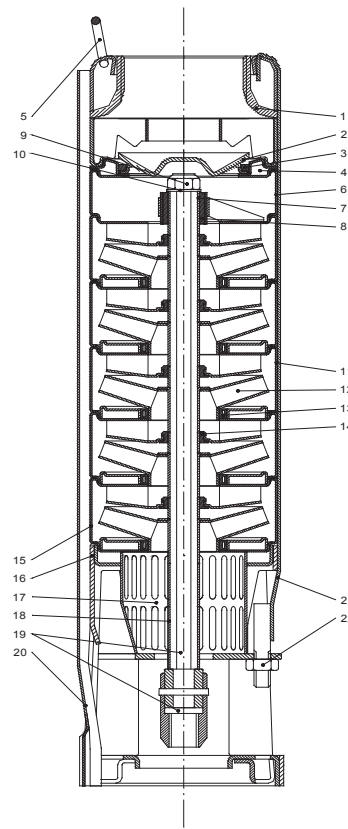

4" WPS® 13
4" WPS® 20

Pos.	Component	Material	4" WPS® Material Code	4" WPS®N Material Code	4" WPS®NE Material code
1	Discharge Chamber	Stainless steel	AISI 304 - 1.4301	AISI 316 - 1.4401	AISI 316 - 1.4401
2	Valve Cone	Stainless steel	AISI 304 - 1.4301	AISI 316 - 1.4401	AISI 316 - 1.4401
3	Valve Seat	Stainless steel/Rubber	AISI 304 - 1.4301/NBR	AISI 316 - 1.4401/NBR	AISI 316 - 1.4401/FKM
4	Retainer for Valve Seat	Stainless steel	AISI 304 - 1.4301	AISI 316 - 1.4401	AISI 316 - 1.4401
5	Hook	Stainless steel	AISI 304 - 1.4301	AISI 316 - 1.4401	AISI 316 - 1.4401
6	Top Diffuser	Stainless steel	AISI 304 - 1.4301	AISI 316 - 1.4401	AISI 316 - 1.4401
7	Top Spacer	Stainless steel	AISI 304 - 1.4301	AISI 316 - 1.4401	AISI 316 - 1.4401
8	Top Bearing	Stainless steel/Rubber	AISI 304 - 1.4301/NBR	AISI 316 - 1.4401/NBR	AISI 316 - 1.4401/FKM
9	Nut M8	Stainless steel	AISI 304 - 1.4301	AISI 316 - 1.4401	AISI 316 - 1.4401
10	Washer	Stainless steel	AISI 304 - 1.4301	AISI 316 - 1.4401	AISI 316 - 1.4401
11	Diffuser	Stainless steel	AISI 304 - 1.4301	AISI 316 - 1.4401	AISI 316 - 1.4401
12	Impeller	Stainless steel	AISI 304 - 1.4301	AISI 316 - 1.4401	AISI 316 - 1.4401
13	Neck ring	Teflon	PTFE	PTFE	PTFE
14	Indermediate Bearing	Rubber	NBR	NBR	FKM
15	Bottom Diffuser	Stainless steel	AISI 304 - 1.4301	AISI 316 - 1.4401	AISI 316 - 1.4401
16	Suction Interconnector	Stainless steel	AISI 304 - 1.4301	AISI 316 - 1.4401	AISI 316 - 1.4401
17	Strainer	Stainless steel	AISI 304 - 1.4301	AISI 316 - 1.4401	AISI 316 - 1.4401
18	Bottom Spacer	Stainless steel	AISI 304 - 1.4301	AISI 316 - 1.4401	AISI 316 - 1.4401
19	Shaft with NEMA coupling	Stainless steel	AISI 304 - 1.4301	AISI 904L - 1.4539	AISI 904L - 1.4539
20	Cable Guards	Stainless steel	AISI 304 - 1.4301	AISI 316 - 1.4401	AISI 316 - 1.4401
21	Strap	Stainless steel	AISI 304 - 1.4301	AISI 316 - 1.4401	AISI 316 - 1.4401
22	Nut M8-M10	Stainless steel	AISI 304 - 1.4301	AISI 316 - 1.4401	AISI 316 - 1.4401
23	Up-trust Washer	Teflon	PTFE	PTFE	PTFE

4"WPS® P pumps are constructed out of stainless steel AISI304 and are equipped with Noryl® floating impellers and polycarbonate diffusor parts.

Pumps are suitable for both continuous and intermittent operation for a variety of applications:

- Domestic and general water supply
- Irrigation
- Tank applications
- Pressure boosting

Note: for other applications, please contact Well Pumps.



4"WPS®

4"WPS® P

4"WPS® P pumps offer the following features:

- Discharge chamber and Suction Interconnector are precision casted in stainless steel AISI 304.
- Motor adaptor following NEMA standard.
- Impellers are floating type and made out of Noryl®. This in combination with glass fiber polycarbonate diffusors parts leads to a strong pump with an good resistance against abrasion. Maximum sand content 150 g/m³
- The bowl part of the diffusor is produced out of stainless steel AISI 304.
- Shaft and coupling are constructed out of stainless steel AISI 304.
- Stainless steel AISI 304 non-return valve cone.
- Top Bearing is produced out of Polyacetal with strong resistance to wear and abrasion.
- Strong Pump Sleeve of 1.5mm thick out of stainless steel AISI 304.
- Strainer produced of stamped AISI304 stainless steel.
- Suitable for drinking water applications: ACS and FDA-certified.

Pump and motor range

4"WPS® P pump range consists of nine flow models: 1, 2, 3, 4, 6, 8, 10, 12 and 16 m³/h. Pumps are mounted on 4"WPS® encapsulated water-filled submersible motors with all parts in contact with water made out of stainless steel AISI 304. Power range from 0,37 up to 2,2 kW in single phase and up to 7,5 kW in three phase supply.

Pipe connection

4"WPS® P pumps with flow of 1, 2 and 3 m³/h have a Rp 1 ¼" outlet. The 4"WPS® 4 P pump has an outlet of Rp 1 ½" and pumps with flow range of 6m³/h and higher has a Rp 2" outlet.

Pump identification code

Example

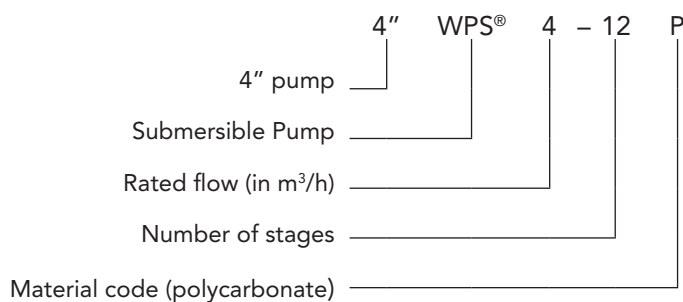

Curve conditions

- Curve tolerances according to ISO 9906:2012, class 3B.
- The performance curves show pump performance at actual speed of the standard motor range.
- The measurements were made with airless water at a temperature of 20°C and a kinematic viscosity of 1 mm²/s. For pumping liquids with a higher density than clear water, motors must be used with correspondingly higher outputs.
- Q/H: the curves are inclusive a valve and inlet losses at actual speed.
- Power curve: P₂ shows pump input power at the actual speed for each individual pump size.
- Efficiency curve: η shows pump efficiency.

Material specification

4" WPS® P

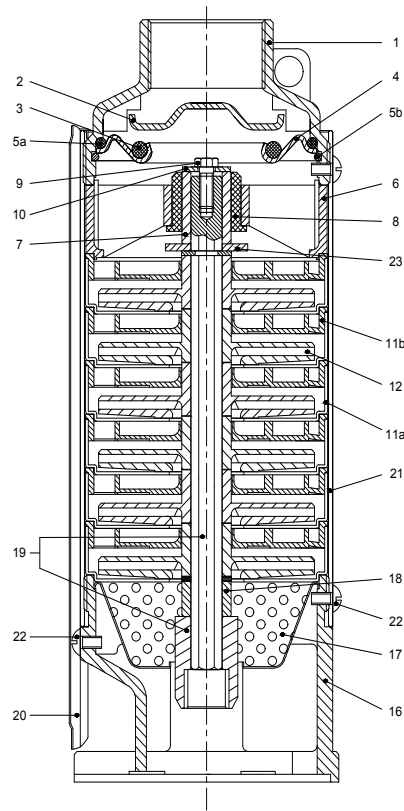

Pos.	Component	Material	Material Code
1	Discharge Chamber	Stainless steel	AISI 304 - 1.4301
2	Valve Cone	Stainless steel	AISI 304 - 1.4301
3	Valve Seat	Rubber	NBR
4	Retainer for Valve Seat	Stainless steel	AISI 304 - 1.4301
5a	O-ring for Retainer (Top)	Rubber	NBR
5b	O-ring for Retainer (Bottom)	Rubber	NBR
6	Top Diffusor	Polycarbonate	PC
7	Top Spacer	Stainless steel	AISI 304 - 1.4301
8	Top Bearing	Polyacetal	POM
9	Fixing Bolt	Stainless steel	AISI 304 - 1.4301
10	Washer	Stainless steel	AISI 304 - 1.4301
11a	Diffusor Housing	Stainless steel	AISI 304 - 1.4301
11b	Diffusor	Polycarbonate	AISI 304 - 1.4301
12	Impeller	Noryl	Noryl
16	Suction Interconnector	Stainless steel	AISI 304 - 1.4301
17	Strainer	Stainless steel	AISI 304 - 1.4301
18	Bottom Spacer	Polycarbonate	PC
19	Shaft with NEMA Coupling	Stainless steel	AISI 304 - 1.4301
20	Cable Guard	Stainless steel	AISI 304 - 1.4301
21	Pump Sleeve	Stainless steel	AISI 304 - 1.4301
22	Fixing Bolt	Stainless steel	AISI 304 - 1.4301
23	Uptrust Washer	Stainless steel	AISI 304 - 1.4301

Performance Curves 4"WPS® 1 P

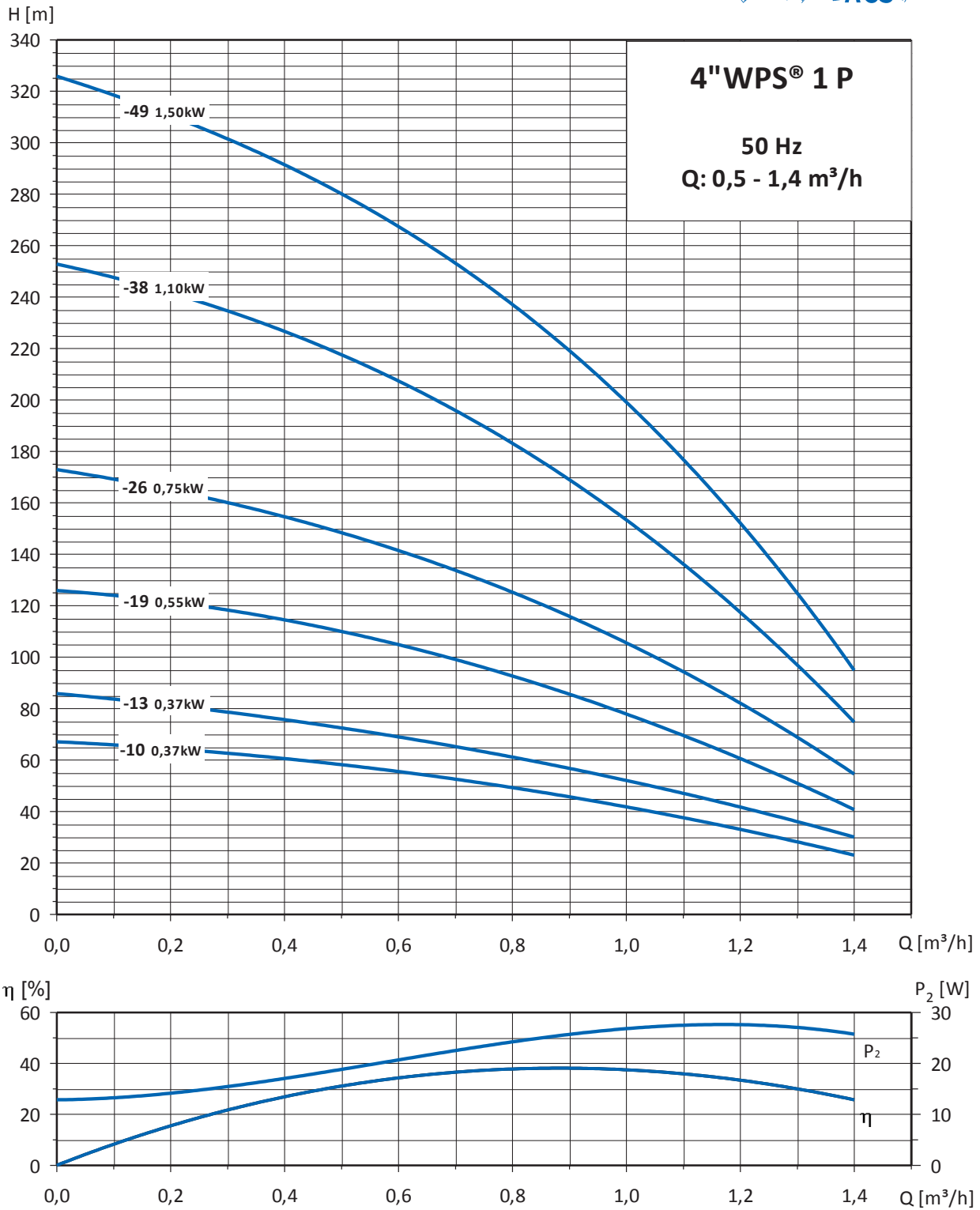

4"WPS® P

Technical Data

Selection Chart 4" WPS® 1 P

4" WPS® 1 P

Pump Type	Pump Power P ₂		Flow [m³/h]						Full load current	
	[kW]	[HP]	0	0,3	0,6	0,9	1,2	1,5	1x230V	3x400V
4" WPS® 1-10 P	0,37	0,50	67	63	55	46	33	18	3,4	1,3
4" WPS® 1-13 P	0,37	0,50	86	78	70	56	42	23	3,4	1,3
4" WPS® 1-19 P	0,55	0,75	126	118	105	86	60	30	4,4	1,7
4" WPS® 1-26 P	0,75	1,00	173	160	141	117	81	39	6,0	2,2
4" WPS® 1-38 P	1,10	1,50	253	234	208	169	117	52	7,8	3,0
4" WPS® 1-49 P	1,50	2,00	326	301	268	219	151	67	10,5	4,0

Dimensions and Weights 4" WPS® 1 P

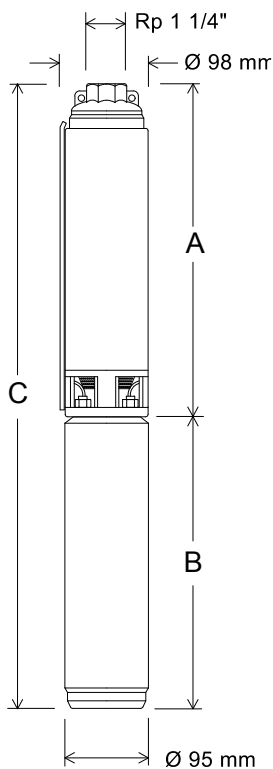

Pump Type	Pump Power P ₂		A [mm]	B [mm]	C [mm]	Weight [kg]	
	[kW]	[HP]				Pump End	Electropump
4" WPS® 1-10 P	0,37	0,50	324	235	559	3,3	9,1
4" WPS® 1-13 P	0,37	0,50	377	235	612	3,7	9,5
4" WPS® 1-19 P	0,55	0,75	481	250	731	4,7	11,7
4" WPS® 1-26 P	0,75	1,00	642	264	907	5,8	14,1
4" WPS® 1-38 P	1,10	1,50	864	295	1 159	9,2	20,1
4" WPS® 1-49 P	1,50	2,00	1105	340	1445	12,5	23,4

Performance Curves 4"WPS® 2 P

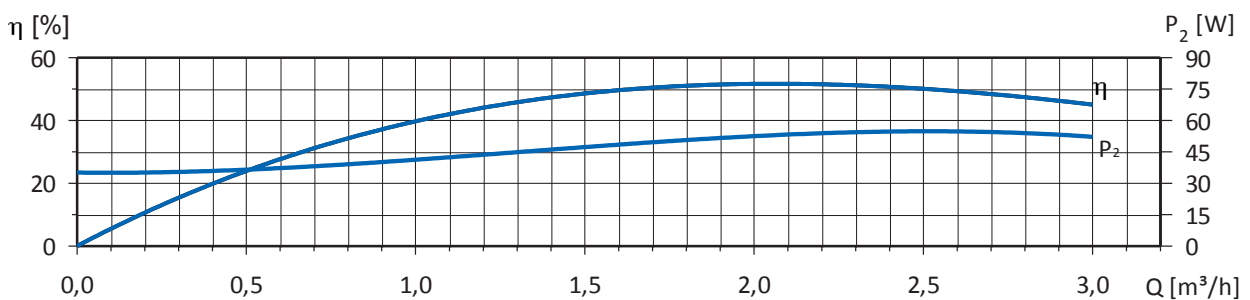
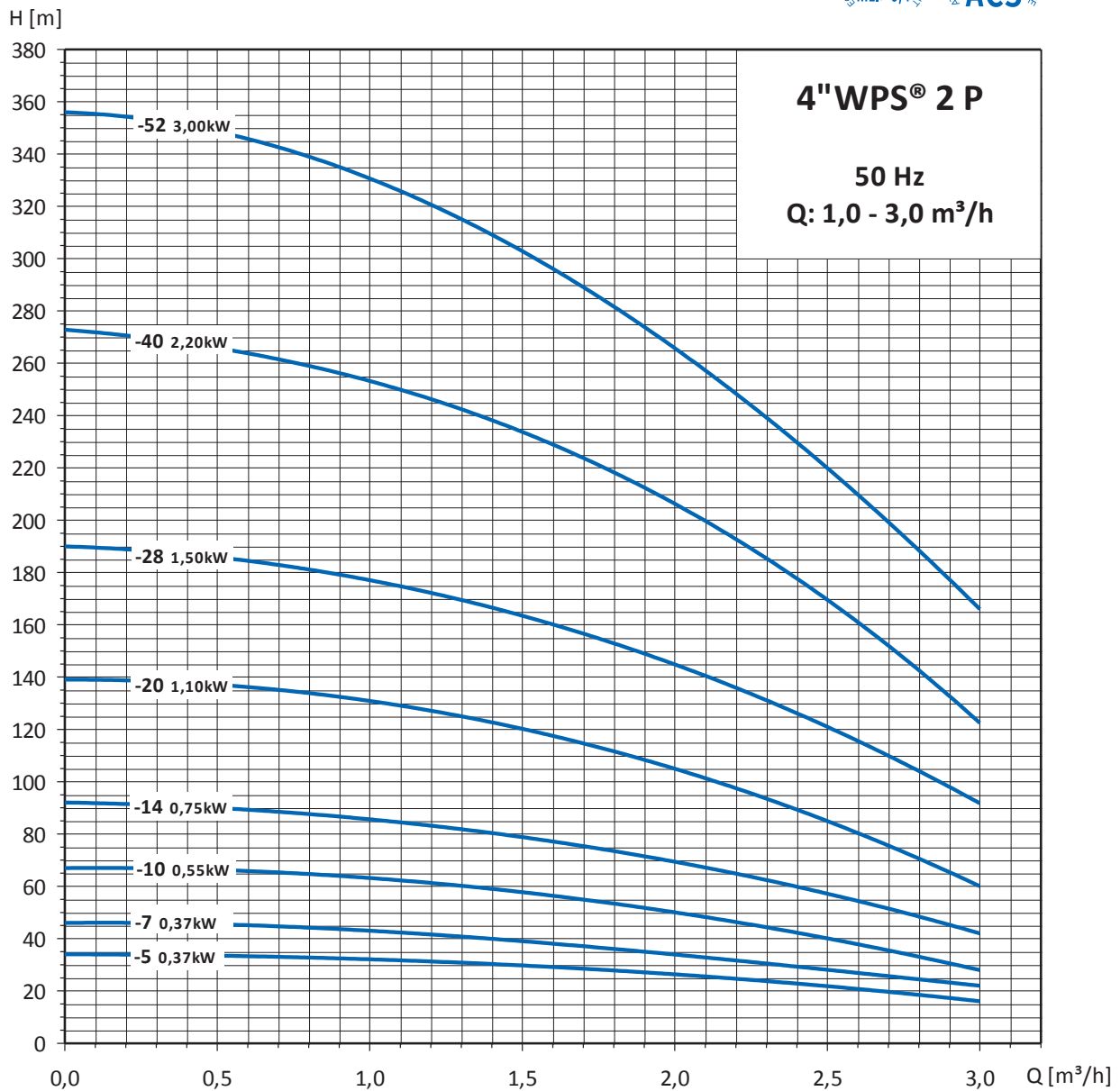

4"WPS® P

Technical Data

Selection Chart 4" WPS® 2 P

4" WPS® 2 P

Pump Type	Pump Power P ₂		Flow [m ³ /h]						Full load current	
	[kW]	[HP]	0	1,0	1,5	2,0	2,5	3,0	1x230V	3x400V
4" WPS® 2-5 P	0,37	0,50	34	33	30	26	22	16	3,4	1,3
4" WPS® 2-7 P	0,37	0,50	46	43	39	34	28	22	3,4	1,3
4" WPS® 2-10 P	0,55	0,75	67	63	58	50	40	28	4,4	1,7
4" WPS® 2-14 P	0,75	1,00	92	86	78	70	57	42	6,0	2,2
4" WPS® 2-20 P	1,10	1,50	139	131	120	105	85	60	7,8	3,0
4" WPS® 2-28 P	2,20	3,00	190	177	163	146	120	92	10,5	5,6
4" WPS® 2-40 P	2,20	3,00	273	252	235	207	168	123	15,0	5,6
4" WPS® 2-52 P	3,00	4,00	356	330	304	265	220	166	-	7,5

Dimensions and Weights 4" WPS® 2 P

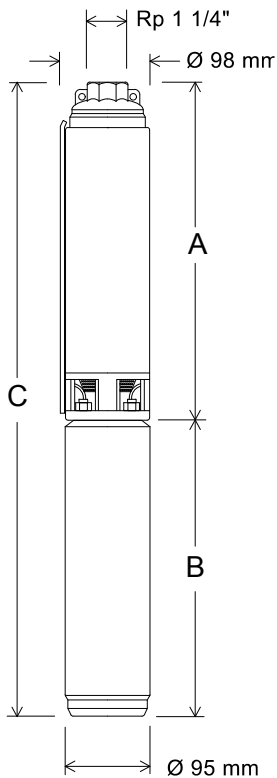

Pump Type	Pump Power P ₂		A [mm]	B [mm]	C [mm]	Weight [kg]	
	[kW]	[HP]				Pump End	Electropump
4" WPS® 2-5 P	0,37	0,50	236	235	471	2,5	8,3
4" WPS® 2-7 P	0,37	0,50	271	235	506	2,8	8,6
4" WPS® 2-10 P	0,55	0,75	324	250	574	3,3	10,3
4" WPS® 2-14 P	0,75	1,00	394	265	659	3,9	12,2
4" WPS® 2-20 P	1,10	1,50	499	295	794	4,9	15,8
4" WPS® 2-28 P	2,20	3,00	679	375	1054	7,1	21,3
4" WPS® 2-40 P	2,20	3,00	950	375	1325	10,5	24,7
4" WPS® 2-52 P	3,00	4,00	1235	480	1715	13,5	31,8

Performance Curves 4"WPS® 3 P

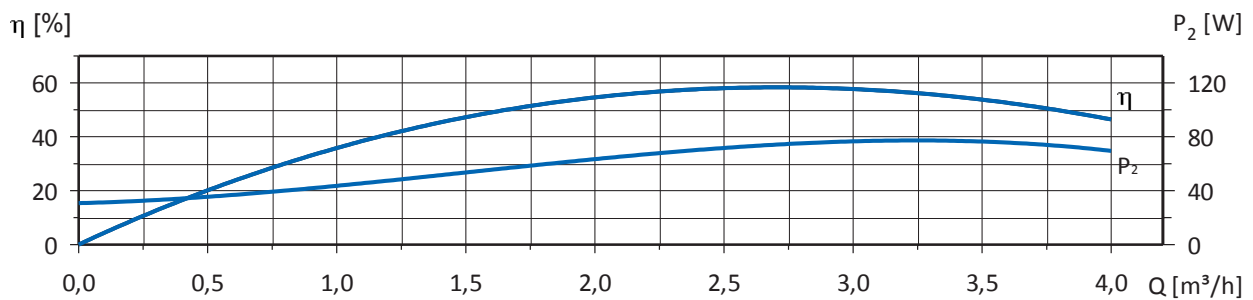
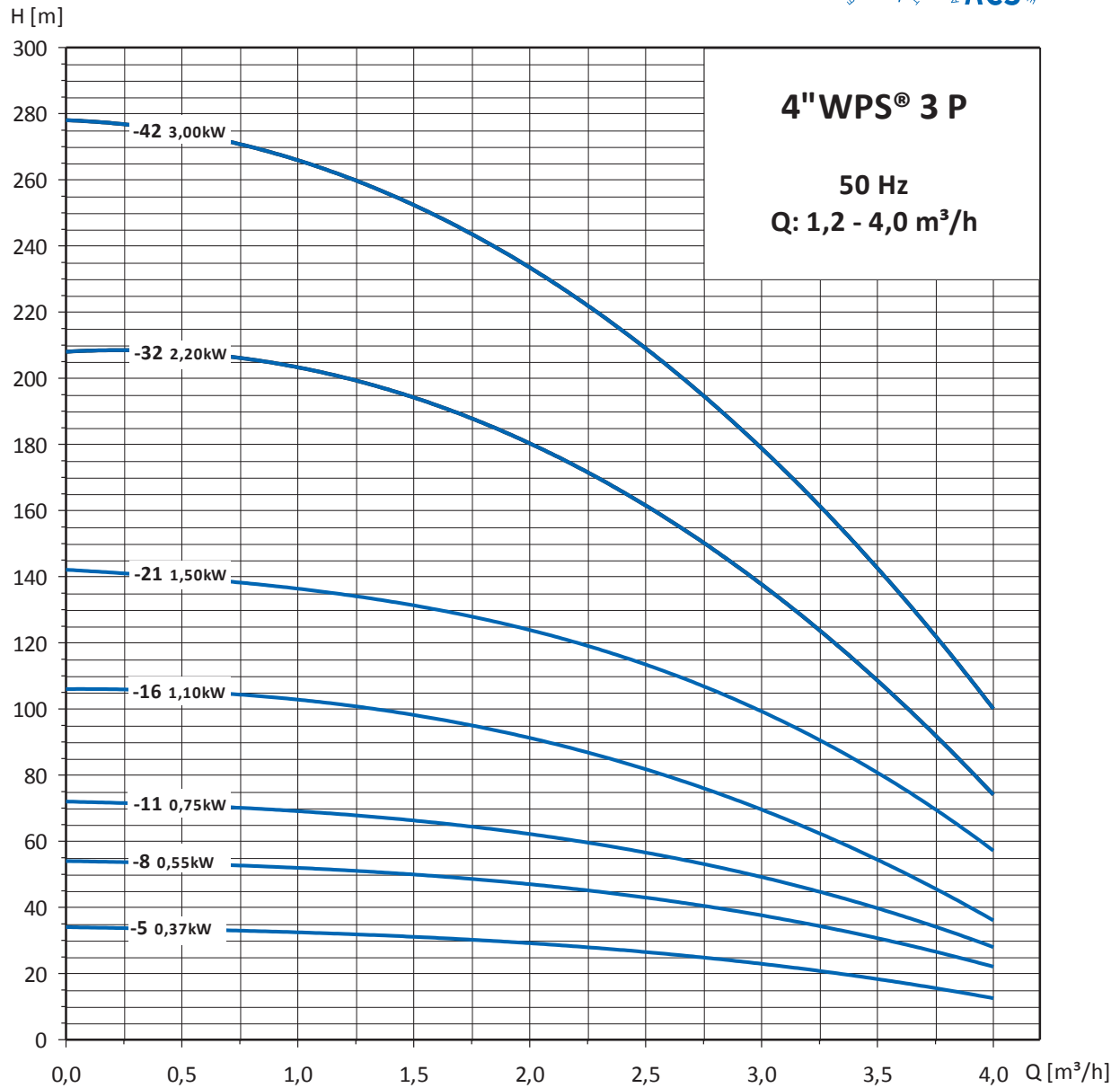

4"WPS® P

Technical Data

Selection Chart 4" WPS® 3 P

4" WPS® 3 P

Pump Type	Pump Power P ₂		Flow [m ³ /h]						Full load current	
	[kW]	[HP]	0	1,2	1,8	2,4	3,0	4,2	1x230V	3x400V
4" WPS® 3-5 P	0,37	0,50	34	32	30	27	23	11	3,4	1,3
4" WPS® 3-8 P	0,55	0,75	54	51	49	43	38	19	4,4	1,7
4" WPS® 3-11 P	0,75	1,00	72	68	64	58	49	26	6,0	2,2
4" WPS® 3-16 P	1,10	1,50	106	101	95	83	70	33	7,8	3,0
4" WPS® 3-21 P	1,50	2,00	142	135	127	115	100	49	10,5	4,0
4" WPS® 3-32 P	2,20	3,00	208	200	187	165	138	62	15,0	5,6
4" WPS® 3-42 P	3,00	4,00	278	261	242	214	179	100	-	7,5

Dimensions and Weights 4" WPS® 3 P

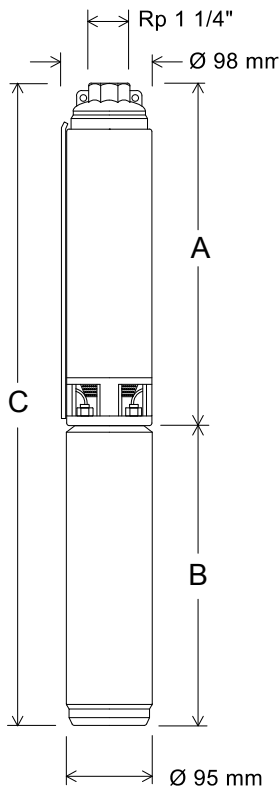

Pump Type	Pump Power P ₂		A [mm]	B [mm]	C [mm]	Weight [kg]	
	[kW]	[HP]				Pump End	Electropump
4" WPS® 3-5 P	0,37	0,50	236	235	471	2,5	8,3
4" WPS® 3-8 P	0,55	0,75	289	250	539	2,9	9,9
4" WPS® 3-11 P	0,75	1,00	342	265	607	3,4	11,7
4" WPS® 3-16 P	1,10	1,50	430	295	725	4,2	15,1
4" WPS® 3-21 P	1,50	2,00	519	340	859	5,0	16,4
4" WPS® 3-32 P	2,20	3,00	787	375	1 253	8,1	22,3
4" WPS® 3-42 P	3,00	4,00	985	480	1465	10,7	29,0

Performance Curves 4"WPS® 4 P

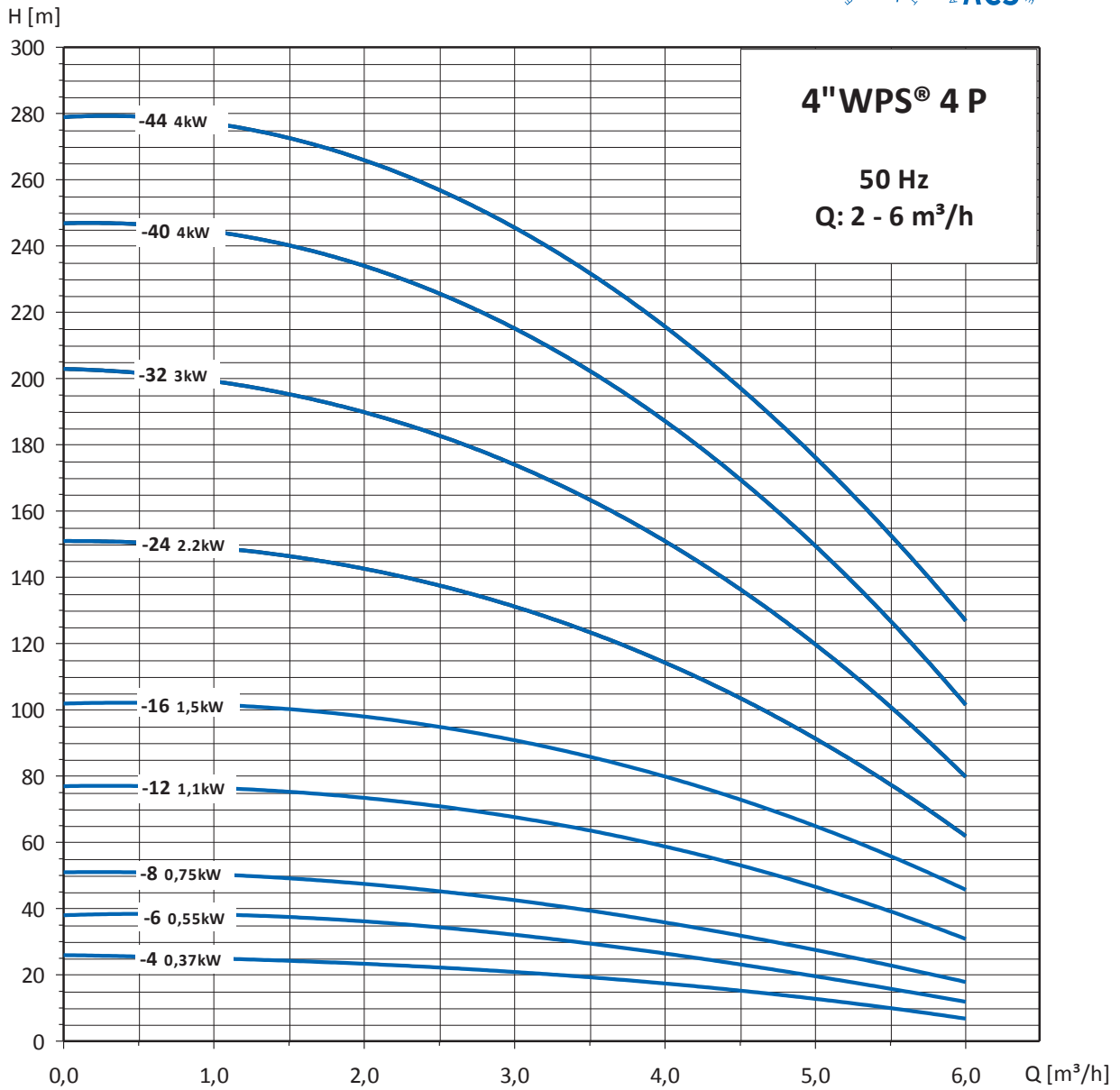

4"WPS® P

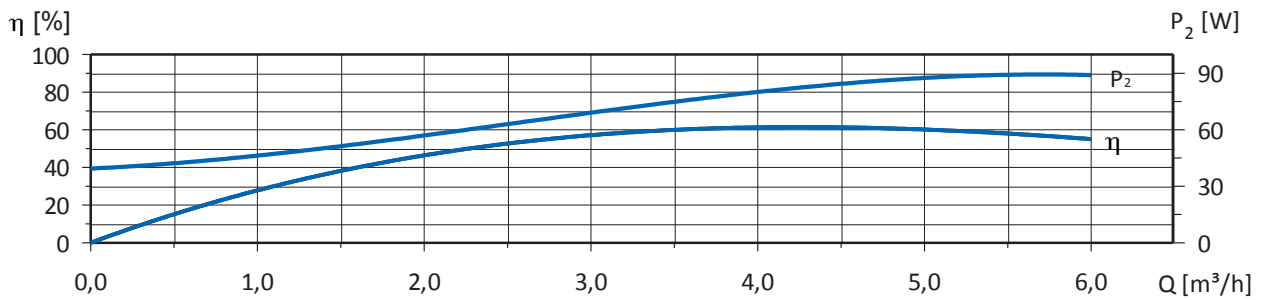

Technical Data

Selection Chart 4" WPS® 4 P

4" WPS® 4 P

Pump Type	Pump Power P ₂		Flow [m ³ /h]						Full load current	
	[kW]	[HP]	0	2,0	3,0	4,0	5,0	6,0	1x230V	3x400V
4" WPS® 4-4 P	0,37	0,50	26	23	21	18	12	7	3,4	1,3
4" WPS® 4-6 P	0,55	0,75	38	36	32	27	19	12	4,4	1,7
4" WPS® 4-8 P	0,75	1,00	51	47	43	36	27	18	6,0	2,2
4" WPS® 4-12 P	1,10	1,50	77	73	68	59	46	31	7,8	3,0
4" WPS® 4-16 P	1,50	2,00	102	97	92	80	64	46	10,5	4,0
4" WPS® 4-24 P	2,20	3,00	151	142	132	114	91	62	15,0	5,6
4" WPS® 4-32 P	3,00	4,00	203	189	175	151	119	80	-	7,5
4" WPS® 4-40 P	4,00	5,50	253	233	216	188	148	102	-	10,6
4" WPS® 4-44 P	4,00	5,50	278	265	247	215	176	127	-	10,6

Dimensions and Weights 4" WPS® 4 P

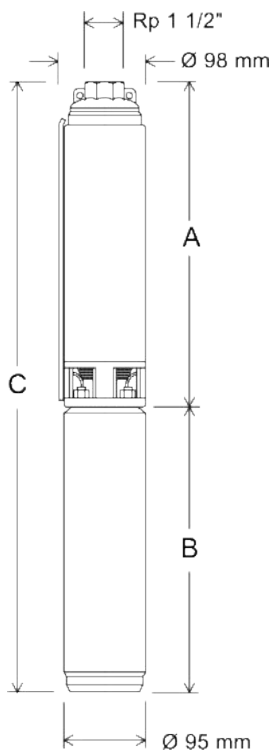

Pump Type	Pump Power P ₂		A	B	C	Weight [kg]	
	[kW]	[HP]	[mm]	[mm]	[mm]	Pump End	Electropump
4" WPS® 4-4 P	0,37	0,50	247	235	482	2,4	8,2
4" WPS® 4-6 P	0,55	0,75	296	250	546	2,9	9,9
4" WPS® 4-8 P	0,75	1,00	345	265	610	3,3	11,6
4" WPS® 4-12 P	1,10	1,50	433	295	728	4,1	15,0
4" WPS® 4-16 P	1,50	2,00	542	340	882	5,0	16,4
4" WPS® 4-24 P	2,20	3,00	815	375	1190	7,6	21,8
4" WPS® 4-32 P	3,00	4,00	1003	480	1483	9,7	28,0
4" WPS® 4-40 P	4,00	5,50	1198	555	1753	11,4	34,8
4" WPS® 4-44 P	4,00	5,50	1334	555	1889	12,2	35,6

Performance Curves 4"WPS® 6 P

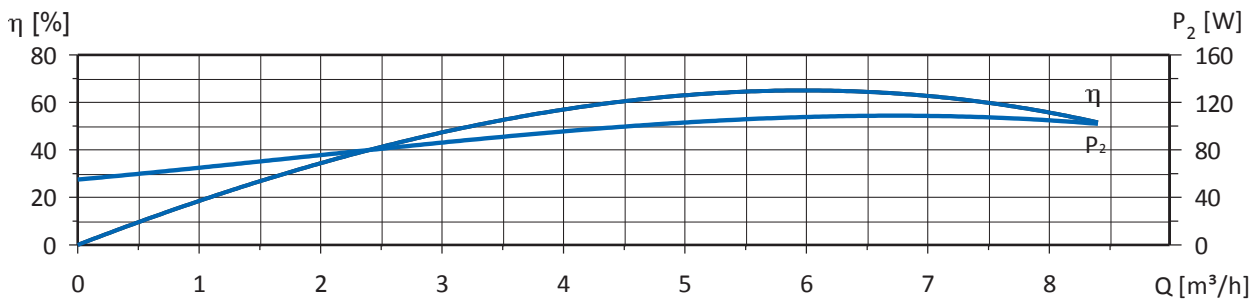
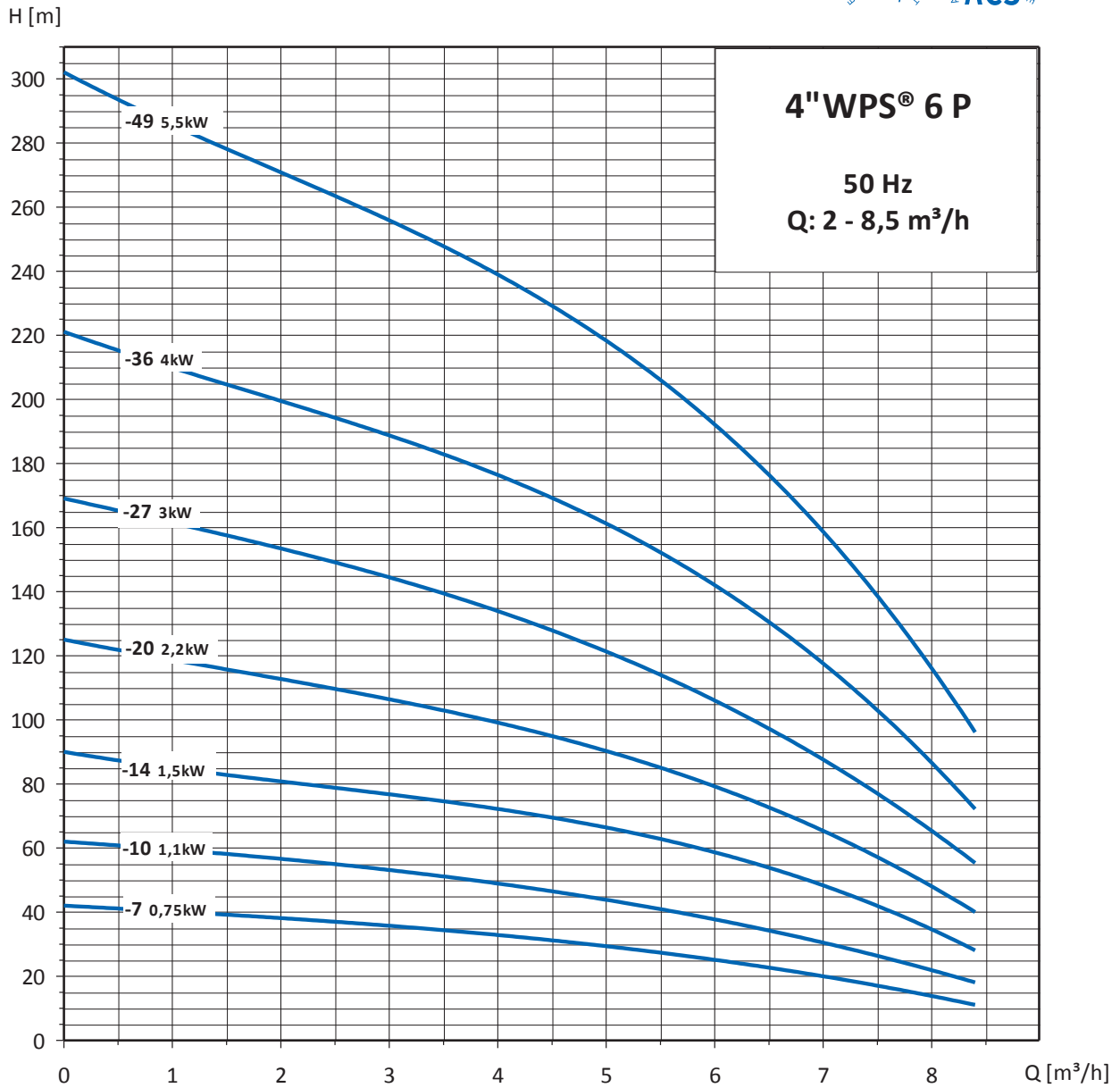

Technical Data

Selection Chart 4" WPS® 6 P

4" WPS® 6 P

Pump Type	Pump Power P ₂		Flow [m ³ /h]						Full load current	
	[kW]	[HP]	0	3,0	4,5	6,0	7,5	8.5	1x230V	3x400V
4"WPS® 6-7 P	0,75	1,00	42	36	31	25	17	11	6,0	2,2
4"WPS® 6-10 P	1,10	1,50	62	53	46	38	26	17	7,8	3,0
4"WPS® 6-14 P	1,50	2,00	90	77	69	59	42	28	10,5	4,0
4"WPS® 6-20 P	2,20	3,00	125	107	93	80	57	41	15,0	5,6
4"WPS® 6-27 P	3,00	4,00	169	145	127	107	77	55	-	7,5
4"WPS® 6-36 P	4,00	5,50	221	190	168	143	102	72	-	10,6
4"WPS® 6-49 P	5,50	7,50	302	257	227	193	135	95	-	13,6

Dimensions and Weights 4" WPS® 6 P

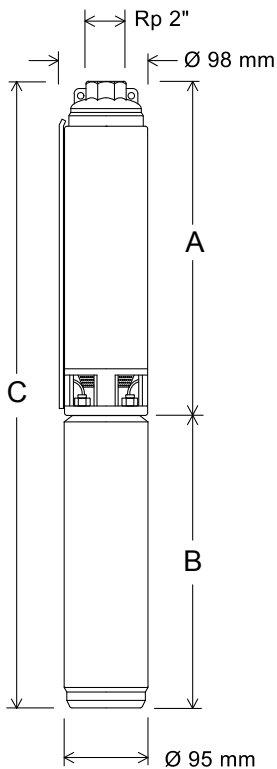

Pump Type	Pump Power P ₂		A	B	C	Weight [kg]	
	[kW]	[HP]	[mm]	[mm]	[mm]	Pump End	Electropump
4"WPS® 6-7 P	0,75	1,00	390	265	655	3,7	12,0
4"WPS® 6-10 P	1,10	1,50	483	295	778	4,6	15,5
4"WPS® 6-14 P	1,50	2,00	607	340	947	5,7	17,1
4"WPS® 6-20 P	2,20	3,00	831	375	1206	7,5	21,7
4"WPS® 6-27 P	3,00	4,00	1086	480	1566	10,6	28,9
4"WPS® 6-36 P	4,00	5,50	1356	555	1911	13,2	36,6
4"WPS® 6-49 P	5,50	7,50	1840	675	2515	16,9	46,3

Performance Curves 4"WPS® 8 P

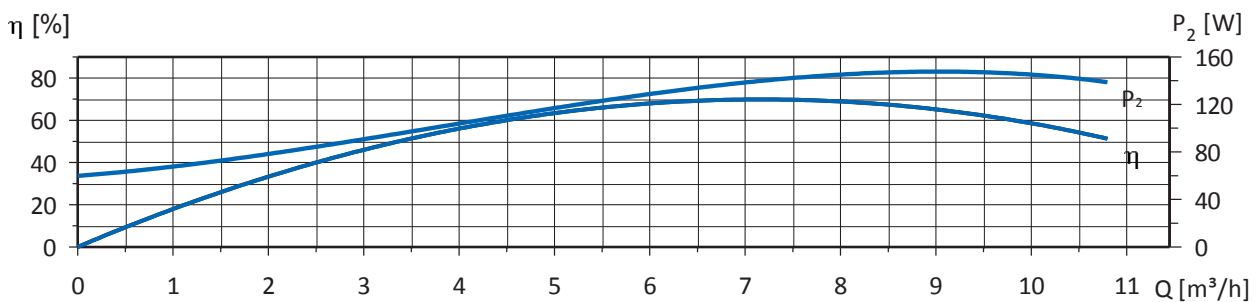
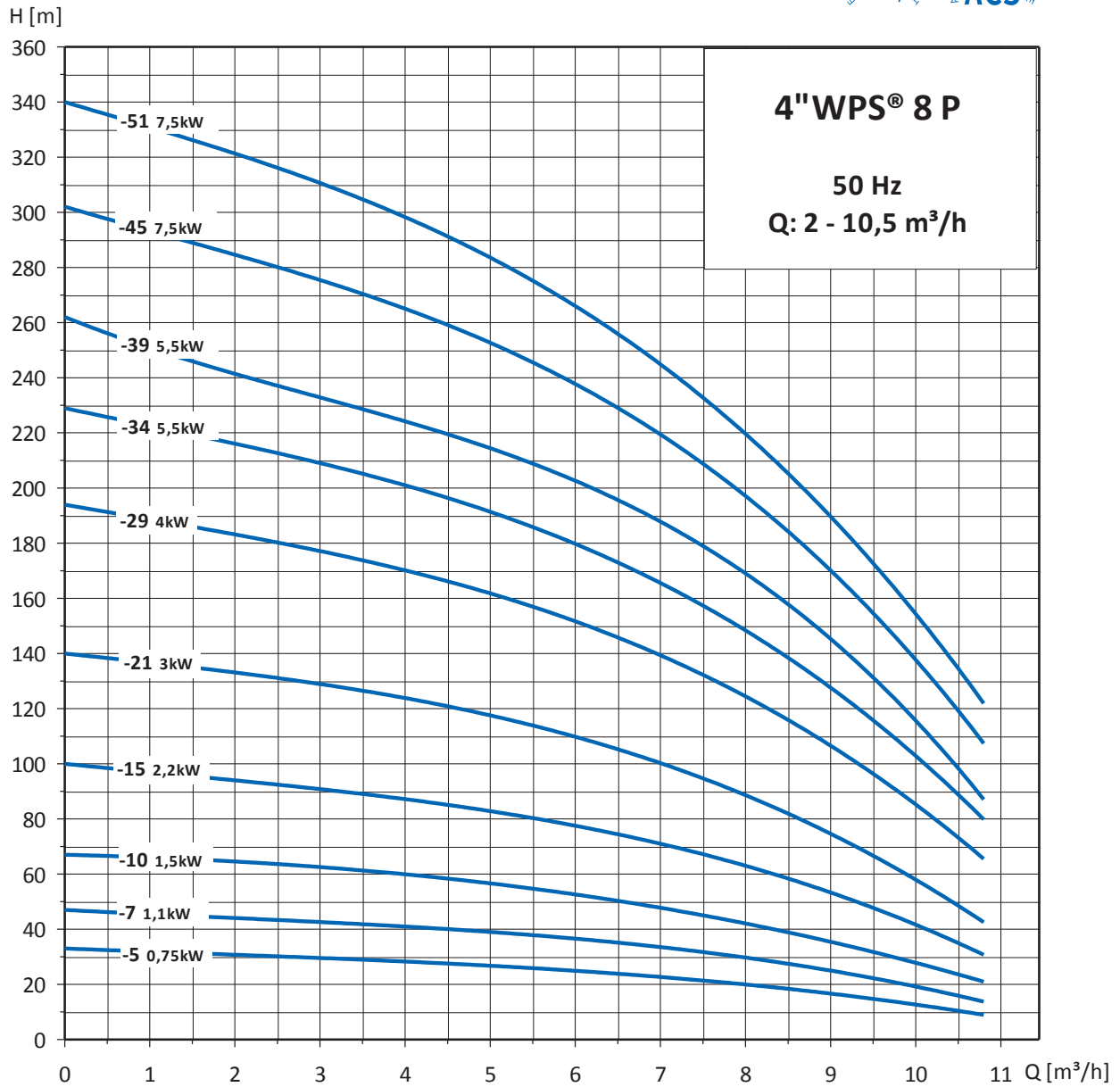

Technical Data

Selection Chart 4" WPS® 8 P

4" WPS® 8 P

Pump Type	Pump Power P ₂		Flow [m ³ /h]						Full load current	
	[kW]	[HP]	0	2	4	6	8	10	1x230V	3x400V
4" WPS® 8-5 P	0,75	1,00	33	31	28	25	20	13	6,0	2,2
4" WPS® 8-7 P	1,10	1,50	47	44	41	37	30	19	7,8	3,0
4" WPS® 8-10 P	1,50	2,00	67	59	60	53	42	27	10,5	4,0
4" WPS® 8-15 P	2,20	3,00	100	94	87	78	64	42	15,0	5,6
4" WPS® 8-21 P	3,00	4,00	140	133	124	110	88	58	-	7,5
4" WPS® 8-29 P	4,00	5,50	194	183	170	152	124	85	-	10,6
4" WPS® 8-34 P	5,50	7,50	229	216	201	180	148	103	-	13,6
4" WPS® 8-39 P	5,50	7,50	262	242	224	202	169	116	-	13,6
4" WPS® 8-45 P	7,50	10,00	302	285	265	237	197	137	-	18,3
4" WPS® 8-51 P	7,50	10,00	340	322	298	267	200	154	-	18,3

Dimensions and Weights 4" WPS® 8 P

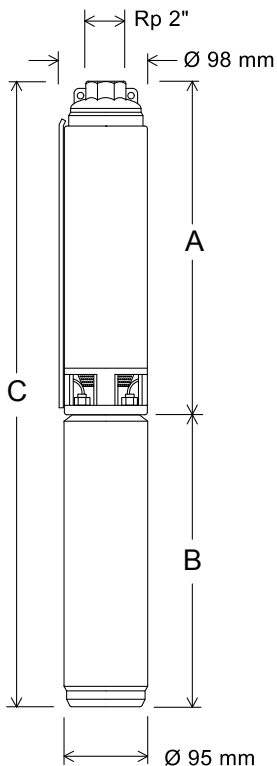

Pump Type	Pump Power P ₂		A [mm]	B [mm]	C [mm]	Weight [kg]	
	[kW]	[HP]				Pump End	Electropump
4" WPS® 8-5 P	0,75	1,00	330	265	595	3,2	11,5
4" WPS® 8-7 P	1,10	1,50	395	295	690	3,8	14,7
4" WPS® 8-10 P	1,50	2,00	485	340	825	4,6	16,0
4" WPS® 8-15 P	2,20	3,00	640	375	1015	6,1	20,3
4" WPS® 8-21 P	3,00	4,00	865	480	1345	8,2	26,5
4" WPS® 8-29 P	4,00	5,50	1150	555	1705	10,7	34,1
4" WPS® 8-34 P	5,50	7,50	1325	675	2000	13,2	42,6
4" WPS® 8-39 P	5,50	7,50	1480	675	2155	14,5	43,9
4" WPS® 8-45 P	7,50	10,00	1745	765	2510	17,1	50,9
4" WPS® 8-51 P	7,50	10,00	1930	765	2695	18,6	52,4

Performance Curves 4"WPS® 10 P

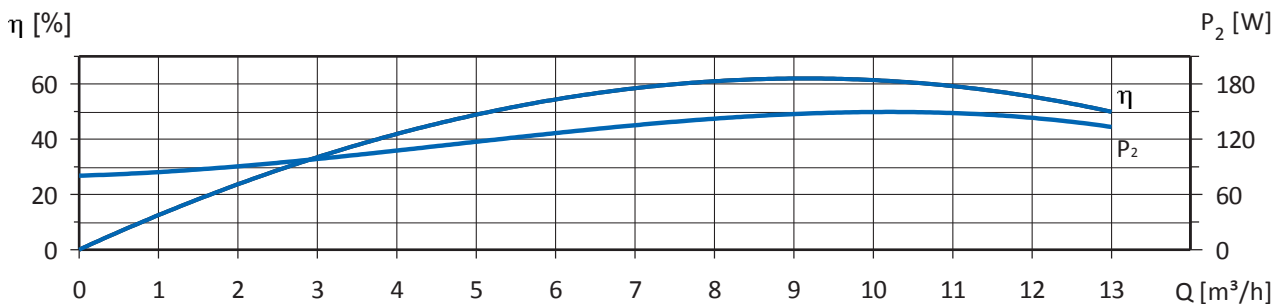
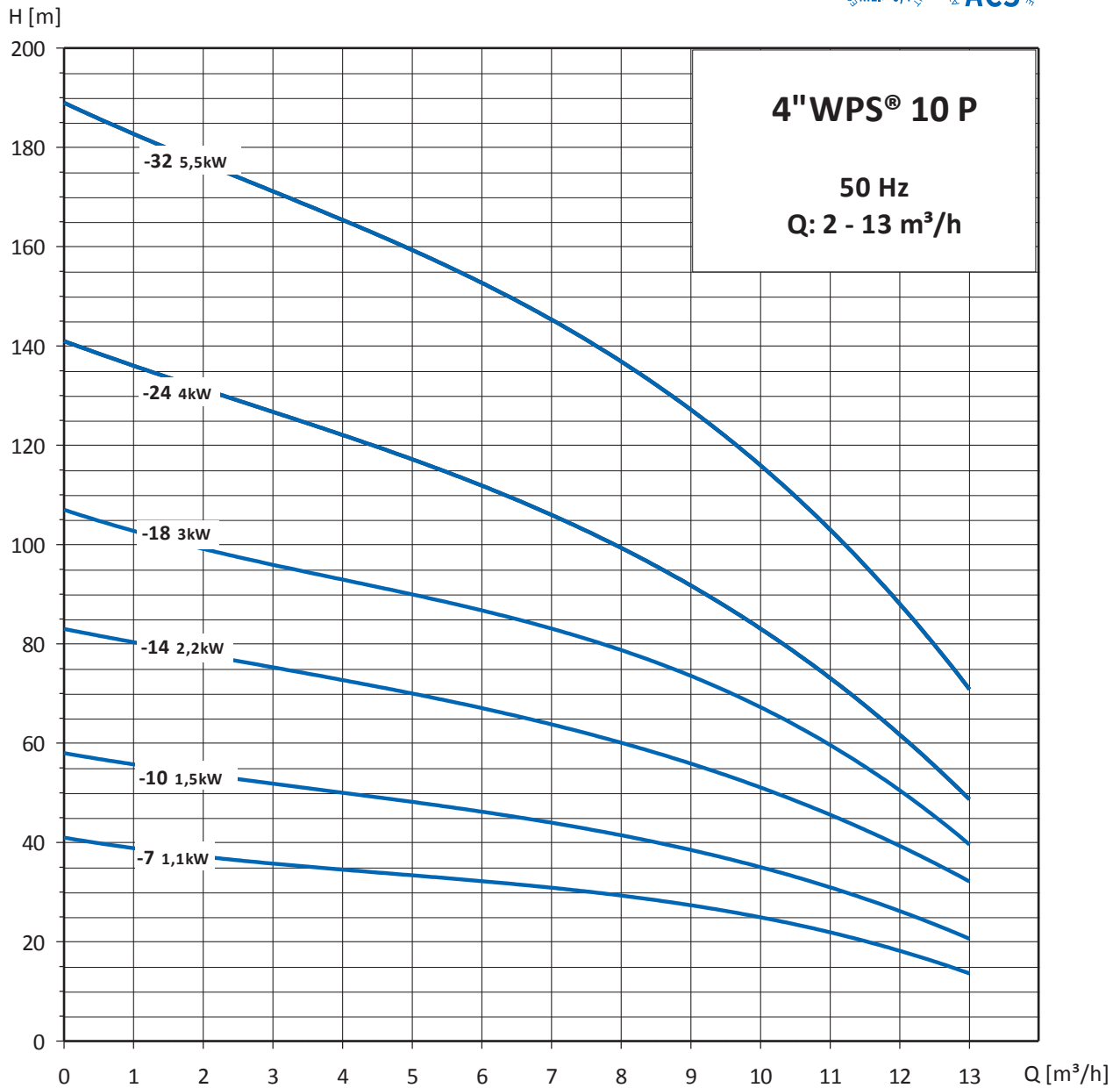

Technical Data

Selection Chart 4" WPS® 10 P

4" WPS® 10 P

Pump Type	Pump Power P ₂		Flow [m ³ /h]						Full load current	
	[kW]	[HP]	0	3	6	8	10	12	1x230V	3x400V
4" WPS® 10-7 P	1,10	1,50	41	38	33	30	25	16	7,8	3,0
4" WPS® 10-10 P	1,50	2,00	58	52	48	42	37	22	10,5	4,0
4" WPS® 10-14 P	2,20	3,00	83	76	69	60	52	33	15,0	5,6
4" WPS® 10-18 P	3,00	4,00	107	98	90	78	68	42	-	7,5
4" WPS® 10-24 P	4,00	5,50	141	117	113	100	85	54	-	10,6
4" WPS® 10-32 P	5,50	7,50	189	172	153	137	115	74	-	13,6

Dimensions and Weights 4" WPS® 10 P

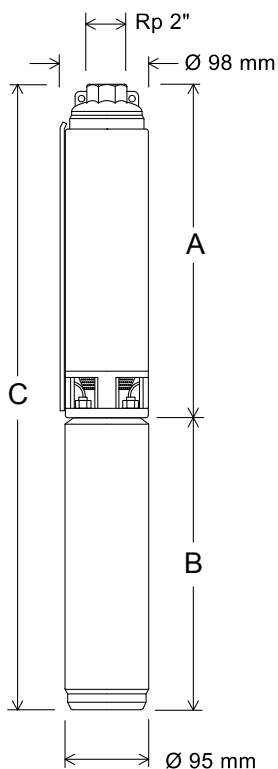

Pump Type	Pump Power P ₂		A	B	C	Weight [kg]	
	[kW]	[HP]	[mm]	[mm]	[mm]	Pump End	Electropump
4" WPS® 10-7 P	1,10	1,50	537	295	832	5,3	16,2
4" WPS® 10-10 P	1,50	2,00	693	340	1033	6,7	18,1
4" WPS® 10-14 P	2,20	3,00	901	375	1276	8,5	22,7
4" WPS® 10-18 P	3,00	4,00	1185	480	1665	11,4	29,7
4" WPS® 10-24 P	4,00	5,50	1487	555	2042	14,2	37,6
4" WPS® 10-32 P	5,50	7,50	1904	675	2579	18,0	47,4

Performance Curves 4"WPS® 12 P

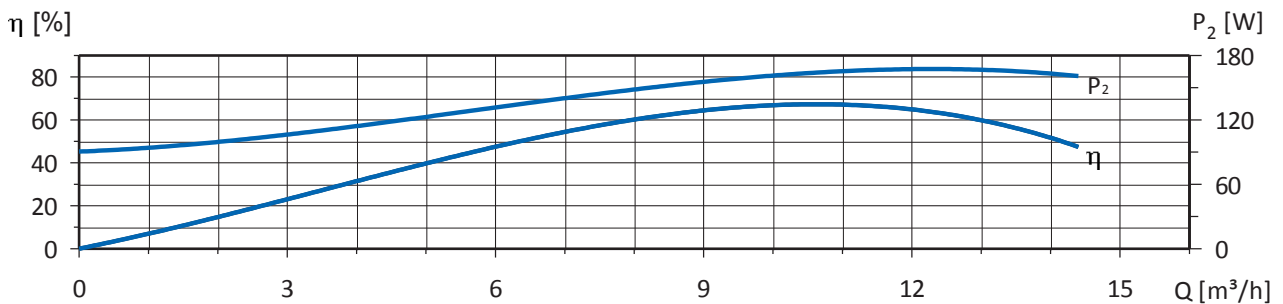
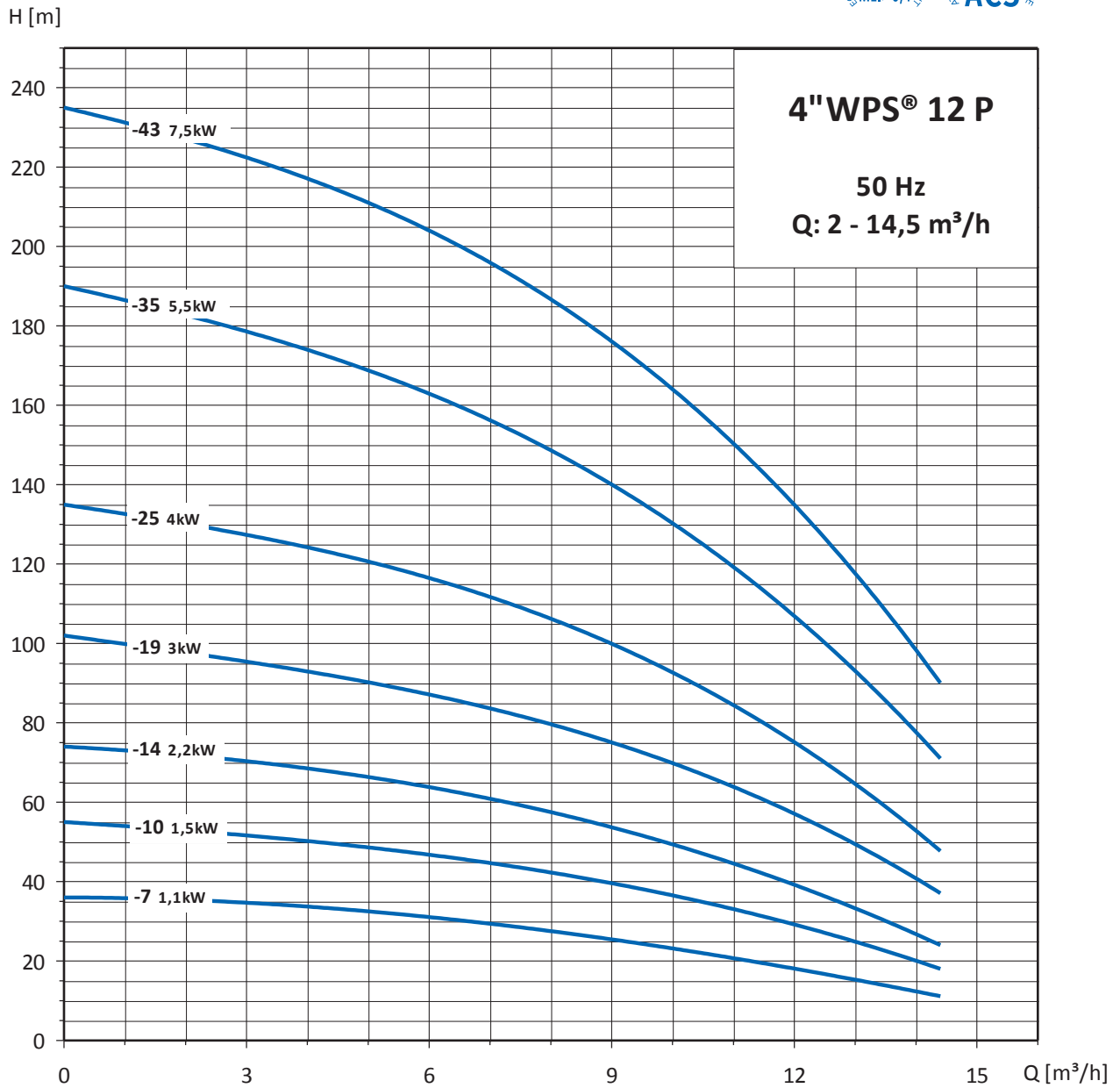

Technical Data

Selection Chart 4" WPS® 12 P

4" WPS® P

Pump Type	Pump Power P ₂		Flow [m ³ /h]						Full load current	
	[kW]	[HP]	0	3	6	9	12	14	1x230V	3x400V
4" WPS® 12-7 P	1,10	1,50	36	35	31	25	18	13	7,8	3,0
4" WPS® 12-10 P	1,50	2,00	55	52	47	39	29	20	10,5	4,0
4" WPS® 12-14 P	2,20	3,00	74	70	64	54	39	27	15,0	5,6
4" WPS® 12-19 P	3,00	4,00	102	96	87	75	57	41	-	7,5
4" WPS® 12-25 P	4,00	5,50	135	127	116	100	75	53	-	10,6
4" WPS® 12-35 P	5,50	7,50	190	179	163	140	107	78	-	13,6
4" WPS® 12-43 P	7,50	10,00	235	222	204	176	135	99	-	18,3

Dimensions and Weights 4" WPS® 12 P

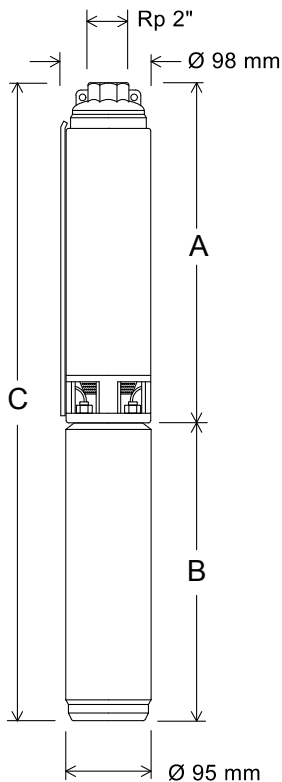

Pump Type	Pump Power P ₂		A	B	C	Weight [kg]	
	[kW]	[HP]	[mm]	[mm]	[mm]	Pump End	Electropump
4" WPS® 12-7 P	1,10	1,50	540	295	835	4,9	15,8
4" WPS® 12-10 P	1,50	2,00	695	340	1035	6,3	17,7
4" WPS® 12-14 P	2,20	3,00	905	375	1280	8,1	22,3
4" WPS® 12-19 P	3,00	4,00	1240	480	1720	11,0	29,3
4" WPS® 12-25 P	4,00	5,50	1570	555	2125	14,3	37,7
4" WPS® 12-35 P	5,50	7,50	2165	675	2840	19,8	49,2
4" WPS® 12-43 P	7,50	10,00	2585	765	3350	24,0	57,8

Performance Curves 4"WPS® 16 P

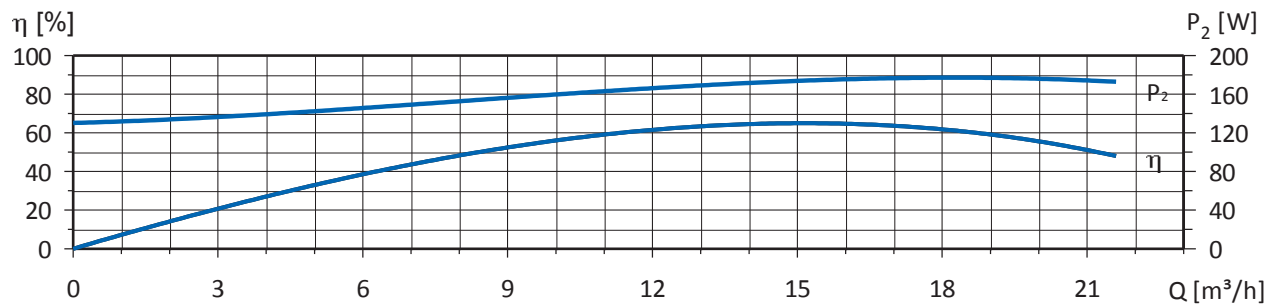
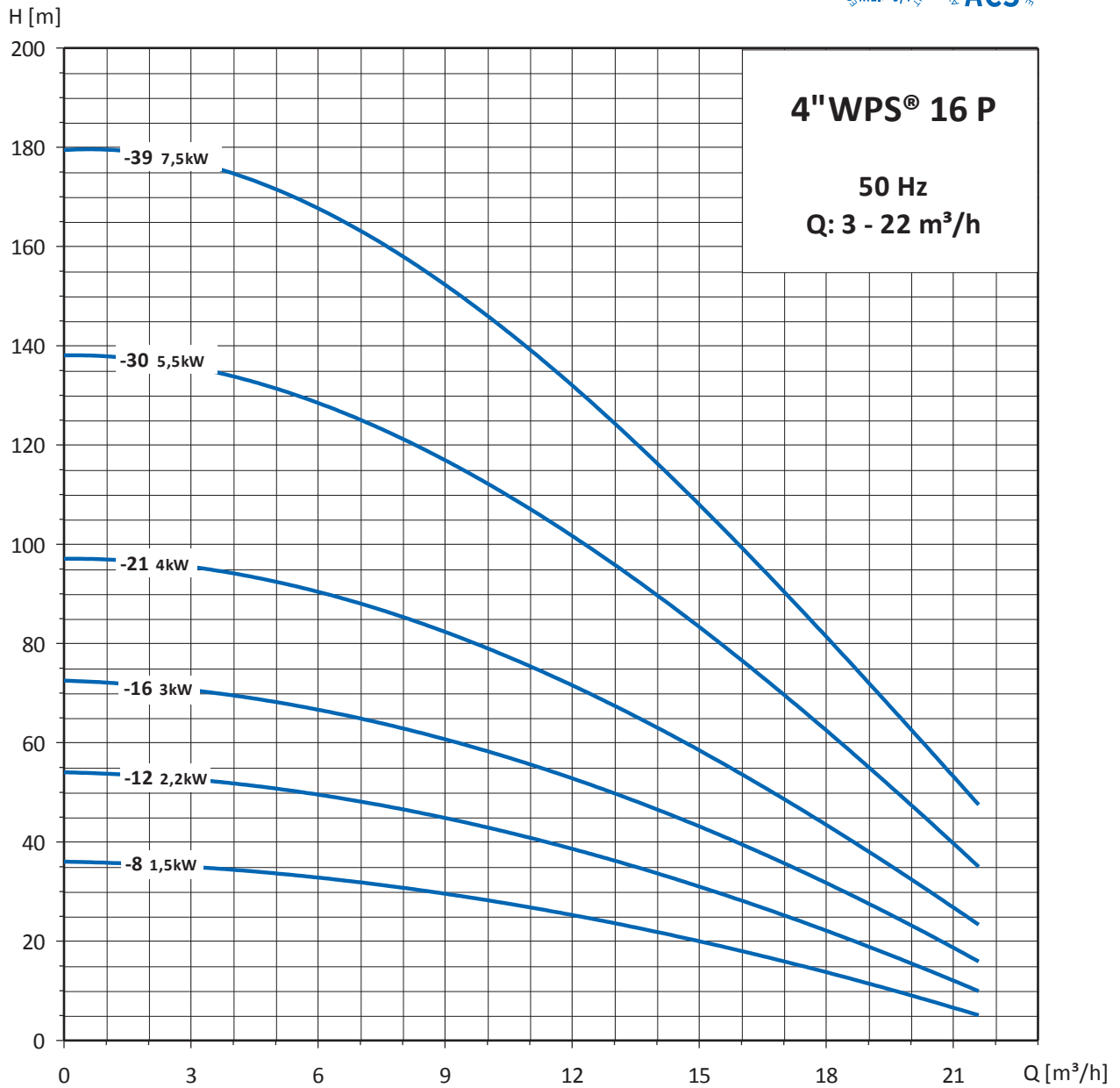

Technical Data

Selection Chart 4" WPS® 16 P

4" WPS®

Pump Type	Pump Power P ₂		Flow [m ³ /h]						Full load current	
	[kW]	[HP]	0	4	8	12	16	20	1x230V	3x400V
4" WPS® 16-8 P	1,50	2,00	36	34	31	25	18	9	10,5	4,0
4" WPS® 16-12 P	2,20	3,00	54	52	46	39	28	16	15,0	5,6
4" WPS® 16-16 P	3,00	4,00	73	69	63	53	40	24	-	7,5
4" WPS® 16-21 P	4,00	5,50	97	94	86	71	54	38	-	10,6
4" WPS® 16-30 P	5,50	7,50	138	134	122	101	76	53	-	13,6
4" WPS® 16-39 P	7,50	10,00	179	174	159	131	99	69	-	18,3

Dimensions and Weights 4" WPS® 16 P

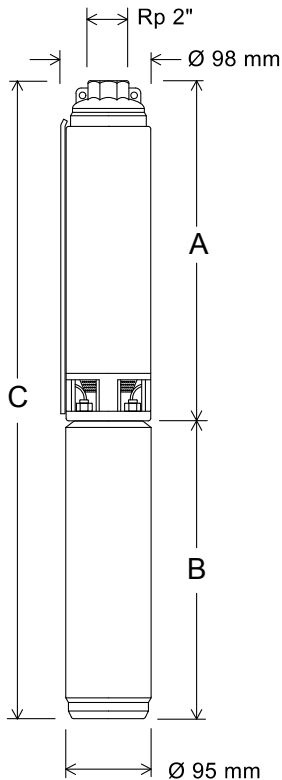

Pump Type	Pump Power P ₂		A	B	C	Weight [kg]	
	[kW]	[HP]	[mm]	[mm]	[mm]	Pump End	Electropump
4" WPS® 16-8 P	1,50	2,00	680	340	1020	6,1	17,5
4" WPS® 16-12 P	2,20	3,00	950	375	1325	8,4	22,6
4" WPS® 16-16 P	3,00	4,00	1220	480	1700	10,8	29,1
4" WPS® 16-21 P	4,00	5,50	1610	555	2165	14,7	38,1
4" WPS® 16-30 P	5,50	7,50	2225	675	2900	20,1	49,5
4" WPS® 16-39 P	7,50	10,00	2840	765	3605	25,5	59,3

Cooling Shrouds

The cooling shrouds are designed to ensure a sufficient flow velocity past the motor in order to provide sufficient cooling. For the following cases a cooling shroud is recommended:

- horizontal or vertical installation in a tank
- installation of the pump in the screen from the well
- installation in big sized well not ensuring enough cooling velocity. See table.

Minimum flow required for motor cooling in water up to 20°C.	
Casing or sleeve I.D. [mm (inches)]	4" motor, cooling flow 8 cm/sec [m ³ /h]
102 (4")	0,3
127 (5")	1,6
152 (6")	3,0
203 (8")	6,9
254 (10")	11,4
305 (12")	18,2

To the shroud itself, a screen can be added. In case of horizontal installation a set of supports are available.



Description	Material	Fits to pump type	Reference
Shroud Ø 115 x 400 mm	1.4301-AISI 304	4"WPS 1,5-5 up to 15 4"WPS 2,5-4 up to 12 4"WPS 4-3 up to 9 4"WPS 7-2 up to 6 4"WPS 13-3	74010
Shroud Ø 115 x 500 mm	1.4301-AISI 304	4"WPS 1,5-19 up to 46 4"WPS 2,5-15 up to 37 4"WPS 4-13 up to 27 4"WPS 7-9 up to 18 4"WPS 13-4 up to 8	74020
Shroud Ø 115 x 625 mm	1.4301-AISI 304	4"WPS 1,5-52 up to 62 4"WPS 2,5-44 up to 51 4"WPS 4-32 up to 37 4"WPS 7-22 up to 25 4"WPS 13-11 up to 13	74030
Shroud Ø 115 x 800 mm	1.4301-AISI 304	4"WPS 2,5-57 up to 67 4"WPS 4-42 up to 67 4"WPS 7-28 up to 46 4"WPS 13-15 up to 23	74040
Shroud Ø 115 x 1000 mm	1.4301-AISI 304	4"WPS 7-52 up to 62 4"WPS 13-27 up to 30	74050



Screen Ø 115 x 117 mm	1.4301-AISI 304	For all models	74300
-----------------------	-----------------	----------------	-------



Set of supports for shroud with lenght 400 or 500 mm	1.4301-AISI 304	Fits to reference 74010 and 74020	74400
Set of supports for shroud with lenght 625 or 1000 mm	1.4301-AISI 304	Fits to reference 74030, 74040 and 74050	74410

Cooling schrouds in material 1.4401 - AISI 316 are available upon request

General Data

All the internal and external metal components of the 6" WPS® pumps are constructed out of stainless steel AISI 304 or AISI 316 throughout and are being cold pressed from stainless steel sheet.

6" WPS® submersible pumps are suitable for both continuous and intermittent operation for a variety of applications:

- General water supply
- Waterworks and fountains
- Irrigation
- Tank applications
- Pressure boosting
- Heating pumps
- Dewatering, mining and other industrial applications

Note: For other applications, please contact Well Pumps.



6" WPS®

Pump and motor range

6" WPS® pump range consists of four nominal flow models: 16, 30, 45, 60 and 75 m³/h.

The pump-end is entirely made out of Stainless Steel DIN 1.4301, AISI 304 or DIN 1.4401, AISI 316 for the N version.

The pumps are standard equipped with a 4" motor up to 5,5kW and a 6" submersible motor from 7,5kW up to 45kW power.

Construction of the pump



Impeller and conical bush

- 1 Strong conical bush system to fix the impeller to the shaft
- 2 Strong welding of each vane to the impeller discs.
- 3 4 impeller shapes giving four flow models
- 4 Stainless steel sheet with a minimum thickness of 1,5 mm

Diffuser

- 5 Stainless steel sheet with a minimum thickness of 1,5 mm
- 6 Generously dimensioned intermediate bearing in NBR at each pump stage
- 7 Neck ring in NBR with reinforced stainless steel ring

Top Bearing

- 8 Important water-lubricated upper bearing in NBR for each pump

Shaft

- 9 Round shaft in stainless steel AISI 431-1.4057 or AISI 904L - 1.4539 for the N version.
- 10 High-quality coupling made of full stainless steel bar

Pipe connection

All pump types have a treaded pipe connection:

6" WPS® 16: Rp 2 1/2"

6" WPS® 30: Rp 3"

6" WPS® 45: Rp 3"

6" WPS® 60: Rp 4"

6" WPS® 75: Rp 4"

Flange adapters are available upon request

Pump identification code

Example

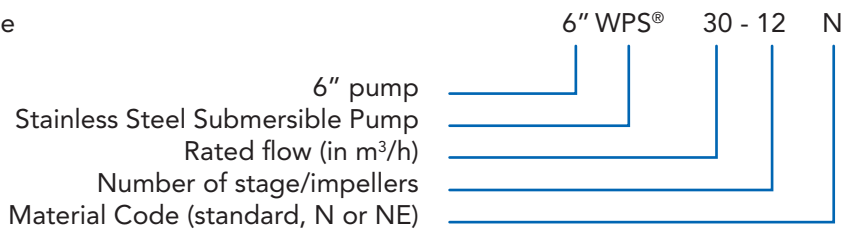

Pumped liquids

6" WPS® submersible pumps are designed for pumping thin, clean, non-aggressive and non-explosive liquids, not containing solid particles.

6" WPS® pumps are suitable for pumping liquids with a content of sand up to 150 g/m³. A higher content of sand will shorten pump life.

The maximum fluid temperature is 35°C. For higher temperatures, please contact Well Pumps.

Construction features

- Coupling and motor flange of pump-end are suitable for connection to motors in accordance with NEMA standard.
- Jam free check valve, built in the discharge chamber, is designed for low loss of head.
- Generously dimensioned intermediate bearing located at each stage of the pump in order to perfectly align the shaft and optimize the lubrication.
- Rugged cable guards.
- Hydraulic profiles are optimized for the attainment of high efficiencies.
- Resistance to corrosion and abrasion, i.e. the same inherent qualities of stainless steel (AISI 304 or AISI 316). Model 6" WPS® 75 is also available in Duplex steel.
- Great ease of dismantling and assembly.

Curve Conditions

- Curve tolerances according to ISO 9906, 2012 Class 3B.
- The performance curves show pump performance at actual speed of the standard motor range.
- The measurements were made with airless water at a temperature of 20°C and a kinematic viscosity of 1 mm²/s (1 cSt). For pumping liquids with a higher density than clear water, motors must be used with correspondingly higher outputs.
- Q/H: The curves are inclusive of valve and inlet losses at the actual speed.
- Power curve: P₂ shows pump input power at the actual speed for each individual pump size.
- Efficiency curve: η shows pump efficiency.

Service

The pump and motor are very easy to maintain and repair. The modular pump and motor design facilitates installation and service.

Performance Curves

Performance Curves 6"WPS® 16 and 6"WPS® 16 N(E)



6"WPS®

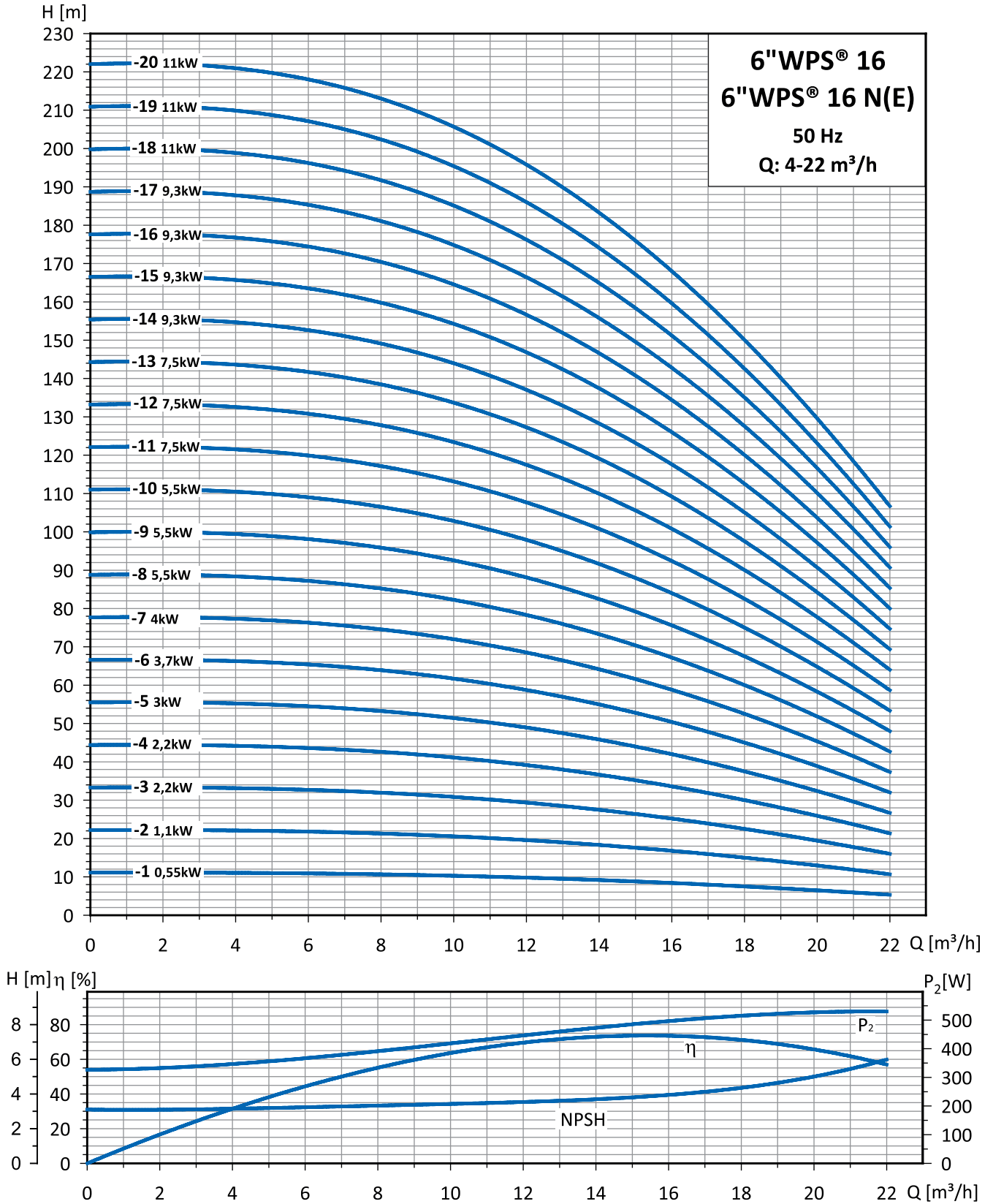

Performance Curves 6"WPS® 16 and 6"WPS® 16 N(E)

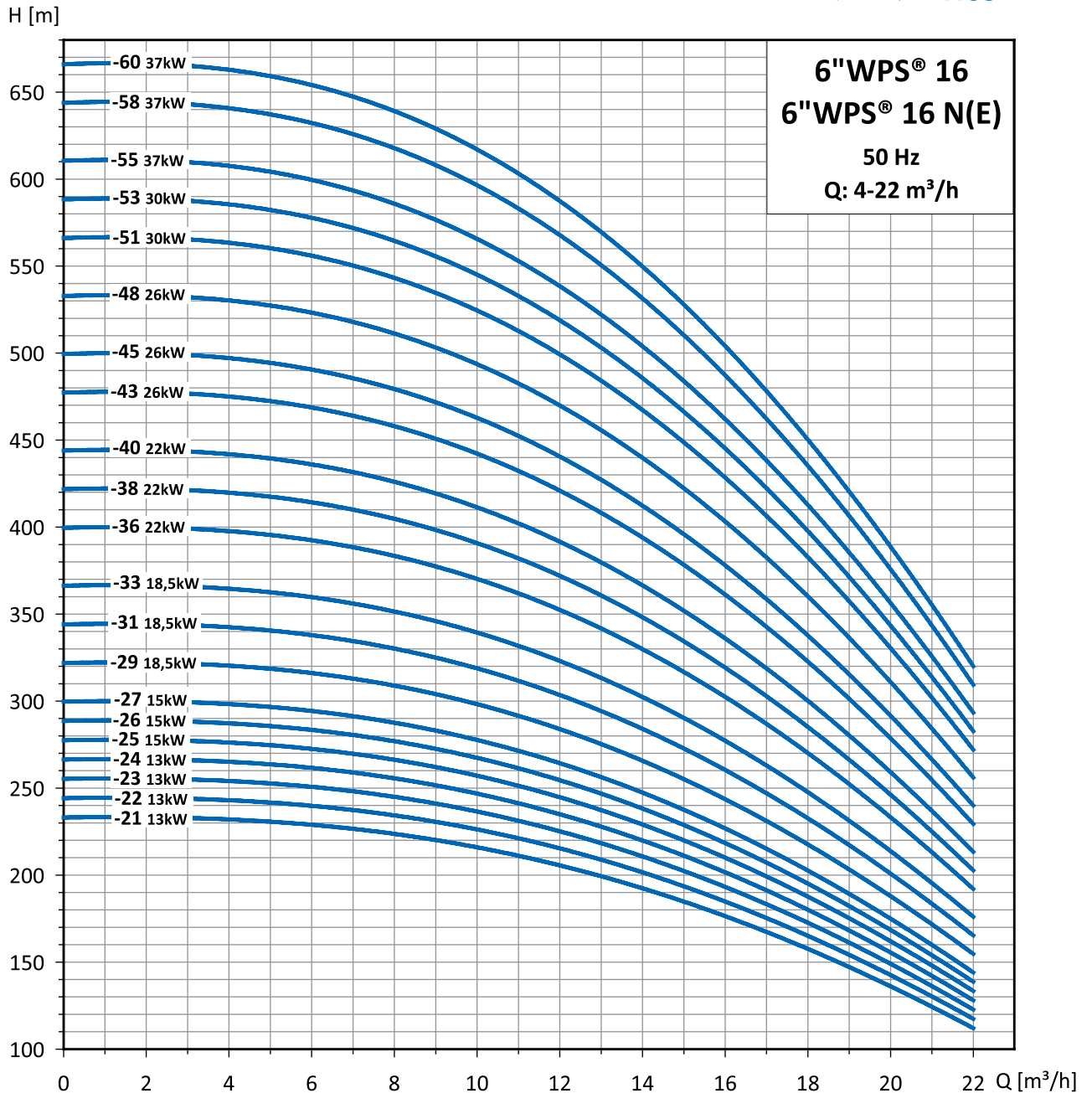

6"WPS®

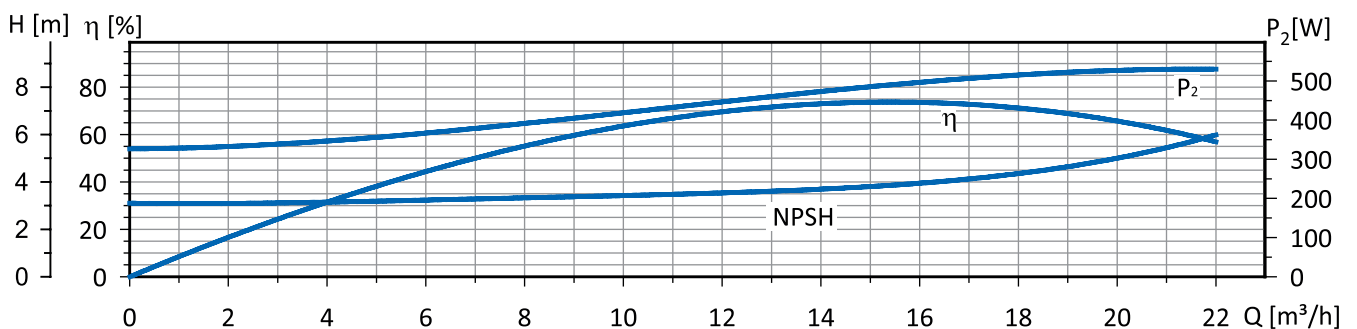

Technical Data

Selection Chart 6"WPS® 16 and 6"WPS® 16 N(E)

Pump Type	Pump Power P ₂		Flow [m ³ /h]							Full load current	
	[kW]	[HP]	0	6	10	13	16	19	22	3x230V	3x400V
6"WPS® 16-1	0,55	0,75	11	11	10	9	8	7	5	2,8	1,6
6"WPS® 16-2	1,1	1,5	22	22	21	19	17	14	11	4,9	2,8
6"WPS® 16-3	2,2	3	33	33	31	28	25	21	16	9,0	5,1
6"WPS® 16-4	2,2	3	44	44	41	38	34	28	21	9,4	5,4
6"WPS® 16-5	3	4	56	55	52	47	42	35	27	12,8	7,3
6"WPS® 16-6	3,7	5	67	65	62	57	51	42	32	15,0	8,4
6"WPS® 16-7	4	5,5	78	76	72	66	59	49	37	17,0	9,7
6"WPS® 16-8	5,5	7,5	89	87	82	76	68	56	43	17,6	10,5
6"WPS® 16-9	5,5	7,5	100	98	93	85	76	63	48	20,2	11,2
6"WPS® 16-10	5,5	7,5	111	109	103	95	85	70	53	21,7	12,3
6"WPS® 16-11	7,5	10	122	120	113	104	93	77	59	24,9	13,5
6"WPS® 16-12	7,5	10	133	131	124	113	101	84	64	25,8	14,4
6"WPS® 16-13	7,5	10	144	142	134	123	110	91	69	27,7	16,0
6"WPS® 16-14	9,3	12,5	155	153	144	132	118	98	75	32,8	17,9
6"WPS® 16-15	9,3	12,5	167	164	155	142	127	105	80	33,6	18,7
6"WPS® 16-16	9,3	12,5	178	174	165	151	135	112	85	35,1	19,9
6"WPS® 16-17	9,3	12,5	189	185	175	161	144	119	91	36,0	20,7
6"WPS® 16-18	11	15	200	196	185	170	152	126	96	37,9	21,0
6"WPS® 16-19	11	15	211	207	196	180	161	133	101	39,2	22,6
6"WPS® 16-20	11	15	222	218	206	189	169	140	107	40,4	23,3
6"WPS® 16-21	13	17,5	233	229	216	198	177	147	112	-	25,5
6"WPS® 16-22	13	17,5	244	240	227	208	186	154	117	-	26,3
6"WPS® 16-23	13	17,5	255	251	237	217	194	161	123	-	28,4
6"WPS® 16-24	13	17,5	266	262	247	227	203	168	128	-	29,6
6"WPS® 16-25	15	20	278	273	258	236	211	175	134	50,6	27,8
6"WPS® 16-26	15	20	289	283	268	246	220	181	139	52,0	29,0
6"WPS® 16-27	15	20	300	294	278	255	228	188	144	54,2	31,3
6"WPS® 16-29	18,5	25	322	316	299	274	245	202	155	59,0	31,6
6"WPS® 16-31	18,5	25	344	338	319	293	262	216	166	61,5	34,0
6"WPS® 16-33	18,5	25	366	360	340	312	279	230	176	66,7	38,3
6"WPS® 16-36	22	30	400	392	371	340	304	251	192	73,8	40,5
6"WPS® 16-38	22	30	422	414	391	359	321	265	203	76,3	43,1
6"WPS® 16-40	22	30	444	436	412	378	338	279	214	78,5	45,2
6"WPS® 16-43	26	35	477	469	443	406	363	300	230	-	51,0
6"WPS® 16-45	26	35	500	491	464	425	380	314	240	-	53,6
6"WPS® 16-48	26	35	533	523	494	454	406	335	256	-	56,7
6"WPS® 16-51	30	40	566	556	525	482	431	356	272	102	59,7
6"WPS® 16-53	30	40	588	578	546	501	448	370	283	107	63,5
6"WPS® 16-55	37	50	611	600	567	520	465	384	294	-	65,7
6"WPS® 16-58	37	50	644	632	597	548	490	405	310	-	72,1
6"WPS® 16-60	37	50	666	654	618	567	507	419	320	-	77,9

Dimensions and Weights 6"WPS® 16 and 6"WPS® 16 N(E)

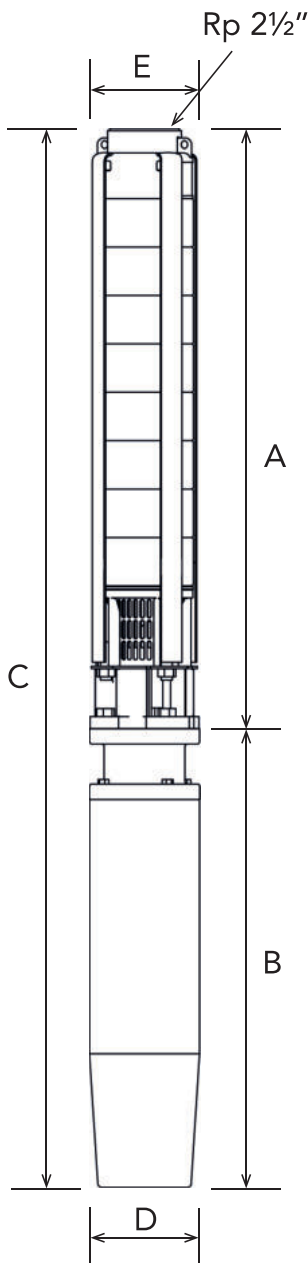

Pump Type	A [mm]	B [mm]	C [mm]	D [mm]	E [mm]	E* [mm]	Motor Type	Weight [kg]	
								Pump end	Electropump
6"WPS® 16-1	321	288	549	95	138	-	4"	6,3	15,2
6"WPS® 16-2	381	283	664	95	138	-	4"	7,6	20,1
6"WPS® 16-3	442	339	781	95	138	-	4"	8,9	23,3
6"WPS® 16-4	502	339	841	95	138	-	4"	10,2	24,6
6"WPS® 16-5	563	477	1040	95	138	-	4"	11,5	30,4
6"WPS® 16-6	623	520	1143	95	138	-	4"	12,8	33,7
6"WPS® 16-7	684	543	1227	95	138	-	4"	14,0	35,8
6"WPS® 16-7	684	581	1265	136	140	141	6"	15,5	54,8
6"WPS® 16-8	744	653	1397	95	138	-	4"	15,3	44,0
6"WPS® 16-8	747	614	1361	136	140	141	6"	16,8	59,7
6"WPS® 16-9	805	653	1458	95	138	-	4"	16,6	45,3
6"WPS® 16-9	808	614	1422	136	140	141	6"	18,1	61,0
6"WPS® 16-10	865	653	1518	95	138	-	4"	17,9	46,6
6"WPS® 16-10	868	614	1482	136	140	141	6"	19,4	62,3
6"WPS® 16-11	926	730	1656	95	138	-	4"	19,2	47,9
6"WPS® 16-11	929	646	1575	136	140	141	6"	20,7	67,7
6"WPS® 16-12	986	730	1716	95	138	-	4"	20,5	53,2
6"WPS® 16-12	989	646	1635	136	140	141	6"	22,0	69,0
6"WPS® 16-13	1047	730	1777	95	138	-	4"	21,8	54,5
6"WPS® 16-13	1050	646	1696	136	140	141	6"	23,3	70,3
6"WPS® 16-14	1110	679	1789	136	140	141	6"	24,5	74,0
6"WPS® 16-15	1171	679	1850	136	140	141	6"	25,8	75,3
6"WPS® 16-16	1231	679	1910	136	140	141	6"	27,1	76,6
6"WPS® 16-17	1292	679	1971	136	140	141	6"	28,4	77,9
6"WPS® 16-18	1352	711	2063	136	140	141	6"	29,7	81,4
6"WPS® 16-19	1413	711	2124	136	140	141	6"	31,0	82,7
6"WPS® 16-20	1473	711	2184	136	140	141	6"	32,2	83,9
6"WPS® 16-21	1534	829	2363	144	144	144	6"	33,5	94,5
6"WPS® 16-22	1594	829	2423	144	144	144	6"	34,8	95,8
6"WPS® 16-23	1655	829	2484	144	144	144	6"	36,1	97,1
6"WPS® 16-24	1715	829	2544	144	144	144	6"	37,4	98,4
6"WPS® 16-25	1776	776	2552	136	140	141	6"	38,7	97,2
6"WPS® 16-26	1836	776	2612	136	140	141	6"	40,0	98,5
6"WPS® 16-27	1897	776	2673	136	140	141	6"	41,2	99,7
6"WPS® 16-29	2018	842	2860	136	140	141	6"	43,8	108,9
6"WPS® 16-31	2139	842	2981	136	140	141	6"	46,4	111,5
6"WPS® 16-33	2260	842	3102	136	140	141	6"	48,9	114,0
6"WPS® 16-36	2441	907	3348	136	140	141	6"	52,8	124,3
6"WPS® 16-38	2562	907	3469	136	140	141	6"	55,4	126,9
6"WPS® 16-40	2683	907	3590	136	140	141	6"	57,9	129,4
6"WPS® 16-43	2865	1114	3979	144	173	176	6"	97,6	187,6
6"WPS® 16-45	2986	1114	4100	144	173	176	6"	101,7	191,7
6"WPS® 16-48	3167	1114	4281	144	173	176	6"	107,8	197,8
6"WPS® 16-51	3349	1037	4386	136	173	176	6"	113,9	199,6
6"WPS® 16-53	3470	1037	4507	136	173	176	6"	118,0	203,7
6"WPS® 16-55	3591	1421	5012	144	173	176	6"	122,1	255,1
6"WPS® 16-58	3772	1421	5193	144	173	176	6"	128,2	261,2
6"WPS® 16-60	3893	1421	5314	144	173	176	6"	132,3	265,3

* With 2 cable guards

Performance Curves

Performance Curves 6"WPS® 30 and 6"WPS® 30 N(E)



6"WPS® 30

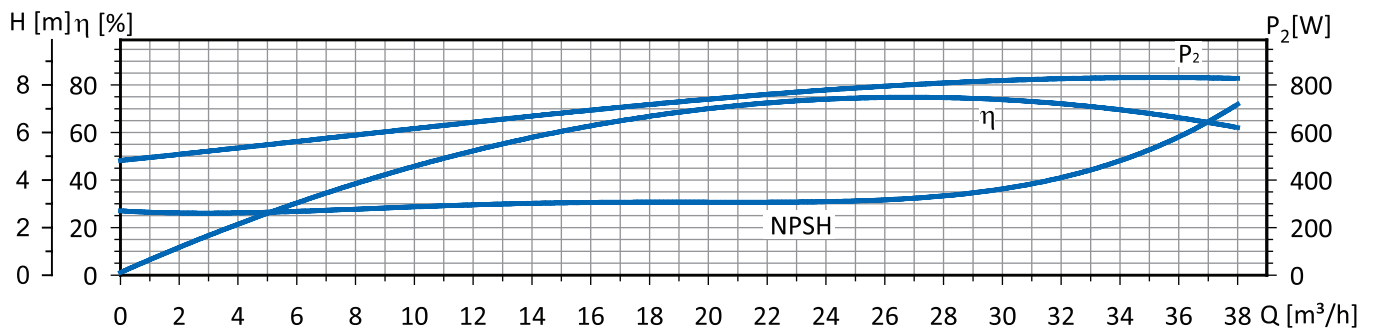
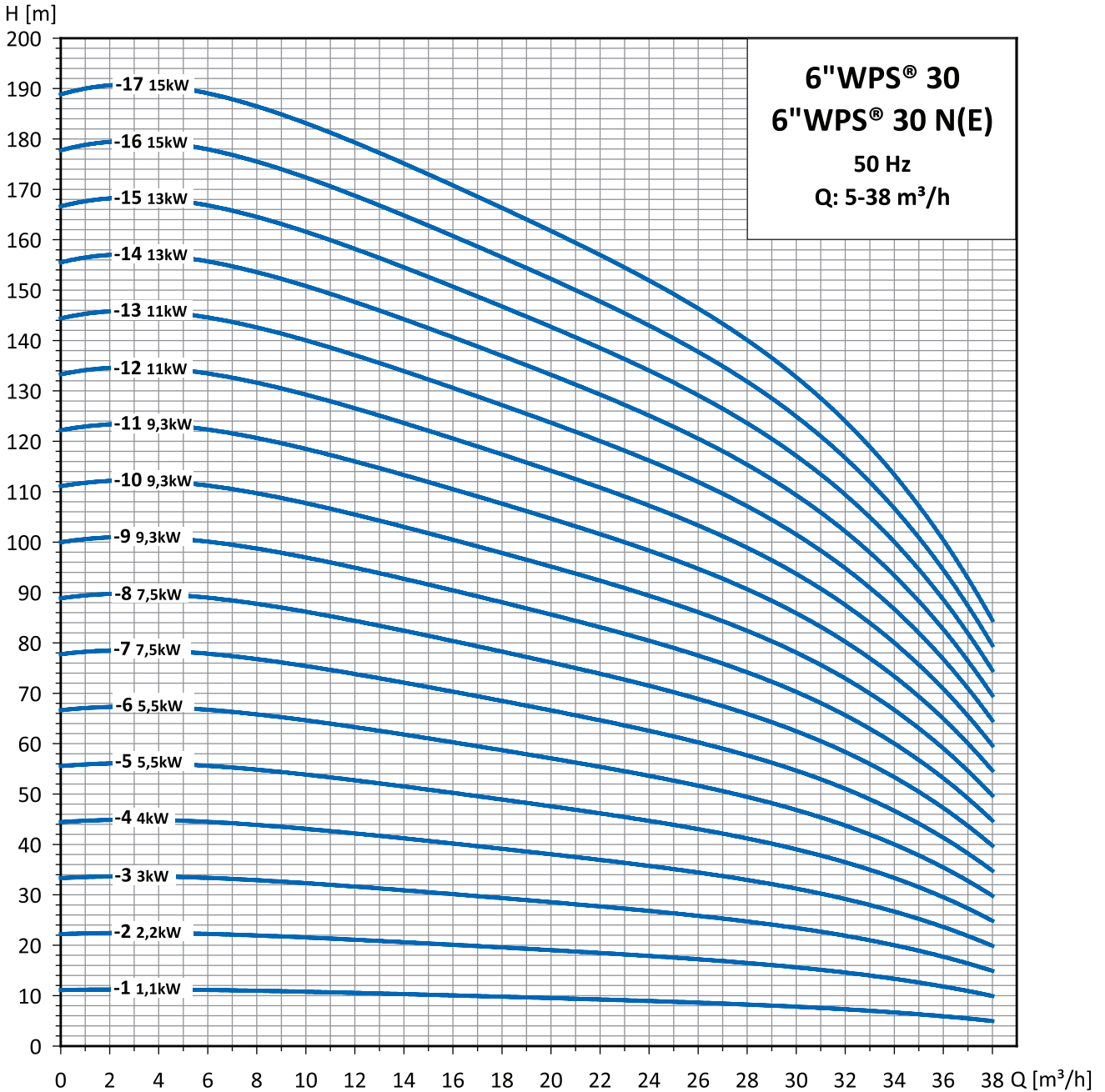

Curves Tolerances according to ISO 9906:2012 Grade 3B

Performance Curves 6"WPS® 30 and 6"WPS® 30 N(E)

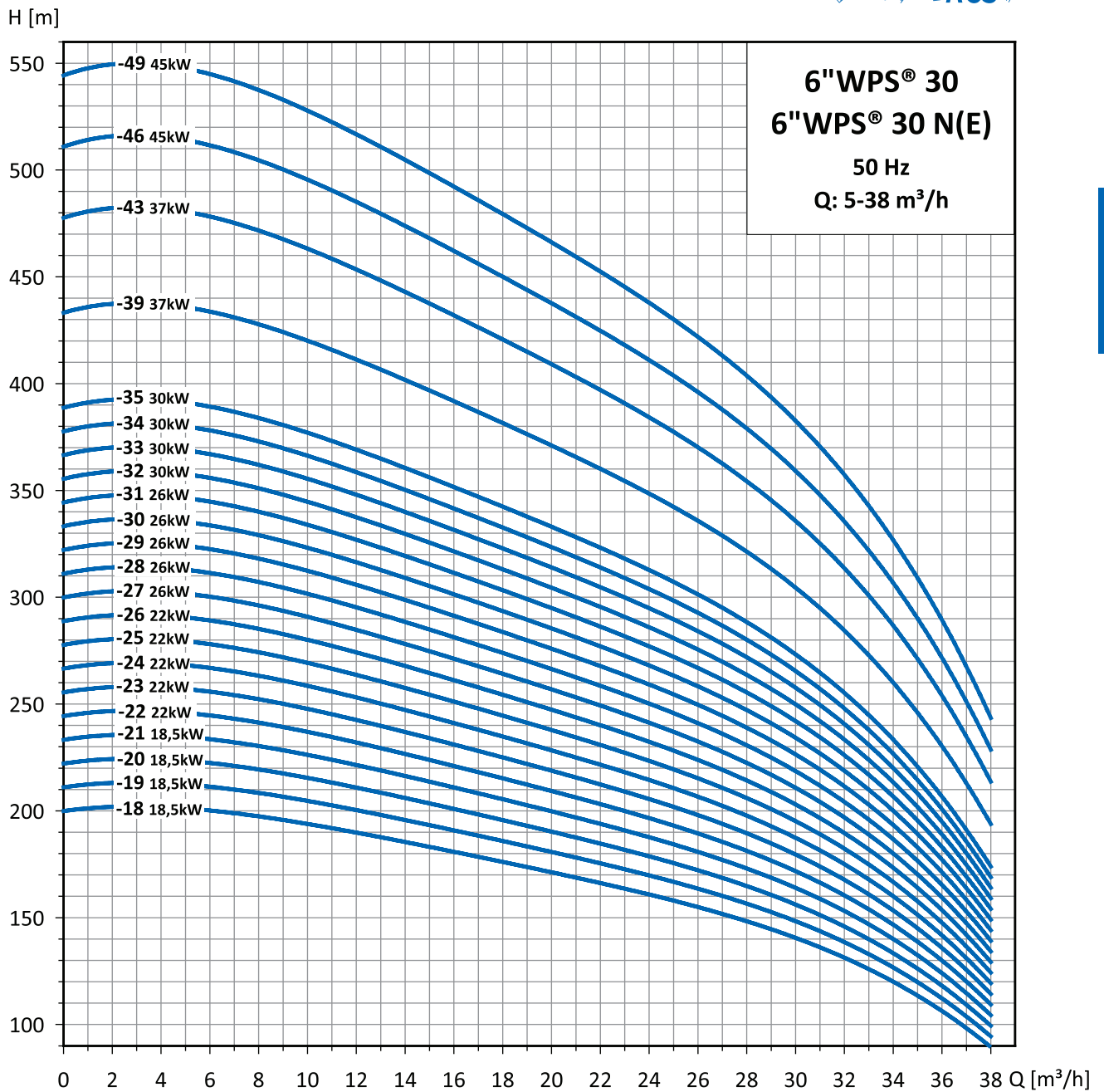

6"WPS®

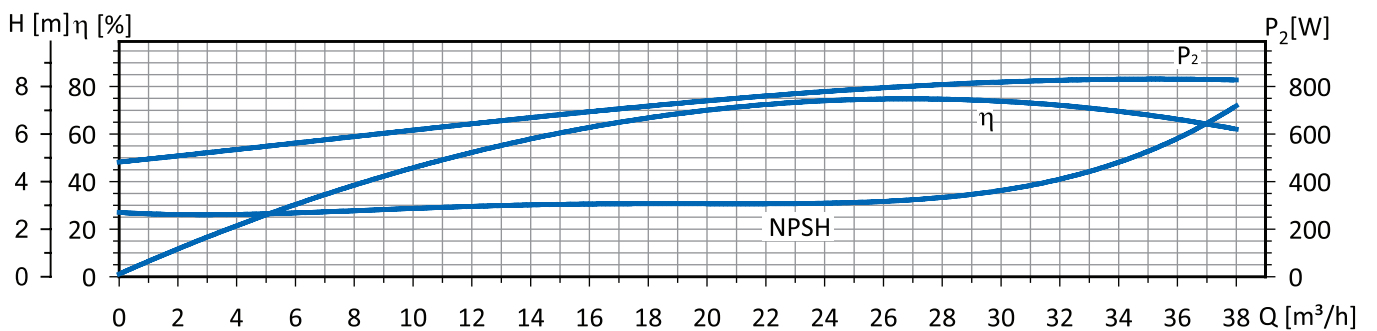

Technical Data

Selection Chart 6"WPS® 30 and 6"WPS® 30 N(E)

6"WPS®

Pump Type	Pump Power P ₂		Flow [m ³ /h]								Full load current	
	[kW]	[HP]	0	8	16	22	26	30	34	38	3x230V	3x400V
6"WPS® 30-1	1,1	1,5	11	11	10	9	9	8	7	5	4,5	2,5
6"WPS® 30-2	2,2	3	22	22	20	18	17	16	13	10	9,0	5,1
6"WPS® 30-3	3	4	33	33	30	28	26	23	20	15	12,4	6,9
6"WPS® 30-4	4	5,5	44	44	40	37	35	31	26	20	15,2	8,4
6"WPS® 30-5	5,5	7,5	56	55	50	46	44	39	33	25	18,7	10,5
6"WPS® 30-6	5,5	7,5	67	66	60	55	52	47	40	30	21,8	12,6
6"WPS® 30-7	7,5	10	78	77	70	64	61	55	46	35	25,1	13,5
6"WPS® 30-8	7,5	10	89	88	80	74	70	63	53	40	27,3	15,5
6"WPS® 30-9	9,3	12,5	100	99	90	83	78	70	59	45	33,2	18,0
6"WPS® 30-10	9,3	12,5	111	110	100	92	87	78	66	50	34,7	19,5
6"WPS® 30-11	9,3	12,5	122	121	110	101	96	86	72	55	36,0	20,7
6"WPS® 30-12	11	15	133	132	120	110	104	94	79	60	38,5	21,3
6"WPS® 30-13	11	15	144	143	130	120	113	102	86	65	40,1	23,3
6"WPS® 30-14	13	17,5	155	154	140	129	122	109	92	70	–	27,6
6"WPS® 30-15	13	17,5	167	165	150	138	131	117	99	75	–	29,3
6"WPS® 30-16	15	20	178	176	160	147	139	125	105	80	51,7	29,6
6"WPS® 30-17	15	20	189	187	170	156	148	133	112	85	54,2	31,3
6"WPS® 30-18	18,5	25	200	198	180	166	157	141	119	90	60,8	33,5
6"WPS® 30-19	18,5	25	211	209	190	175	165	149	125	95	62,1	34,9
6"WPS® 30-20	18,5	25	222	220	200	184	174	156	132	100	69,9	36,7
6"WPS® 30-21	18,5	25	233	231	210	193	183	164	138	105	66,7	38,5
6"WPS® 30-22	22	30	244	242	220	202	191	172	145	110	72,7	39,8
6"WPS® 30-23	22	30	255	253	230	212	200	180	152	115	74,4	41,6
6"WPS® 30-24	22	30	266	264	240	221	209	188	158	120	76,1	43,1
6"WPS® 30-25	22	30	278	275	250	230	218	196	165	125	77,2	44,5
6"WPS® 30-26	22	30	289	286	260	239	226	203	171	130	78,5	45,3
6"WPS® 30-27	26	35	300	297	270	248	235	211	178	135	–	49,7
6"WPS® 30-28	26	35	311	308	280	258	244	219	185	140	–	51,5
6"WPS® 30-29	26	35	322	319	290	267	252	227	191	145	–	52,9
6"WPS® 30-30	26	35	333	330	300	276	261	235	198	150	–	54,3
6"WPS® 30-31	26	35	344	341	310	285	270	242	204	155	–	56,7
6"WPS® 30-32	30	40	355	352	320	294	278	250	211	160	100	56,3
6"WPS® 30-33	30	40	366	363	330	304	287	258	217	165	102	58,1
6"WPS® 30-34	30	40	377	374	340	313	296	266	224	170	104	60,7
6"WPS® 30-35	30	40	389	385	350	322	305	274	231	175	107	63,5
6"WPS® 30-39	37	50	433	429	390	359	339	305	257	195	–	70,0
6"WPS® 30-43	37	50	477	473	430	396	374	336	283	215	–	77,9
6"WPS® 30-46	45	60	511	506	460	423	400	360	303	230	–	84,7
6"WPS® 30-49	45	60	544	539	490	451	426	383	323	245	–	95,2

Dimensions and Weights 6"WPS® 30 and 6"WPS® 30 N(E)

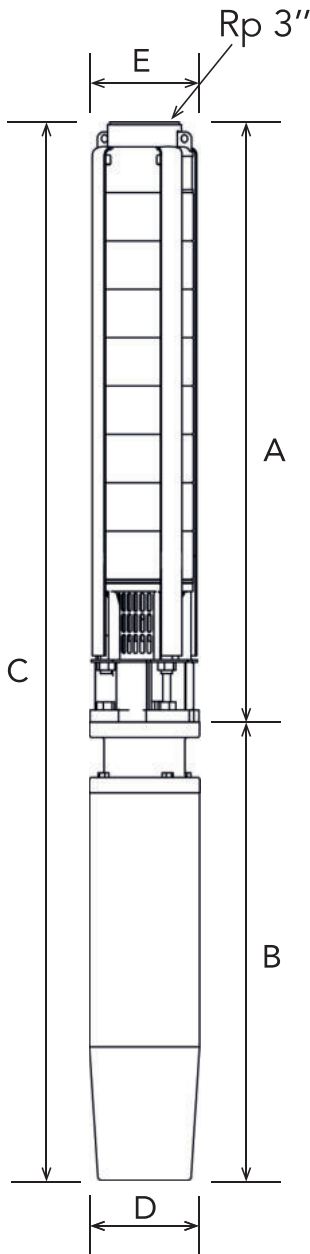

Pump Type	A [mm]	B [mm]	C [mm]	D [mm]	E [mm]	E* [mm]	Motor Type	Weight [kg]	
								Pump end	Electropump
6"WPS® 30-1	368	283	651	95	131	-	4"	7,1	19,6
6"WPS® 30-2	464	339	803	95	131	-	4"	9,0	23,4
6"WPS® 30-3	560	477	1037	95	131	-	4"	10,8	29,7
6"WPS® 30-4	656	543	1199	95	131	-	4"	12,6	34,4
6"WPS® 30-4	662	581	1243	137	140	142	6"	14,1	53,4
6"WPS® 30-5	752	653	1405	95	131	-	4"	14,4	43,1
6"WPS® 30-5	758	614	1372	137	140	142	6"	15,9	58,8
6"WPS® 30-6	848	653	1501	95	131	-	4"	16,2	44,9
6"WPS® 30-6	854	614	1468	137	140	142	6"	7,7	60,6
6"WPS® 30-7	944	730	1674	95	131	-	4"	18,0	50,7
6"WPS® 30-7	950	646	1596	137	140	142	6"	19,5	66,5
6"WPS® 30-8	1040	730	1770	95	131	-	4"	19,8	52,5
6"WPS® 30-8	1046	646	1692	137	140	142	6"	21,4	68,4
6"WPS® 30-9	1142	679	1821	137	140	142	6"	23,2	72,7
6"WPS® 30-10	1238	679	1917	137	140	142	6"	25,0	74,5
6"WPS® 30-11	1334	679	2013	137	140	142	6"	26,8	76,3
6"WPS® 30-12	1430	711	2141	137	140	142	6"	28,6	80,3
6"WPS® 30-13	1526	711	2237	137	140	142	6"	30,4	82,1
6"WPS® 30-14	1622	829	2451	144	145	145	6"	32,2	93,2
6"WPS® 30-15	1718	829	2547	144	145	145	6"	34,0	95,0
6"WPS® 30-16	1814	776	2590	137	140	142	6"	35,8	94,3
6"WPS® 30-17	1910	776	2686	137	140	142	6"	37,7	96,2
6"WPS® 30-18	2006	842	2848	137	140	142	6"	39,5	104,6
6"WPS® 30-19	2102	842	2944	137	140	142	6"	41,3	106,4
6"WPS® 30-20	2198	842	3040	137	140	142	6"	43,1	108,2
6"WPS® 30-21	2294	842	3136	137	140	142	6"	44,9	110,0
6"WPS® 30-22	2390	907	3297	137	140	142	6"	46,7	118,2
6"WPS® 30-23	2486	907	3393	137	140	142	6"	48,5	120,0
6"WPS® 30-24	2582	907	3489	137	140	142	6"	50,3	121,8
6"WPS® 30-25	2678	907	3585	137	140	142	6"	52,2	123,7
6"WPS® 30-26	2774	907	3681	137	140	142	6"	54,0	125,5
6"WPS® 30-27	2870	1114	3984	144	145	145	6"	55,8	145,8
6"WPS® 30-28	2966	1114	4080	144	145	145	6"	57,6	147,6
6"WPS® 30-29	3062	1114	4176	144	140	142	6"	59,4	149,4
6"WPS® 30-30	3158	1114	4272	144	140	142	6"	61,2	151,2
6"WPS® 30-31	3254	1114	4368	144	140	142	6"	63,0	153,0
6"WPS® 30-32	3350	1037	4387	137	140	142	6"	64,8	150,5
6"WPS® 30-33	3446	1037	4483	137	140	142	6"	66,6	152,3
6"WPS® 30-34	3542	1037	4579	137	140	142	6"	68,5	156,2
6"WPS® 30-35	3638	1037	4675	137	140	142	6"	70,3	156,0
6"WPS® 30-39	4022	1421	5443	144	173	176	6"	127,8	260,8
6"WPS® 30-43	4406	1421	5827	144	173	176	6"	139,8	272,8
6"WPS® 30-46	4694	1574	6268	137	173	176	6"	148,9	295,9
6"WPS® 30-49	4982	1574	6556	137	173	176	6"	157,9	304,9

* With 2 cable guards

Performance Curves

Performance Curves 6" WPS® 45 and 6" WPS® 45 N(E)



6" WPS®

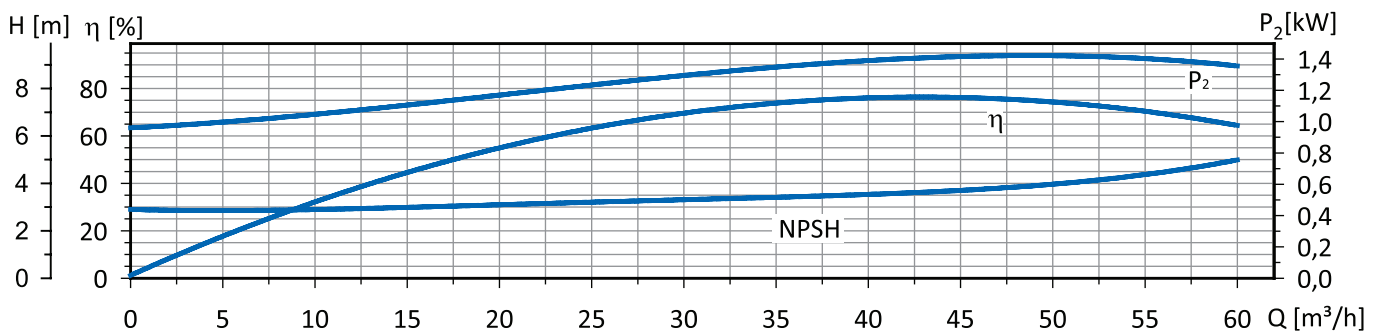
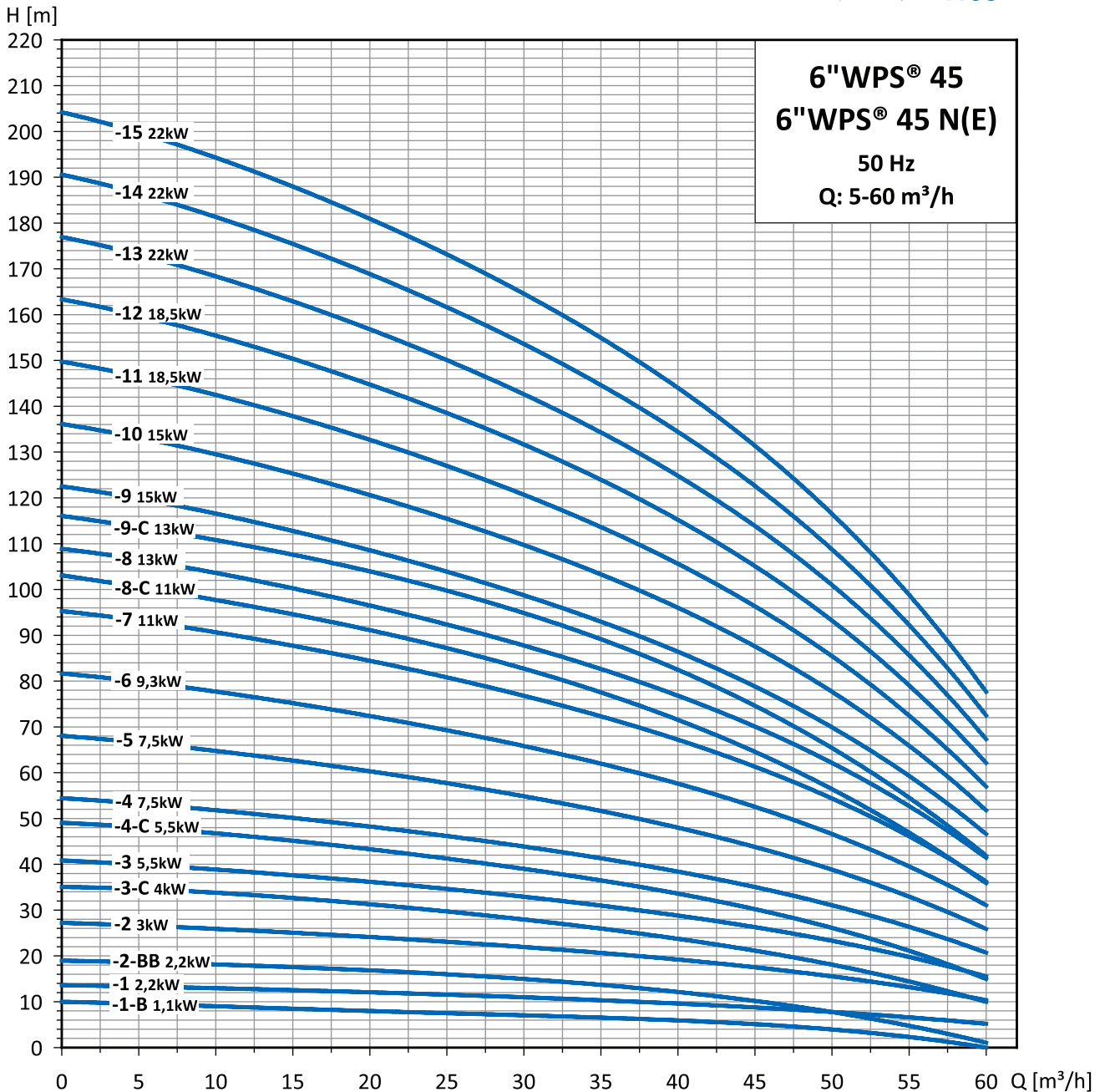

Curves Tolerances according to ISO 9906:2012 Grade 3B

Performance Curves 6"WPS® 45 and 6"WPS® 45 N(E)

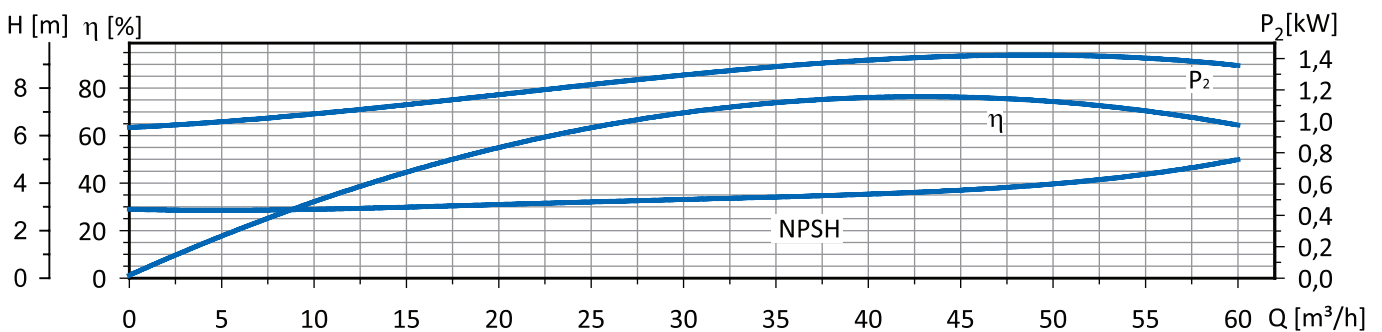
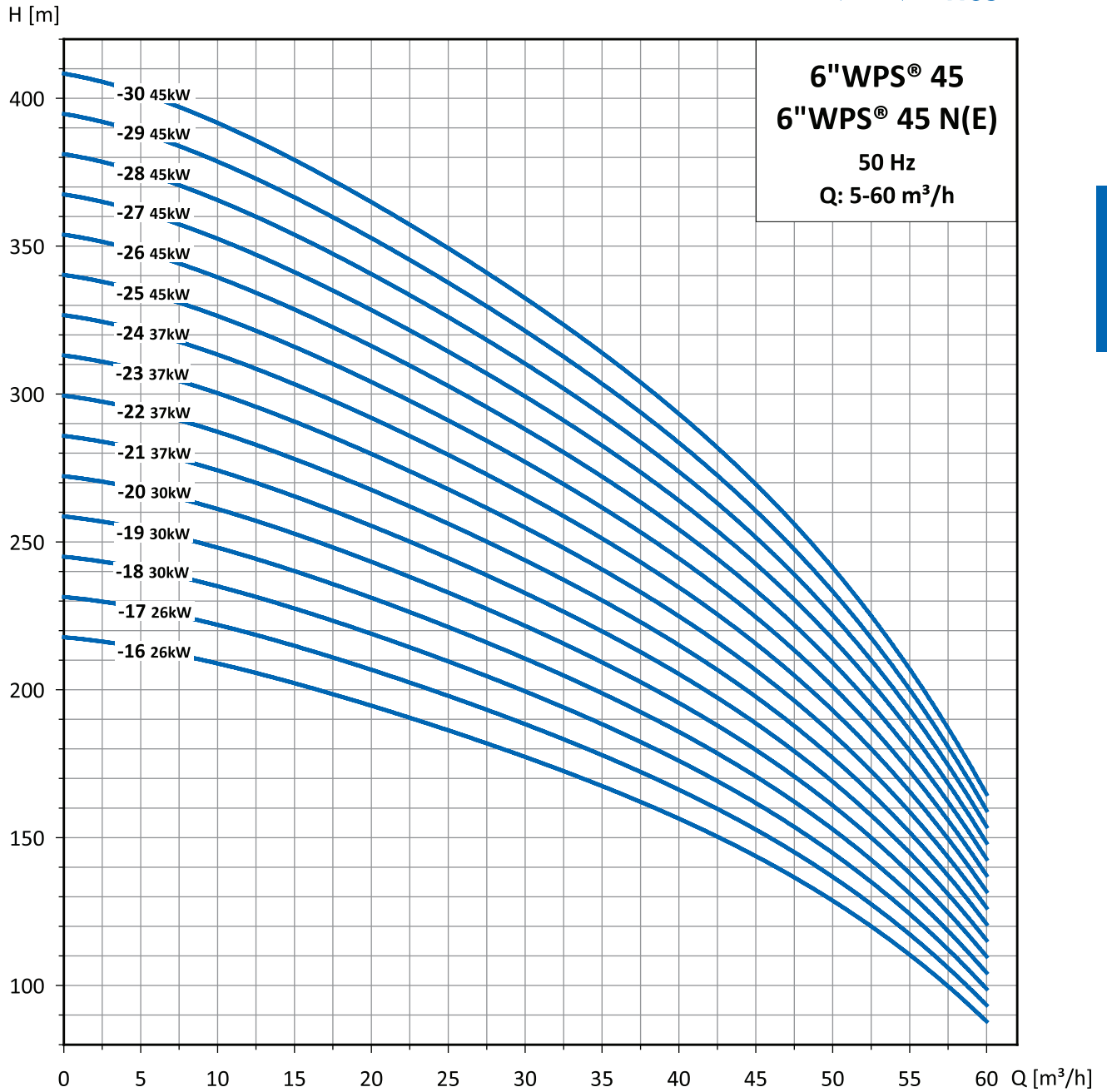

Technical Data

Selection Chart 6"WPS® 45 and 6"WPS® 45 N(E)

6"WPS®

Pump Type	Pump Power P ₂		Flow [m ³ /h]								Full load current	
	[kW]	[HP]	0	10	20	30	40	45	50	60	3x230V	3x400V
6"WPS® 45-1-B	1,1	1,5	10	9	8	7	6	5	4	0	4,9	2,8
6"WPS® 45-1	2,2	3	14	13	12	11	10	9	8	5	7,3	3,4
6"WPS® 45-2-BB	2,2	3	19	18	17	15	12	10	8	1	9,5	5,5
6"WPS® 45-2	3	4	27	26	24	22	19	18	15	10	12,9	7,4
6"WPS® 45-3-C	4	5,5	35	34	31	28	24	21	18	10	16,0	9,3
6"WPS® 45-3	5,5	7,5	41	39	36	33	29	27	23	16	18,9	10,7
6"WPS® 45-4-C	5,5	7,5	49	47	43	39	34	30	26	15	21,7	12,5
6"WPS® 45-4	7,5	10	54	52	48	44	38	36	30	21	24,1	13,2
6"WPS® 45-5	7,5	10	68	65	60	55	48	45	38	26	27,6	15,9
6"WPS® 45-6	9,3	12,5	82	78	72	66	57	54	46	31	36,0	20,5
6"WPS® 45-7	11	15	95	91	84	77	67	63	53	36	38,8	22,1
6"WPS® 45-8-C	11	15	103	98	91	82	73	64	56	36	40,4	23,3
6"WPS® 45-8	13	17,5	109	104	96	88	76	72	61	42	-	27,1
6"WPS® 45-9-C	13	17,5	116	111	104	94	84	74	65	42	-	29,6
6"WPS® 45-9	15	20	122	117	108	99	86	81	68	47	50,7	27,2
6"WPS® 45-10	15	20	136	130	120	110	95	90	76	52	54,2	31,3
6"WPS® 45-11	18,5	25	150	143	132	121	105	99	84	57	62,9	34,2
6"WPS® 45-12	18,5	25	163	156	144	132	114	108	91	62	66,7	38,5
6"WPS® 45-13	22	30	177	169	156	143	124	117	99	68	74,1	40,3
6"WPS® 45-14	22	30	190	182	168	154	133	126	106	73	75,7	42,8
6"WPS® 45-15	22	30	204	195	180	165	143	135	114	78	78,5	45,5
6"WPS® 45-16	26	35	218	210	194	178	157	144	128	88	-	51,4
6"WPS® 45-17	26	35	231	223	206	189	167	153	136	94	-	56,7
6"WPS® 45-18	30	40	245	236	218	200	176	162	144	99	100	56,3
6"WPS® 45-19	30	40	258	249	230	211	186	171	152	105	104	59,4
6"WPS® 45-20	30	40	272	262	242	222	196	180	160	110	107	63,5
6"WPS® 45-21	37	50	286	275	254	233	206	189	168	116	-	67,2
6"WPS® 45-22	37	50	299	288	266	244	216	198	176	121	-	69,9
6"WPS® 45-23	37	50	313	301	278	255	225	207	184	127	-	73,5
6"WPS® 45-24	37	50	326	314	290	266	235	216	192	132	-	77,9
6"WPS® 45-25	45	60	340	328	303	278	245	225	200	138	-	79,6
6"WPS® 45-26	45	60	354	341	315	289	255	234	208	143	-	81,7
6"WPS® 45-27	45	60	367	354	327	300	265	243	216	149	-	84,0
6"WPS® 45-28	45	60	381	367	339	311	274	252	224	154	-	87,5
6"WPS® 45-29	45	60	394	380	351	322	284	261	232	160	-	91,3
6"WPS® 45-30	45	60	408	393	363	333	294	270	240	165	-	95,2

Dimensions and Weights 6"WPS® 45 and 6"WPS® 45 N(E)

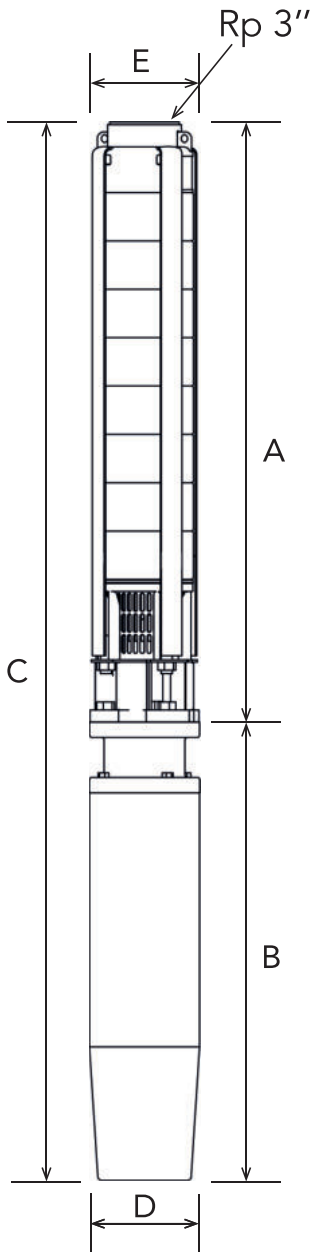

Pump Type	A [mm]	B [mm]	C [mm]	D [mm]	E [mm]	E* [mm]	Motor Type	Weight [kg]	
								Pump end	Electropump
6"WPS® 45-1-B	385	283	668	95	147	-	4"	9,6	21,1
6"WPS® 45-1	385	339	724	95	147	-	4"	9,6	24,0
6"WPS® 45-2-BB	498	339	837	95	147	-	4"	10,2	24,6
6"WPS® 45-2	498	477	975	95	147	-	4"	10,2	29,1
6"WPS® 45-3-C	611	543	1154	95	147	-	4"	12,5	34,3
6"WPS® 45-3-C	614	581	1195	136	147	150	6"	14,0	53,3
6"WPS® 45-3	611	581	1192	95	147	-	4"	12,5	41,2
6"WPS® 45-3	614	653	1267	136	147	150	6"	14,0	56,9
6"WPS® 45-4-C	724	581	1305	95	147	-	4"	14,8	43,5
6"WPS® 45-4-C	727	653	1380	136	147	150	6"	16,3	59,2
6"WPS® 45-4	724	730	1454	95	147	-	4"	14,8	47,5
6"WPS® 45-4	727	646	1373	136	147	150	6"	16,3	63,3
6"WPS® 45-5	837	730	1567	95	147	-	4"	17,1	49,8
6"WPS® 45-5	840	646	1486	136	147	150	6"	18,6	65,6
6"WPS® 45-6	953	679	1632	136	147	150	6"	21,0	70,5
6"WPS® 45-7	1066	711	1777	136	147	150	6"	23,3	75,0
6"WPS® 45-8-C	1179	711	1890	136	147	150	6"	25,6	77,3
6"WPS® 45-8	1179	829	2008	144	147	150	6"	25,6	86,6
6"WPS® 45-9-C	1292	829	2121	144	147	150	6"	27,9	88,9
6"WPS® 45-9	1292	776	2068	136	147	150	6"	27,9	86,4
6"WPS® 45-10	1405	776	2181	136	147	150	6"	30,3	88,8
6"WPS® 45-11	1518	842	2360	136	147	150	6"	32,6	97,7
6"WPS® 45-12	1631	842	2473	136	147	150	6"	34,9	100,0
6"WPS® 45-13	1744	907	2651	136	147	150	6"	37,2	108,7
6"WPS® 45-14	1857	907	2764	136	147	150	6"	39,6	111,1
6"WPS® 45-15	1970	907	2877	136	147	150	6"	41,9	113,4
6"WPS® 45-16	2083	1114	3197	144	147	150	6"	44,2	134,2
6"WPS® 45-17	2196	1114	3310	144	147	150	6"	46,5	136,5
6"WPS® 45-18	2309	1037	3346	136	147	150	6"	48,9	134,6
6"WPS® 45-19	2422	1037	3459	136	147	150	6"	51,2	136,9
6"WPS® 45-20	2535	1037	3572	136	147	150	6"	53,5	139,2
6"WPS® 45-21	2648	1421	4069	144	147	150	6"	55,8	188,8
6"WPS® 45-22	2761	1421	4182	144	147	150	6"	58,2	191,2
6"WPS® 45-23	2874	1421	4295	144	147	150	6"	60,5	193,5
6"WPS® 45-24	2987	1421	4408	144	147	150	6"	62,8	195,8
6"WPS® 45-25	3100	1574	4674	136	147	150	6"	65,1	212,1
6"WPS® 45-26	3213	1574	4787	136	147	150	6"	67,5	214,5
6"WPS® 45-27	3326	1574	4900	136	147	150	6"	69,8	216,8
6"WPS® 45-28	3439	1574	5013	136	147	150	6"	72,1	219,1
6"WPS® 45-29	3552	1574	5126	136	147	150	6"	74,4	221,4
6"WPS® 45-30	3665	1574	5239	136	147	150	6"	76,8	223,8

6"WPS®

* With 2 cable guards

Performance Curves

Performance Curves 6"WPS® 60 and 6"WPS® 60 N(E)



6"WPS®

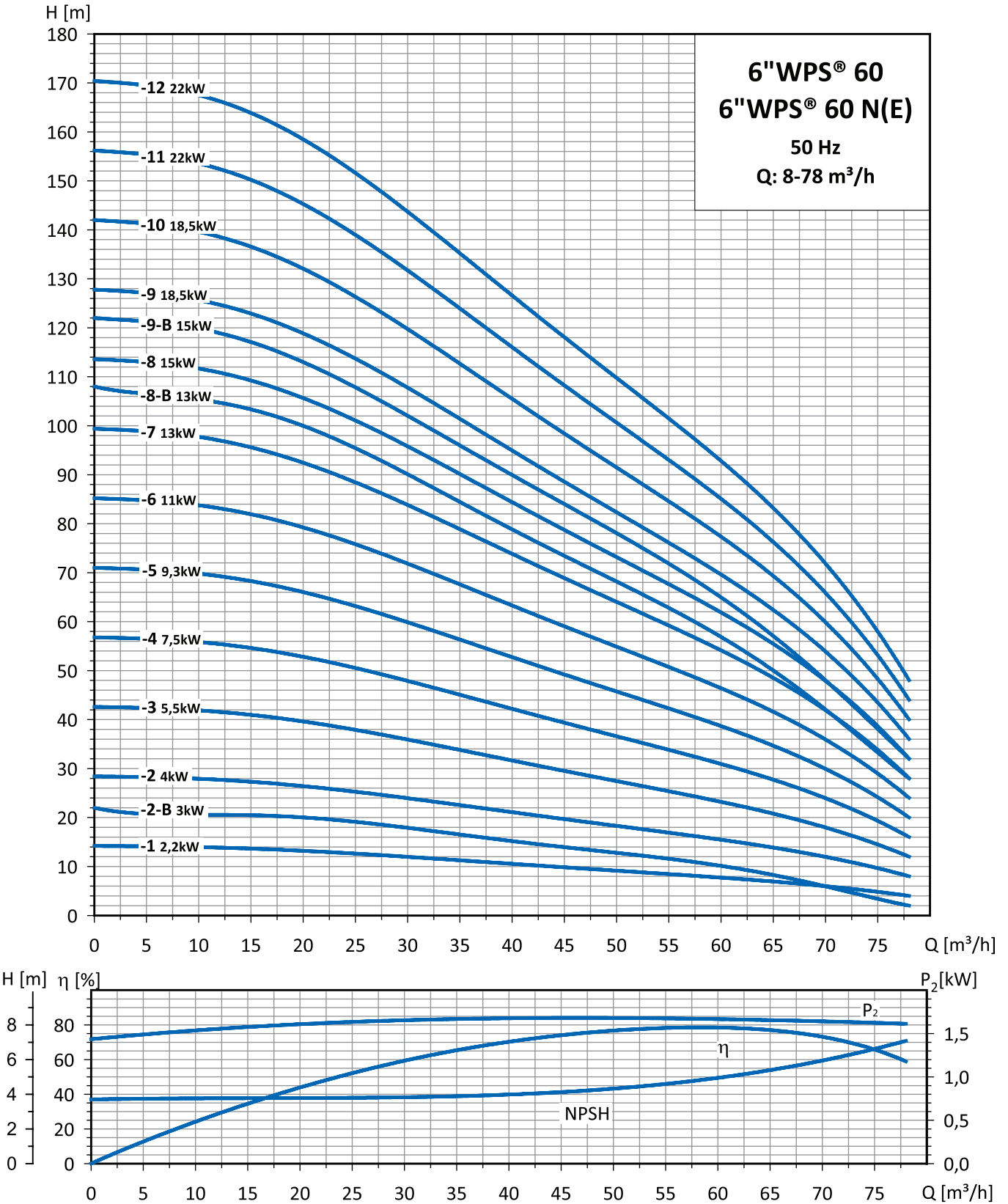

Performance Curves 6"WPS® 60 and 6"WPS® 60 N(E)

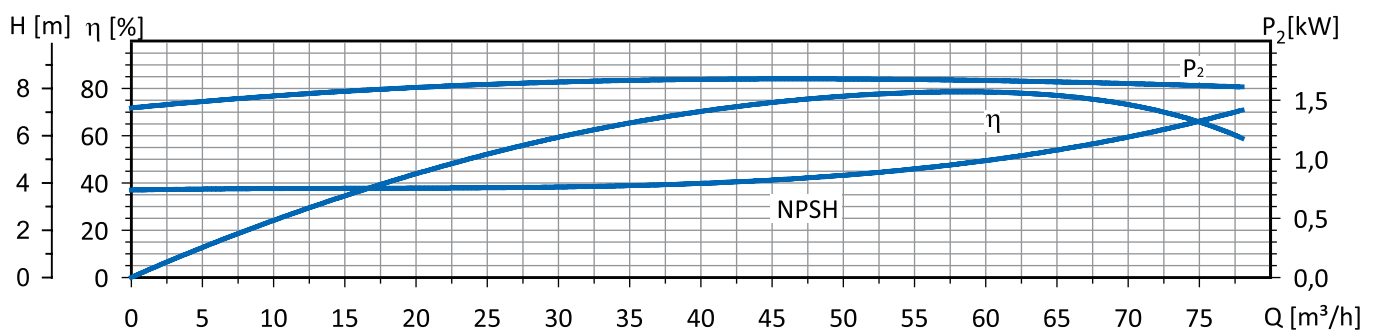
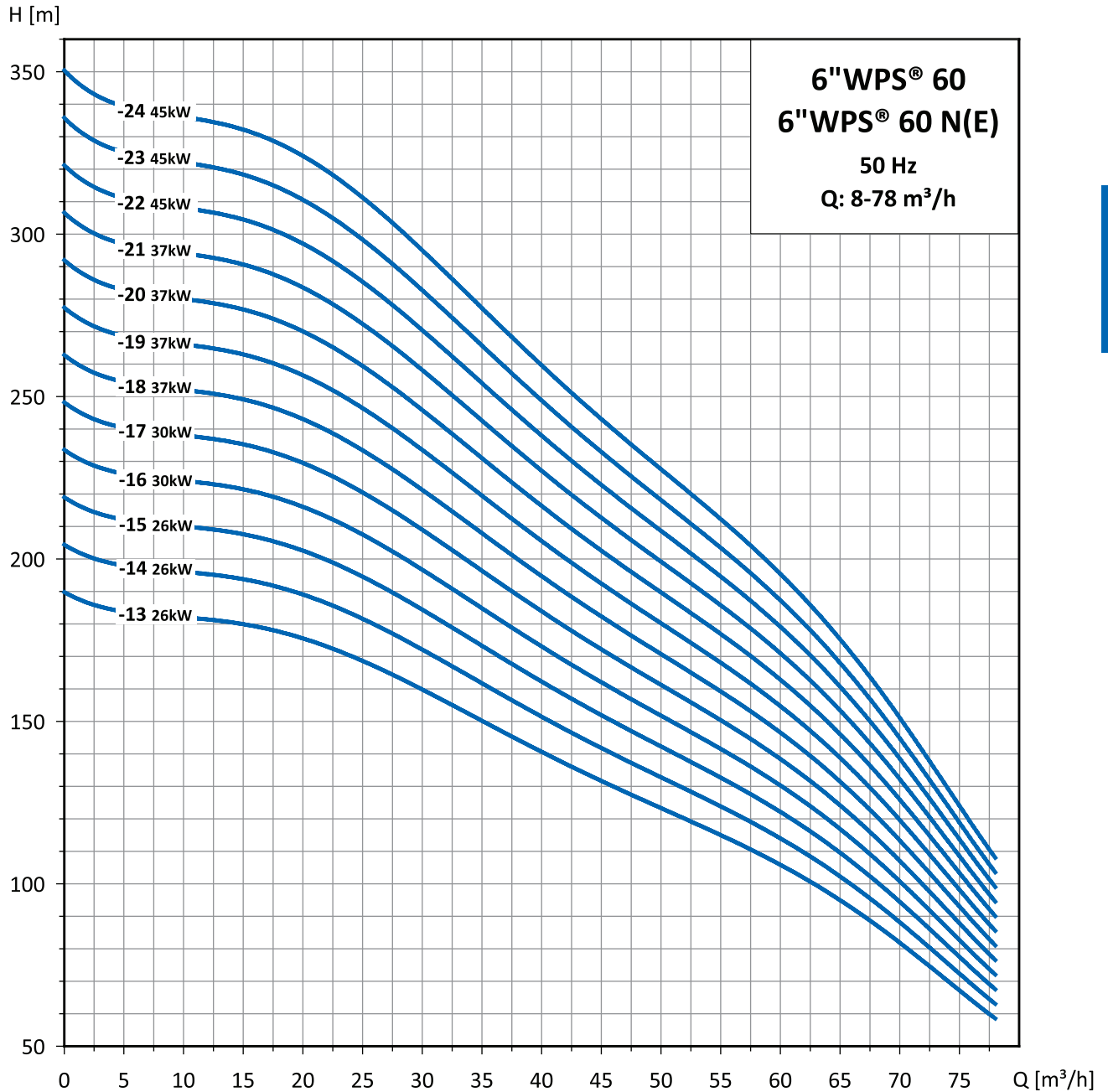

Technical Data



Selection Chart 6"WPS® 60 and 6"WPS® 60 N(E)

Pump Type	Pump Power P ₂		Flow [m ³ /h]								Full load current	
	[kW]	[HP]	0	20	30	40	50	60	70	78	3x230V	3x400V
6"WPS® 60-1	2,2	3	14	13	12	11	9	8	6	4	9,0	5,1
6"WPS® 60- 2-B	3	4	22	20	18	15	13	10	6	2	13,0	7,5
6"WPS® 60-2	4	5,5	28	26	24	21	18	15	12	8	15,5	9,0
6"WPS® 60-3	5,5	7,5	43	40	36	32	28	23	18	13	20,9	11,9
6"WPS® 60-4	7,5	10	57	53	48	42	37	31	24	17	27,7	16,0
6"WPS® 60-5	9,3	12,5	71	66	60	53	46	39	30	21	35,1	20,3
6"WPS® 60-6	11	15	85	79	72	63	55	46	36	25	40,2	23,1
6"WPS® 60-7	13	17,5	99	92	84	74	64	54	42	29	-	27,0
6"WPS® 60- 8-B	13	17,5	108	100	90	79	68	57	42	26	-	29,6
6"WPS® 60-8	15	20	114	106	96	84	74	62	48	34	52,9	29,9
6"WPS® 60- 9-B	15	20	122	113	102	90	78	65	48	30	54,2	31,3
6"WPS® 60-9	18,5	25	128	119	108	95	83	69	54	38	63,5	38,8
6"WPS® 60-10	18,5	25	142	132	120	105	92	77	60	42	66,1	37,6
6"WPS® 60-11	22	30	156	145	132	116	101	85	66	46	76,9	40,0
6"WPS® 60-12	22	30	170	158	144	126	110	92	72	50	78,3	45,1
6"WPS® 60-13	26	35	190	176	160	140	124	106	82	59	-	49,6
6"WPS® 60-14	26	35	204	189	172	151	133	114	88	63	-	52,5
6"WPS® 60-15	26	35	219	203	185	162	143	122	95	68	-	56,7
6"WPS® 60-16	30	40	234	216	197	173	152	130	101	72	102	58,3
6"WPS® 60-17	30	40	248	230	209	184	162	138	107	77	107	63,5
6"WPS® 60-18	37	50	263	243	221	194	171	146	113	81	-	68,2
6"WPS® 60-19	37	50	277	257	234	205	181	154	120	86	-	70,6
6"WPS® 60-20	37	50	292	270	246	216	190	163	126	90	-	73,3
6"WPS® 60-21	37	50	307	284	258	227	200	171	132	95	-	77,9
6"WPS® 60-22	45	60	321	297	271	238	209	179	139	99	-	81,8
6"WPS® 60-23	45	60	336	311	283	248	219	187	145	104	-	87,7
6"WPS® 60-24	45	60	350	324	295	259	228	195	151	108	-	95,2

6"WPS®

Dimensions and Weights 6"WPS® 60 and 6"WPS® 60 N(E)

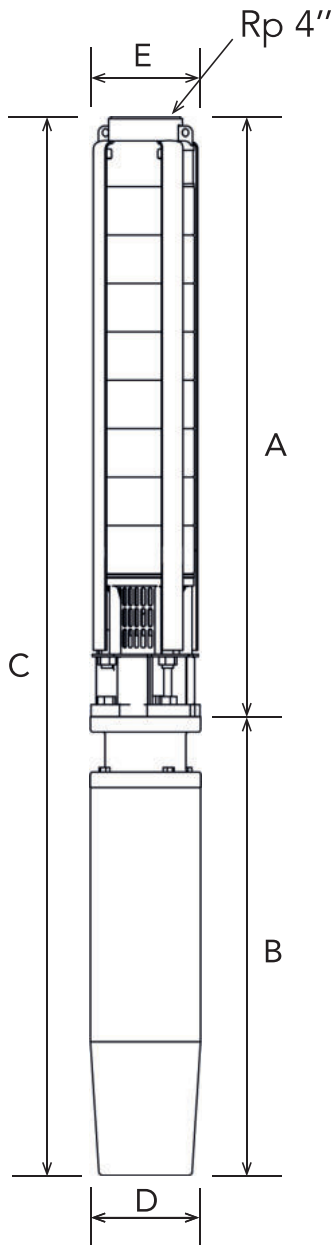

Pump Type	A [mm]	B [mm]	C [mm]	D [mm]	E [mm]	E* [mm]	Motor Type	Weight [kg]	
								Pump end	Electro-pump
6"WPS® 60-1	385	339	724	95	147	-	4"	7,6	22,0
6"WPS® 60- 2-B	498	477	975	95	147	-	4"	10,2	29,1
6"WPS® 60-2	498	543	1041	95	147	-	4"	10,2	32,0
6"WPS® 60-2	501	581	1082	136	147	150	6"	11,7	51,0
6"WPS® 60-3	611	653	1264	95	147	-	4"	12,5	41,2
6"WPS® 60-3	614	614	1228	136	147	150	6"	14,0	56,9
6"WPS® 60-4	724	730	1454	95	147	-	4"	14,8	47,5
6"WPS® 60-4	727	646	1373	136	147	150	6"	16,3	63,3
6"WPS® 60-5	840	679	1519	136	147	150	6"	18,6	68,1
6"WPS® 60-6	953	711	1664	136	147	150	6"	21,0	72,7
6"WPS® 60-7	1066	829	1895	144	147	150	6"	23,3	84,3
6"WPS® 60- 8-B	1179	829	2008	144	147	150	6"	25,6	86,6
6"WPS® 60-8	1179	776	1955	136	147	150	6"	25,6	84,1
6"WPS® 60- 9-B	1292	776	2068	136	147	150	6"	27,9	86,4
6"WPS® 60-9	1292	842	2134	136	147	150	6"	27,9	93,0
6"WPS® 60-10	1405	842	2247	136	147	150	6"	30,3	95,4
6"WPS® 60-11	1518	907	2425	136	147	150	6"	32,6	104,1
6"WPS® 60-12	1631	907	2538	136	147	150	6"	34,9	106,4
6"WPS® 60-13	1744	1114	2858	144	147	150	6"	37,2	127,2
6"WPS® 60-14	1857	1114	2971	144	147	150	6"	39,6	129,6
6"WPS® 60-15	1970	1114	3084	144	147	150	6"	41,9	131,9
6"WPS® 60-16	2083	1037	3120	136	147	150	6"	44,2	129,9
6"WPS® 60-17	2196	1037	3233	136	147	150	6"	46,5	132,2
6"WPS® 60-18	2309	1421	3730	144	147	150	6"	48,9	181,9
6"WPS® 60-19	2422	1421	3843	144	147	150	6"	51,2	184,2
6"WPS® 60-20	2535	1421	3956	144	147	150	6"	53,5	186,5
6"WPS® 60-21	2648	1421	4069	144	147	150	6"	55,8	188,8
6"WPS® 60-22	2761	1574	4335	136	147	150	6"	58,2	205,2
6"WPS® 60-23	2874	1574	4448	136	147	150	6"	60,5	207,5
6"WPS® 60-24	2987	1574	4567	136	147	150	6"	62,8	209,8

* With 2 cable guards

Performance Curves

Performance Curves 6"WPS® 75 and 6"WPS® 75 N



6"WPS®

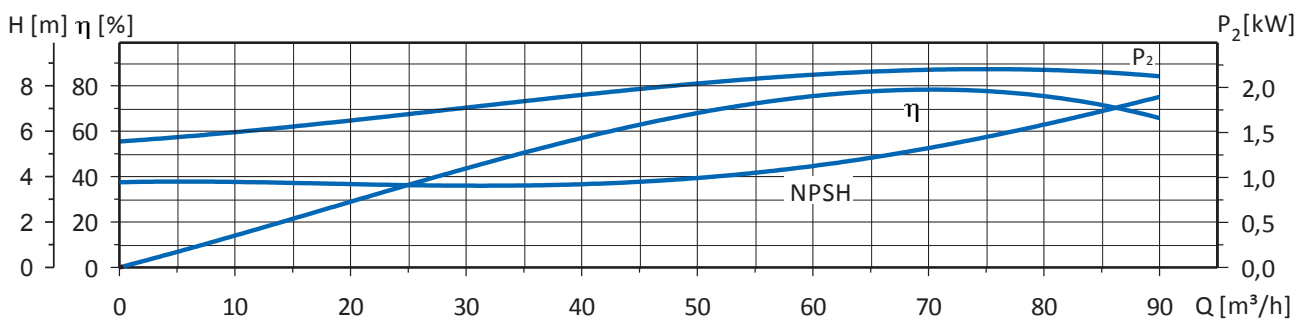
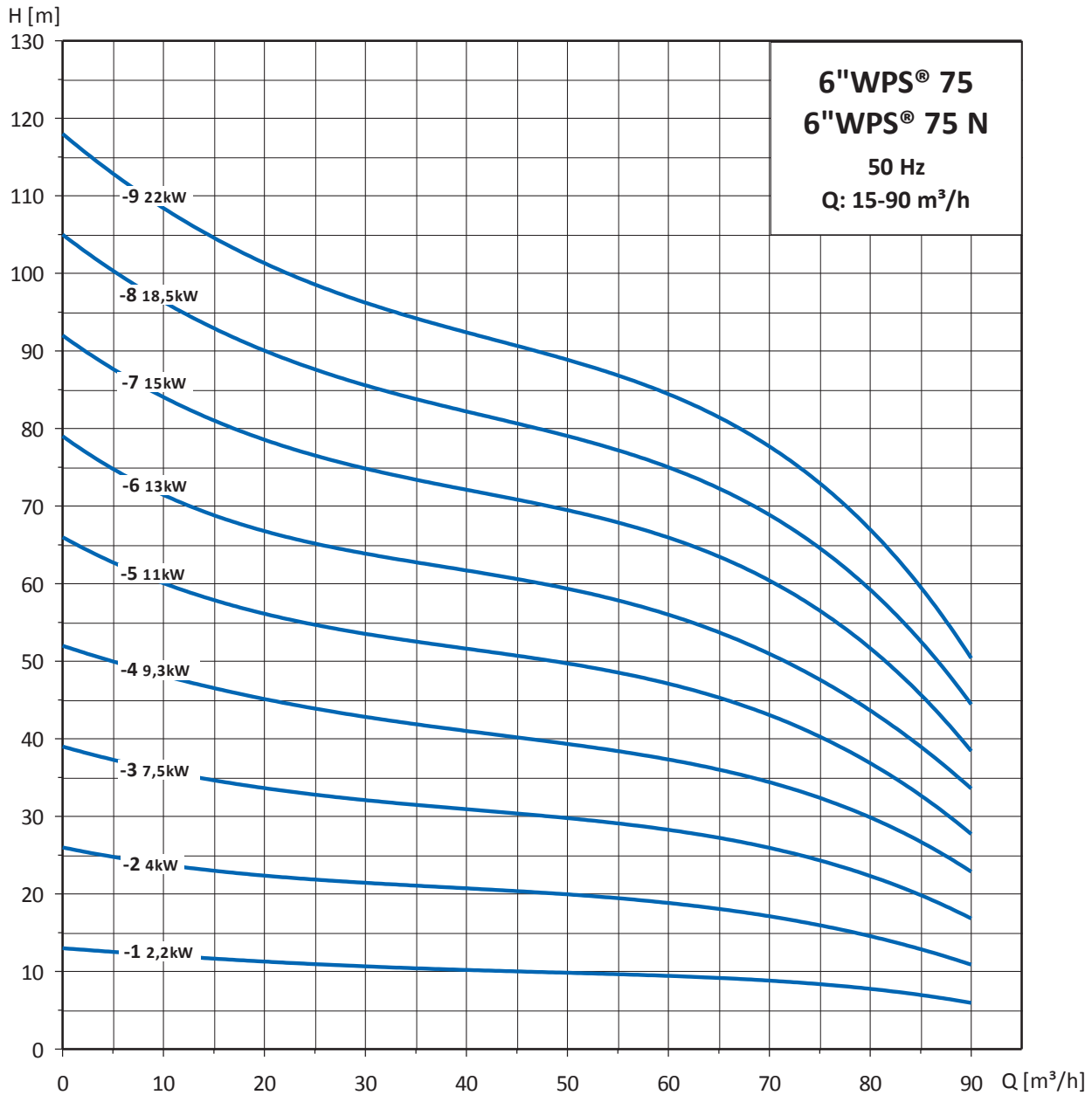

Performance Curves 6"WPS® 75 and 6"WPS® 75 N

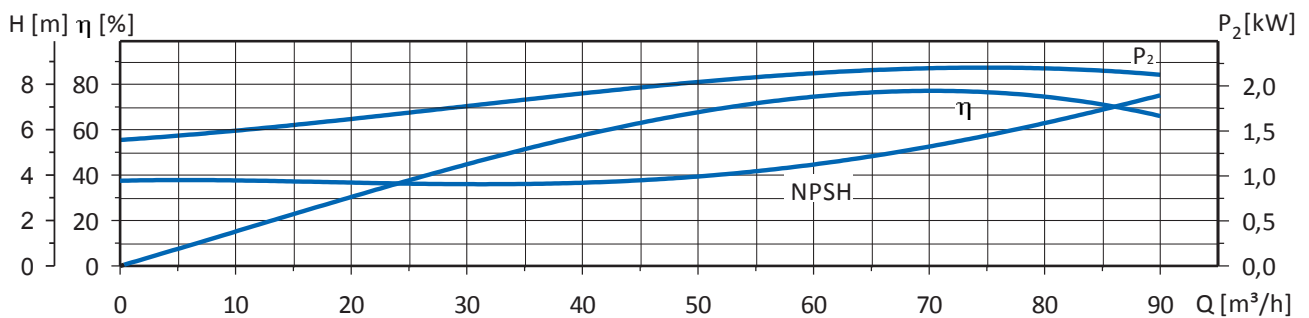
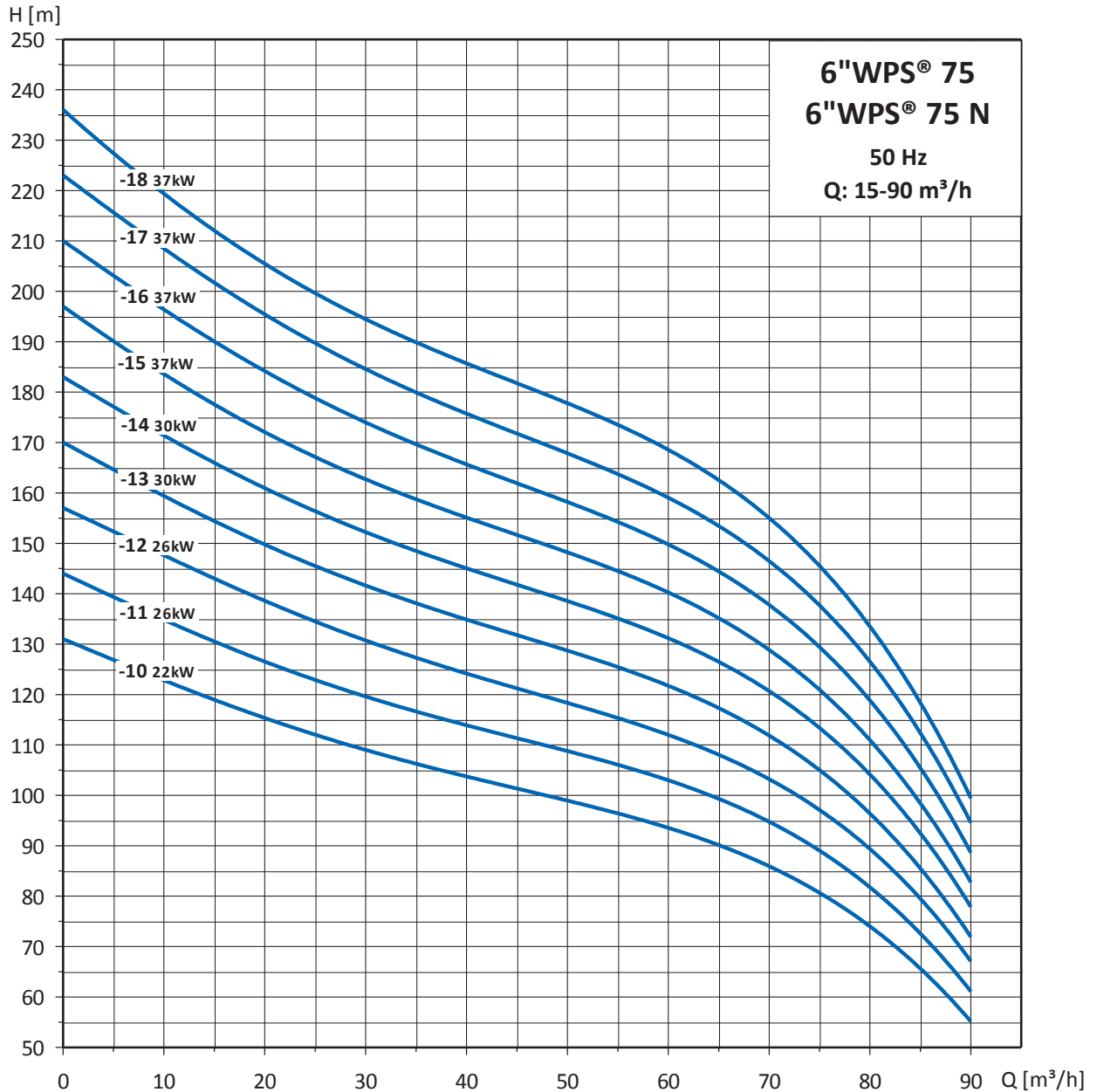

Technical Data

Selection Chart 6"WPS® 75 and 6"WPS® 75 N

Pump Type	Pump Power P ₂		Flow [m ³ /h]								Full load current
	[kW]	[HP]	0	20	40	50	60	70	80	90	3x400V
6"WPS® 75-1	2,2	3	13	11	10	10	9	9	7	6	5,5
6"WPS® 75-2	4	5,5	26	22	21	20	19	17	14	11	9,3
6"WPS® 75-3	7,5	10	39	33	31	30	28	26	22	17	15,0
6"WPS® 75-4	9,3	12,5	52	44	42	40	37	35	29	23	20,5
6"WPS® 75-5	11	15	66	56	52	50	47	44	36	28	23,3
6"WPS® 75-6	13	18,5	79	67	62	60	56	52	43	34	27,1
6"WPS® 75-7	15	20	92	78	73	70	66	61	51	39	31,3
6"WPS® 75-8	18,5	25	105	89	83	80	75	70	58	45	38,5
6"WPS® 75-9	22	30	118	100	94	90	84	78	65	51	45,5
6"WPS® 75-10	22	30	131	111	104	99	94	87	72	56	45,5
6"WPS® 75-11	26	35	144	122	114	109	103	96	79	62	51,4
6"WPS® 75-12	26	35	157	133	125	119	112	105	87	68	51,4
6"WPS® 75-13	30	40	170	144	135	129	122	113	94	73	56,3
6"WPS® 75-14	30	40	183	156	146	139	131	122	101	79	56,3
6"WPS® 75-15	37	50	197	167	156	149	140	131	108	84	77,9
6"WPS® 75-16	37	50	210	178	166	159	150	140	116	90	77,9
6"WPS® 75-17	37	50	223	189	177	169	159	148	123	96	77,9
6"WPS® 75-18	37	50	236	200	187	179	168	157	130	101	77,9

6"WPS®

Dimensions and Weights 6"WPS® 75 and 6"WPS® 75 N

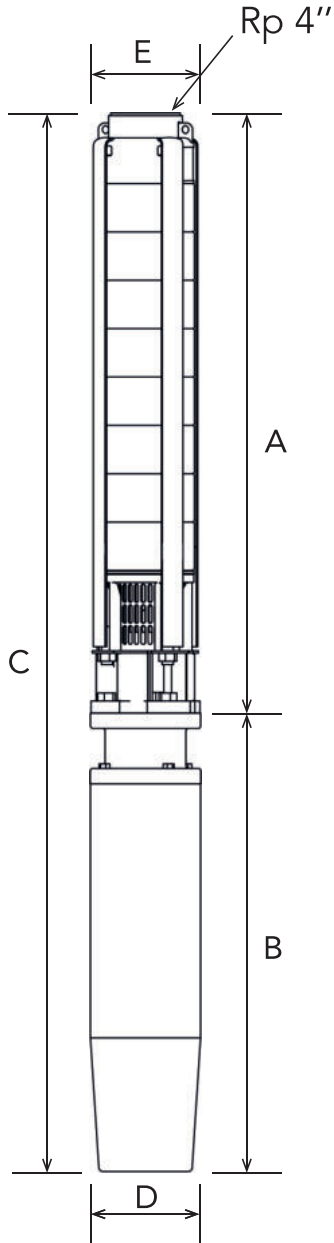

Pump Type	A [mm]	B [mm]	C [mm]	D [mm]	E [mm]	E* [mm]	Motor Type	Weight [kg]	
								Pump end	Electro-pump
6"WPS® 75-1	400	339	739	95	145	150	4"	12,0	26,4
6"WPS® 75-2	507	543	1050	95	145	150	4"	15,0	36,8
6"WPS® 75-2	507	581	1088	139	145	150	6"	15,0	56,3
6"WPS® 75-3	614	730	1344	95	145	150	4"	19,0	51,7
6"WPS® 75-3	614	646	1260	139	145	150	6"	19,0	68,0
6"WPS® 75-4	721	679	1400	139	145	150	6"	23,0	74,3
6"WPS® 75-5	828	711	1539	139	145	150	6"	27,0	81,7
6"WPS® 75-6	932	829	1761	139	145	150	6"	32,0	93,0
6"WPS® 75-7	1042	776	1818	139	145	150	6"	36,0	96,5
6"WPS® 75-8	1149	842	1991	139	145	150	6"	40,0	107,1
6"WPS® 75-9	1256	907	2163	139	145	150	6"	44,0	117,1
6"WPS® 75-10	1363	907	2270	139	145	150	6"	48,0	121,1
6"WPS® 75-11	1470	1114	2584	139	145	150	6"	53,0	143,0
6"WPS® 75-12	1577	1114	2691	139	145	150	6"	57,0	147,0
6"WPS® 75-13	1684	1037	2721	139	145	150	6"	61,0	148,7
6"WPS® 75-14	1791	1037	2828	139	145	150	6"	65,0	152,7
6"WPS® 75-15	1998	1421	3419	139	145	150	6"	70,0	210,0
6"WPS® 75-16	2005	1421	3426	139	145	150	6"	75,0	215,0
6"WPS® 75-17	2112	1421	3533	139	145	150	6"	80,0	220,0
6"WPS® 75-18	2219	1421	3640	139	145	150	6"	85,0	225,0

* With 2 cable guards

Technical Data

Material specification

6" WPS®

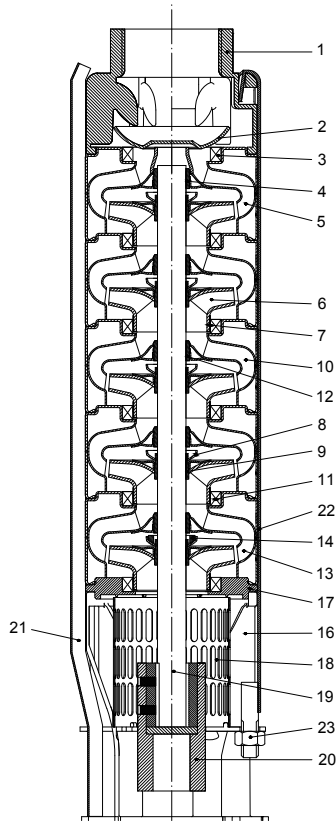

6" WPS® 16

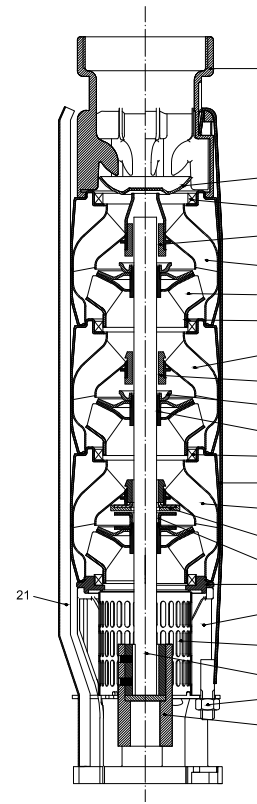

6" WPS® 30
6" WPS® 45
6" WPS® 60
6" WPS® 75

Pos.	Component	Material	6" WPS® Material Code	6" WPS® N Material Code	6" WPS® NE Material Code
1	Discharge Chamber	Stainless Steel	AISI 316 - 1.4401	AISI 316 - 1.4401	AISI 316 - 1.4401
2	Valve Cone	Stainless Steel	AISI 304 - 1.4301	AISI 316 - 1.4401	AISI 316 - 1.4401
3	Valve Seat	Stainless Steel/Rubber	AISI 316 -1.4401 / NBR	AISI 316 -1.4401 / NBR	AISI 316 -1.4401 / PTFE
4	Top Bearing	Rubber	NBR	NBR	PTFE
5	Top Diffuser	Stainless Steel	AISI 304 - 1.4301	AISI 316 - 1.4401	AISI 316 - 1.4401
6	Impeller	Stainless Steel	AISI 304 - 1.4301	AISI 316 - 1.4401	AISI 316 - 1.4401
7	Wear Ring Impeller	Stainless Steel	AISI 304 - 1.4301	AISI 316 - 1.4401	AISI 316 - 1.4401
8	Nut for Conical Bush	Stainless Steel	AISI 304 - 1.4301	AISI 316 - 1.4401	AISI 316 - 1.4401
9	Conical Bush	Stainless Steel	AISI 304 - 1.4301	AISI 316 - 1.4401	AISI 316 - 1.4401
10	Diffuser	Stainless Steel	AISI 304 - 1.4301	AISI 316 - 1.4401	AISI 316 - 1.4401
11	Neck Ring	Stainless Steel/Rubber	AISI 316 -1.4401 / NBR	AISI 316 -1.4401 / NBR	AISI 316 -1.4401 / PTFE
12	Intermediate Bearing	Rubber	NBR	NBR	PTFE
13	Bottom Diffuser	Stainless Steel	AISI 304 - 1.4301	AISI 316 - 1.4401	AISI 316 - 1.4401
15	Nut Conical Bush for first Impeller	Stainless Steel	AISI 304 - 1.4301	AISI 316 - 1.4401	AISI 316 - 1.4401
14	Uptrust Washer	Teflon	PTFE	PTFE	PTFE
16	Suction Interconnector	Stainless Steel	AISI 316 - 1.4401	AISI 316 - 1.4401	AISI 316 - 1.4401
17	Top Flange Suction Interconnector	Stainless Steel	AISI 316 - 1.4401	AISI 316 - 1.4401	AISI 316 - 1.4401
18	Strainer	Stainless Steel	AISI 304 - 1.4301	AISI 316 - 1.4401	AISI 316 - 1.4401
19	Shaft	Stainless Steel	AISI 431 - 1.4057	AISI 904L - 1.4539	AISI 904L - 1.4539
20	Coupling	Stainless Steel	AISI 304 - 1.4301	AISI 904L - 1.4539	AISI 904L - 1.4539
21	Cable Guards	Stainless Steel	AISI 304 - 1.4301	AISI 316 - 1.4401	AISI 316 - 1.4401
22	Strap	Stainless Steel	AISI 304 - 1.4301	AISI 316 - 1.4401	AISI 316 - 1.4401
23	Nut M12	Stainless Steel	AISI 316 - 1.4401	AISI 316 - 1.4401	AISI 316 - 1.4401



Fits to pump type	Description	Material	Motor Size	Reference
6" WPS® 16-1	Shroud Ø160 (180) x 400	1.4301 - AISI 304	4" up to 0,55 kW	76010
6" WPS® 16-2 upto 4	Shroud Ø160 (180) x 500	1.4301 - AISI 304	4" up to 2,2 kW	76020
6" WPS® 30-1 upto 2				
6" WPS® 16-5 upto 10	Shroud Ø160 (180) x 800	1.4301 - AISI 304	4" up to 5,5 kW	76030
6" WPS® 30-3 upto 6				
6" WPS® 16-11 upto 13	Shroud Ø160 (180) x 1000	1.4301 - AISI 304	4" up to 7,5 kW	76040
6" WPS® 30-7 upto 8				

6" WPS® 16-7 upto 20	Shroud Ø180 (200) x 800	1.4301 - AISI 304	6" up to 11 kW	76050
6" WPS® 30-4 upto 13				
6" WPS® 16-21 upto 24	Shroud Ø180 (200) x 1000	1.4301 - AISI 304	6" Rew. of 13 kW	76060
6" WPS® 30-14 upto 15				
6" WPS® 16-25 upto 40	Shroud Ø180 (200) x 1000	1.4301 - AISI 304	6" up to 22 kW	76070
6" WPS® 30-16 upto 26				
6" WPS® 16-43 upto 48	Shroud Ø180 (200) x 1250	1.4301 - AISI 304	6" Rew. of 26 kW	76080
6" WPS® 30-27 upto 31				
6" WPS® 16-51 upto 53	Shroud Ø180 (200) x 1250	1.4301 - AISI 304	6" up to 30 kW	76090
6" WPS® 30-32 upto 35				
6" WPS® 16-55 upto 60	Shroud Ø180 (200) x 1750	1.4301 - AISI 304	6" Rew. of 37 kW	76100
6" WPS® 30-39 upto 43				
6" WPS® 30-46 upto 49	Shroud Ø180 (200) x 1750	1.4301 - AISI 304	6" Enc. of 45 kW	76110

6" WPS® 45-1-B upto 2-BB	Shroud Ø180 (200) x 500	1.4301 - AISI 304	4" up to 2,2 kW	76120
6" WPS® 60-1				
6" WPS® 45-1 upto 4-C	Shroud Ø180 (200) x 800	1.4301 - AISI 304	4" up to 5,5 kW	76130
6" WPS® 60-2-B upto 3				
6" WPS® 45-4 upto 5	Shroud Ø180 (200) x 1000	1.4301 - AISI 304	4" up to 7,5 kW	76140
6" WPS® 60-4				

6" WPS® 45-3-C upto 8-C	Shroud Ø200 (220) x 800	1.4301 - AISI 304	6" up to 11 kW	76150
6" WPS® 60-2 upto 6				
6" WPS® 45-8 upto 9-C	Shroud Ø200 (220) x 1000	1.4301 - AISI 304	6" Rew. of 13 kW	76160
6" WPS® 60-7 upto 8-B				
6" WPS® 45-9 upto 15	Shroud Ø200 (220) x 1000	1.4301 - AISI 304	6" up to 22 kW	76170
6" WPS® 60-8 upto 12				
6" WPS® 45-16 upto 17	Shroud Ø200 (220) x 1250	1.4301 - AISI 304	6" Rew. of 26 kW	76180
6" WPS® 60-13 upto 15				
6" WPS® 45-18 upto 20	Shroud Ø200 (220) x 1250	1.4301 - AISI 304	6" up to 30 kW	76190
6" WPS® 60-16 upto 17				
6" WPS® 45-21 upto 24	Shroud Ø200 (220) x 1500	1.4301 - AISI 304	6" Rew. of 37 kW	76200
6" WPS® 60-18 upto 21				
6" WPS® 45-25 upto 30	Shroud Ø200 (220) x 1750	1.4301 - AISI 304	6" Enc. of 45 kW	76210
6" WPS® 60-22 upto 24				



Screen Ø160 x 192	1.4301 - AISI 304	Screen for shroud for 6" WPS 16-30 with 4" motor	76300
Screen Ø160 x 400	1.4301 - AISI 304	Screen for shroud for 6" WPS 16-30 with 4" motor	76500
Screen Ø180 x 192	1.4301 - AISI 304	Screen for shroud for 6" WPS 16-30 with 6" motor	76310
Screen Ø180 x 400	1.4301 - AISI 304	Screen for shroud for 6" WPS 16-30 with 6" motor	76510
Screen Ø200 x 192	1.4301 - AISI 304	Screen for shroud for 6" WPS 45-60 with 6" motor	76320
Screen Ø200 x 400	1.4301 - AISI 304	Screen for shroud for 6" WPS 45-60 with 6" motor	76530



Set of 2 supports for shroud Ø160 mm - 6" WPS 16-30	1.4301 - AISI 304	76400
Set of 2 supports for shroud Ø180 mm - 6" WPS 16-30	1.4301 - AISI 304	76410
Set of 3 supports for shroud Ø180 mm - 6" WPS 16-30	1.4301 - AISI 304	76420
Set of 2 supports for shroud Ø200 mm - 6" WPS 45-60	1.4301 - AISI 304	76440
Set of 3 supports for shroud Ø200 mm - 6" WPS 45-60	1.4301 - AISI 304	76450

Cooling shrouds in material 1.4401 - AISI 316 are available upon request

General Data

All the internal and external metal components of the 8" WPS® pumps are constructed of stainless steel AISI 304 - 1.4301 or AISI 316-1.4401 throughout. The suction interconnector and discharge chamber are casted.

8" WPS® submersible pumps are suitable for both continuous and intermittent operation for a variety of applications:

- General water supply
- Waterworks and fountains
- Irrigation
- Tank applications
- Pressure boosting
- Heating pumps
- Dewatering, mining and other industrial applications

Note: For other applications, please contact Well Pumps.



Pump and motor range

8" WPS® pump range consists of two flow models: 80, 100, 130 and 150 m³/h.

The pump-end is entirely made out of Stainless Steel DIN 1.4301, AISI 304 or 1.4401, AISI 316.

The pumps are standard equipped with a 6" motor up to 30kW and a 8" submersible motor from 37kW up to 110kW power.

8" WPS®

Specifications of the pump

The 8" WPS® pump have a capacity up to 190 m³/h and a maximum head of 450m.

The rotation is counter clockwise when looking into the discharge.

Coupling to the motor following NEMA standard.

The 8" WPS® pumps can run continuously in vertical or horizontal position.

Overall diameter of the pump is 190 mm and thus fits into 8" or larger drilled wells.

Pipe connection

All pump types have a treaded pipe connection:

8" WPS® 80: Rp 5"

8" WPS® 100: Rp 5"

8" WPS® 130: Rp 5"

8" WPS® 150: Rp 5"

A discharge adaptor to Rp 4" or flange adaptors are available on request.

Pump identification code

Example

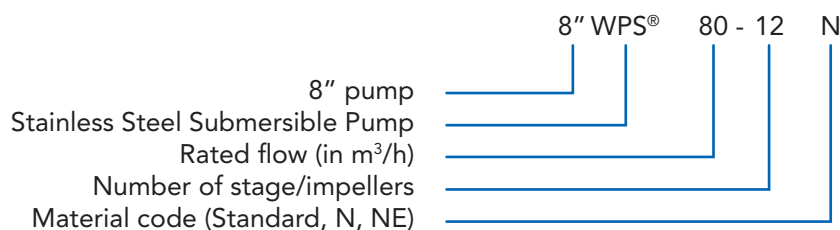

Pumped liquids

8"WPS® submersible pumps are designed for pumping thin, clean, non-aggressive and non-explosive liquids, not containing solid particles.

8"WPS® pumps are suitable for pumping liquids with a content of sand up to 50 g/m³. A higher content of sand will shorten pump life.

The maximum fluid temperature is 30°C. For higher temperatures, please contact Well Pumps.

Construction features

- Coupling and motor flange of pump-end are suitable for connection to motors in accordance with NEMA standard.
- Jam free spring loaded check valve, built in the discharge chamber, is designed for low loss of head.
- Generously dimensioned intermediate bearing located at each stage of the pump in order to perfectly align the shaft and optimize the lubrication.
- Hydraulic profiles are optimized for the attainment of high efficiencies.
- Resistance to corrosion and abrasion, i.e. the same inherent qualities of stainless steel (AISI 304 - 1.4301 or AISI316-1.4401). Models 8"WPS® 130 and 10"WPS® 150 are also available in Duplex steel.
- Great ease of dismantling and assembly.

Curve Conditions

- Curve tolerances according to ISO 9906, 2012 Class 3B.
- The performance curves show pump performance at actual speed of the standard motor range.
- The measurements were made with airless water at a temperature of 20°C and a kinematic viscosity of 1 mm²/s (1 cSt). For pumping liquids with a higher density than clear water, motors must be used with correspondingly higher outputs.
- Q/H: The curves are inclusive of valve and inlet losses at the actual speed.
- Power curve: P₂ shows pump input power at the actual speed for each individual pump size.
- Efficiency curve: η shows pump efficiency.

Service

The pump and motor are very easy to maintain and repair. The modular pump and motor design facilitates installation and service.

Performance Curves

Performance Curves 8" WPS® 80 and 8" WPS® 80 N(E)



8" WPS® 80

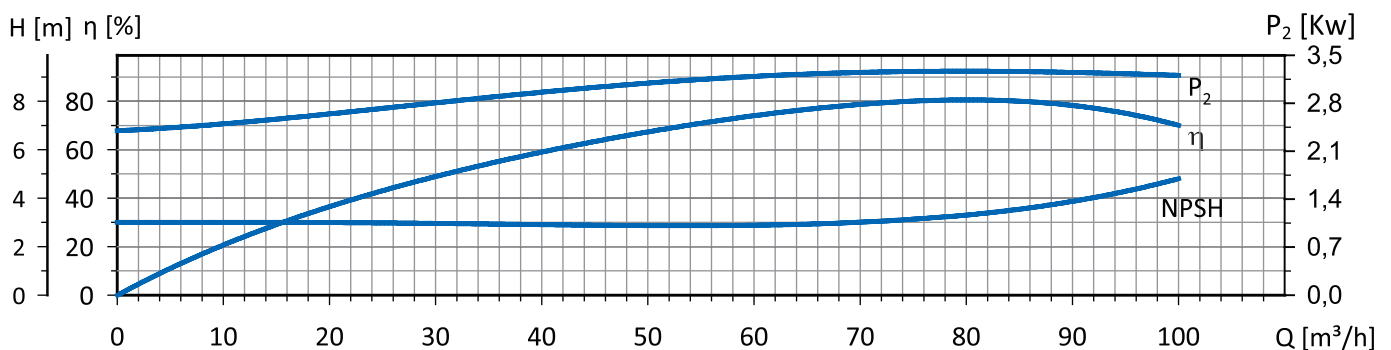
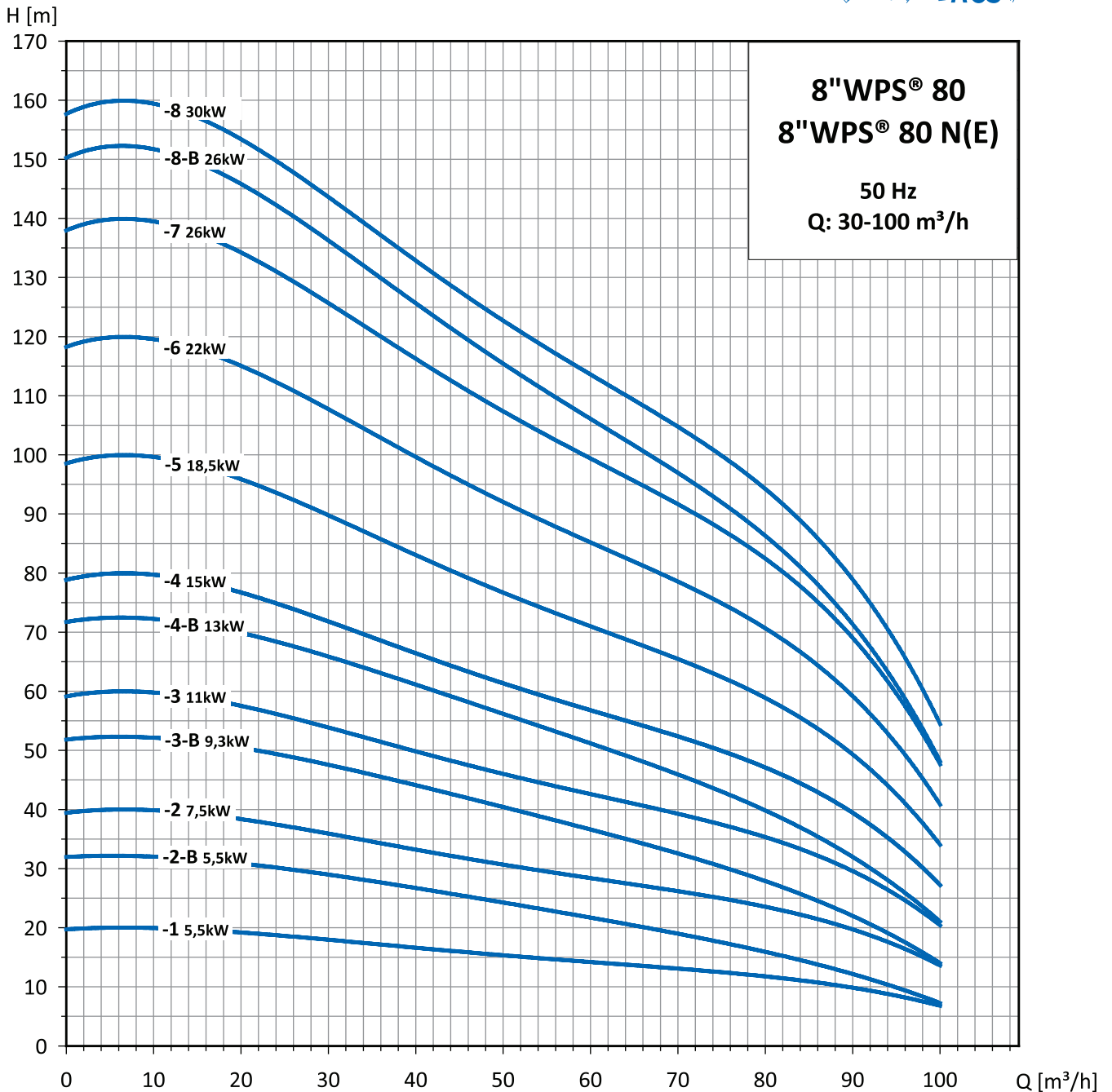

Curves Tolerances according to ISO 9906:2012 Grade 3B

Performance Curves 8"WPS® 80 and 8"WPS® 80 N(E)

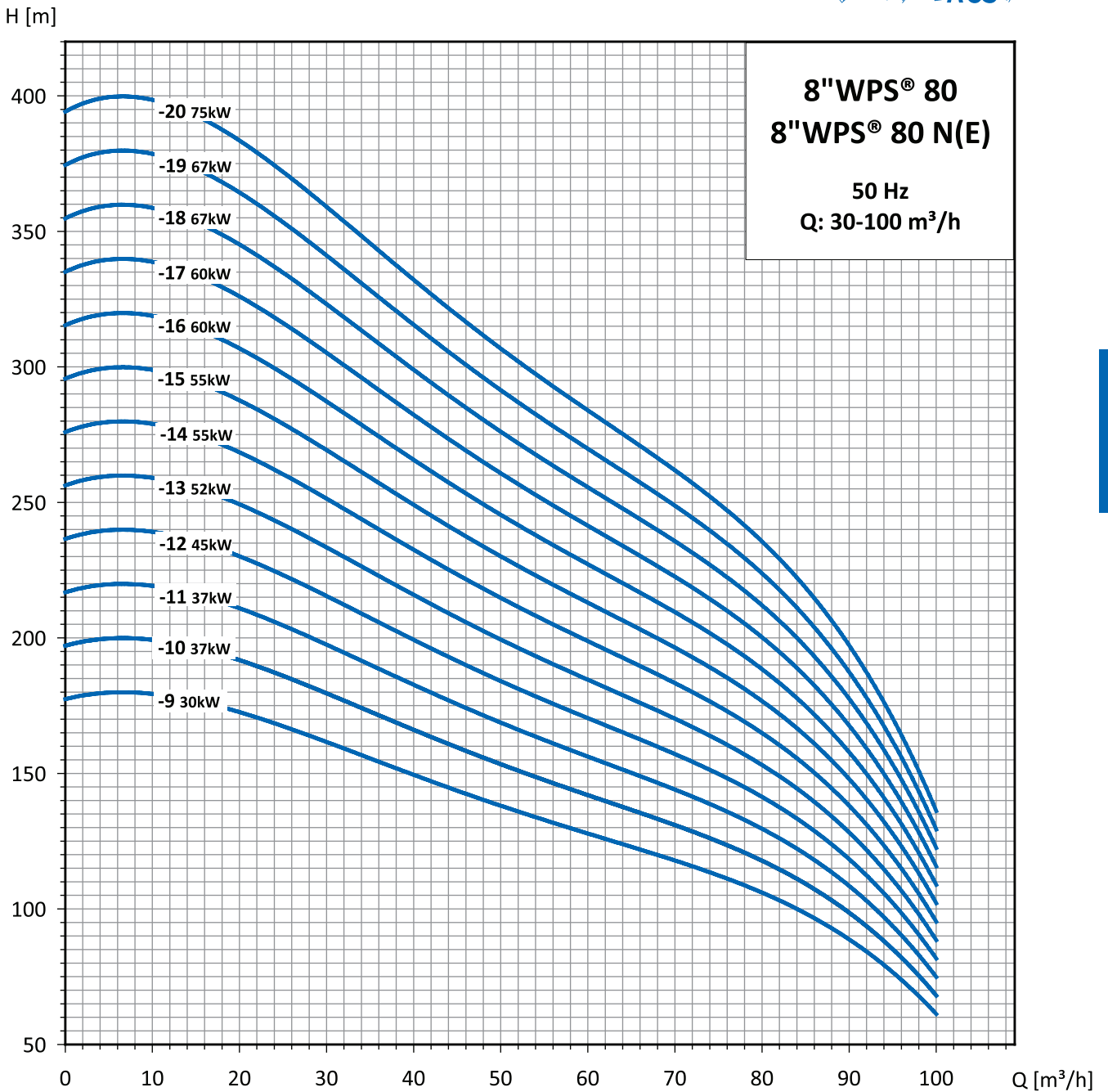

8"WPS®

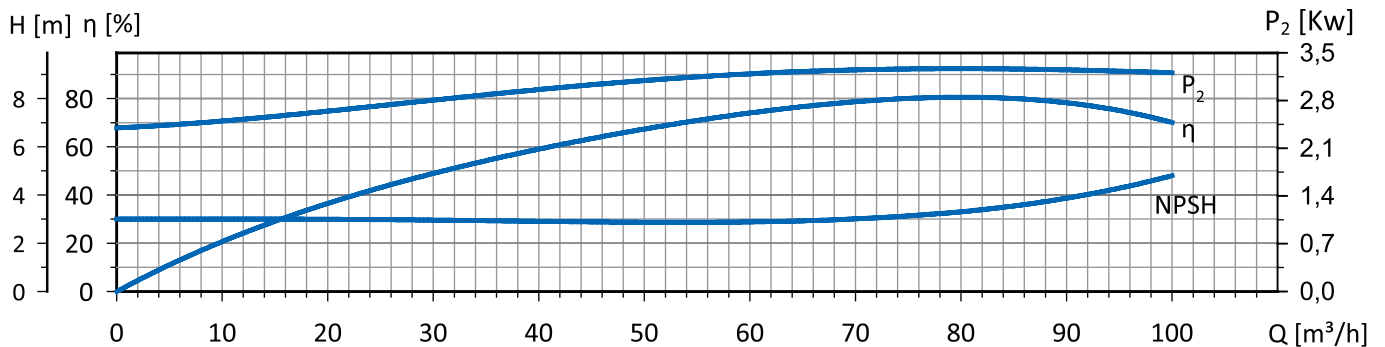

Curves Tolerances according to ISO 9906:2012 Grade 3B

Technical Data

Selection Chart 8"WPS® 80 and 8"WPS® 80 N(E)

Pump Type	Pump Power P ₂		Flow [m ³ /h]						Full load current
	[kW]	[HP]	0	20	40	60	80	100	3x400V
8"WPS® 80-1	5,5	7,5	20	19	17	14	12	7	9,5
8"WPS® 80-2-B	5,5	7,5	32	31	26	22	16	7	12,5
8"WPS® 80-2	7,5	10,0	40	39	33	28	24	14	15,2
8"WPS® 80-3-B	9,3	12,5	52	51	44	37	28	14	20,3
8"WPS® 80-3	11,0	15,0	59	58	50	43	35	20	23,0
8"WPS® 80-4-B	13,0	17,5	72	70	61	51	40	21	29,6
8"WPS® 80-4	15,0	20,0	79	77	66	57	47	27	29,0
8"WPS® 80-5	18,5	25,0	99	97	83	71	59	34	41,0
8"WPS® 80-6	22,0	30,0	119	116	99	85	71	41	53,0
8"WPS® 80-7	26,0	35,0	139	135	116	99	83	48	35,0
8"WPS® 80-8-B	26,0	35,0	151	146	136	115	85	48	41,0
8"WPS® 80-8	30,0	40,0	158	154	132	114	94	54	53,0
8"WPS® 80-9	30,0	40,0	178	174	149	128	106	61	56,0
8"WPS® 80-10	37,0	50,0	198	193	165	142	118	68	59,0
8"WPS® 80-11	37,0	50,0	218	212	182	156	130	75	63,0
8"WPS® 80-12	45,0	60,0	238	232	198	170	142	82	78,0
8"WPS® 80-13	52,0	70,0	257	251	215	185	153	88	80,0
8"WPS® 80-14	55,0	75,0	277	270	231	199	165	95	90,0
8"WPS® 80-15	55,0	75,0	297	290	248	213	177	102	86,0
8"WPS® 80-16	60,0	85,0	317	309	264	227	189	109	95,0
8"WPS® 80-17	60,0	85,0	337	328	281	241	201	116	115,0
8"WPS® 80-18	67,0	90,0	356	347	297	256	212	122	120,0
8"WPS® 80-19	67,0	90,0	346	367	314	270	224	129	130,0
8"WPS® 80-20	75,0	100,0	369	386	330	284	236	136	135,0

Dimensions and Weights 8"WPS® 80 and 8"WPS® 80 N(E)

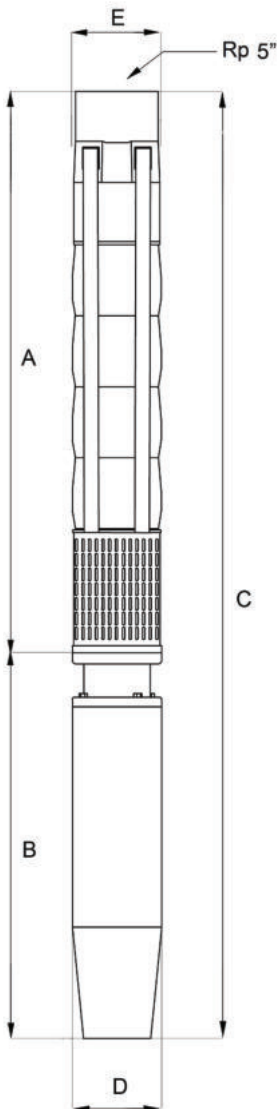

Pump Type	A [mm]	B [mm]	C [mm]	D [mm]	E [mm]	E* [mm]	Motor Type	Weight [kg]	
								Pump end	Electro-pump
8"WPS® 80-1	618	614	1232	137	178	186	6"	25,0	66,9
8"WPS® 80-2-B	746	614	1360	137	178	186	6"	29,0	70,9
8"WPS® 80-2	746	646	1392	137	178	186	6"	29,0	75,0
8"WPS® 80-3-B	874	679	1553	137	178	186	6"	32,0	80,3
8"WPS® 80-3	874	711	1585	137	178	186	6"	32,0	83,7
8"WPS® 80-4-B	1003	809	1812	145	178	186	6"	36,0	92,0
8"WPS® 80-4	1003	776	1779	137	178	186	6"	36,0	93,5
8"WPS® 80-5	1131	842	1973	137	178	186	6"	36,0	100,1
8"WPS® 80-6	1259	907	2166	137	178	186	6"	43,0	113,1
8"WPS® 80-7	1387	1094	2481	145	178	186	6"	47,0	132,0
8"WPS® 80-8-B	1515	1094	2609	145	178	186	6"	50,0	135,0
8"WPS® 80-8	1515	1037	2552	137	178	186	6"	50,0	134,7
8"WPS® 80-8	1515	925	2440	189	178	186	8"	50,0	190,0
8"WPS® 80-9	1644	1037	2681	137	178	186	6"	54,0	138,7
8"WPS® 80-9	1644	925	2569	189	178	186	8"	54,0	194,0
8"WPS® 80-10	1772	1274	3046	145	178	186	6"	57,0	159,0
8"WPS® 80-10	1772	1000	2772	189	178	186	8"	57,0	197,0
8"WPS® 80-11	1900	1274	3174	145	178	186	6"	61,0	163,0
8"WPS® 80-11	1900	1000	2900	189	178	186	8"	61,0	201,0
8"WPS® 80-12	2039	1629	3668	137	178	186	6"	66,0	217,0
8"WPS® 80-12	2039	1077	3116	189	178	186	8"	66,0	222,0
8"WPS® 80-13	2168	1077	3245	189	178	186	8"	70,0	249,0
8"WPS® 80-14	2296	1204	3500	189	178	186	8"	74,0	253,0
8"WPS® 80-15	2424	1204	3628	189	178	186	8"	77,0	256,0
8"WPS® 80-16	2552	1470	4022	189	178	186	8"	80,0	278,0
8"WPS® 80-17	2681	1470	4151	189	178	186	8"	84,0	282,0
8"WPS® 80-18	2809	1470	4279	189	178	186	8"	88,0	286,0
8"WPS® 80-19	2937	1394	4331	189	178	186	8"	92,0	290,0
8"WPS® 80-20	3065	1394	4459	189	178	186	8"	95,0	310,0

* With 2 cable guards

Performance Curves

Performance Curves 8"WPS® 100 and 8"WPS® 100 N(E)

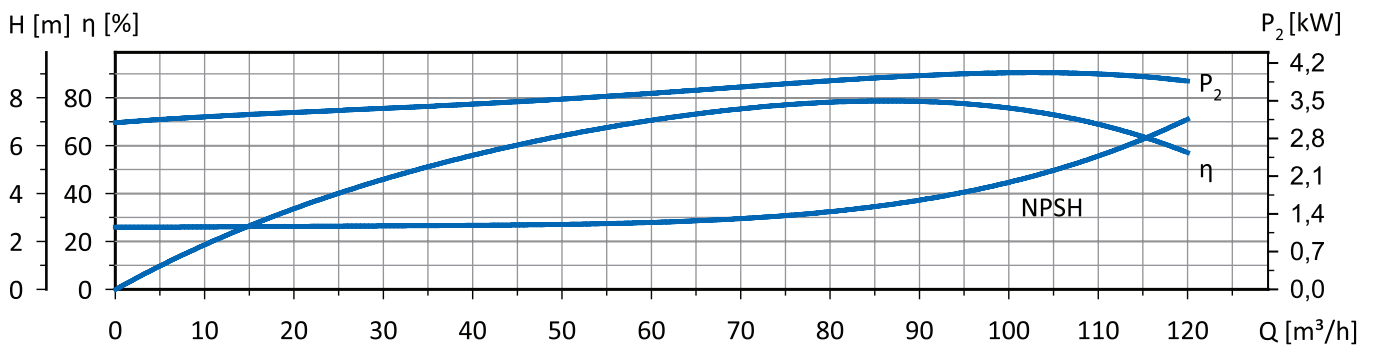
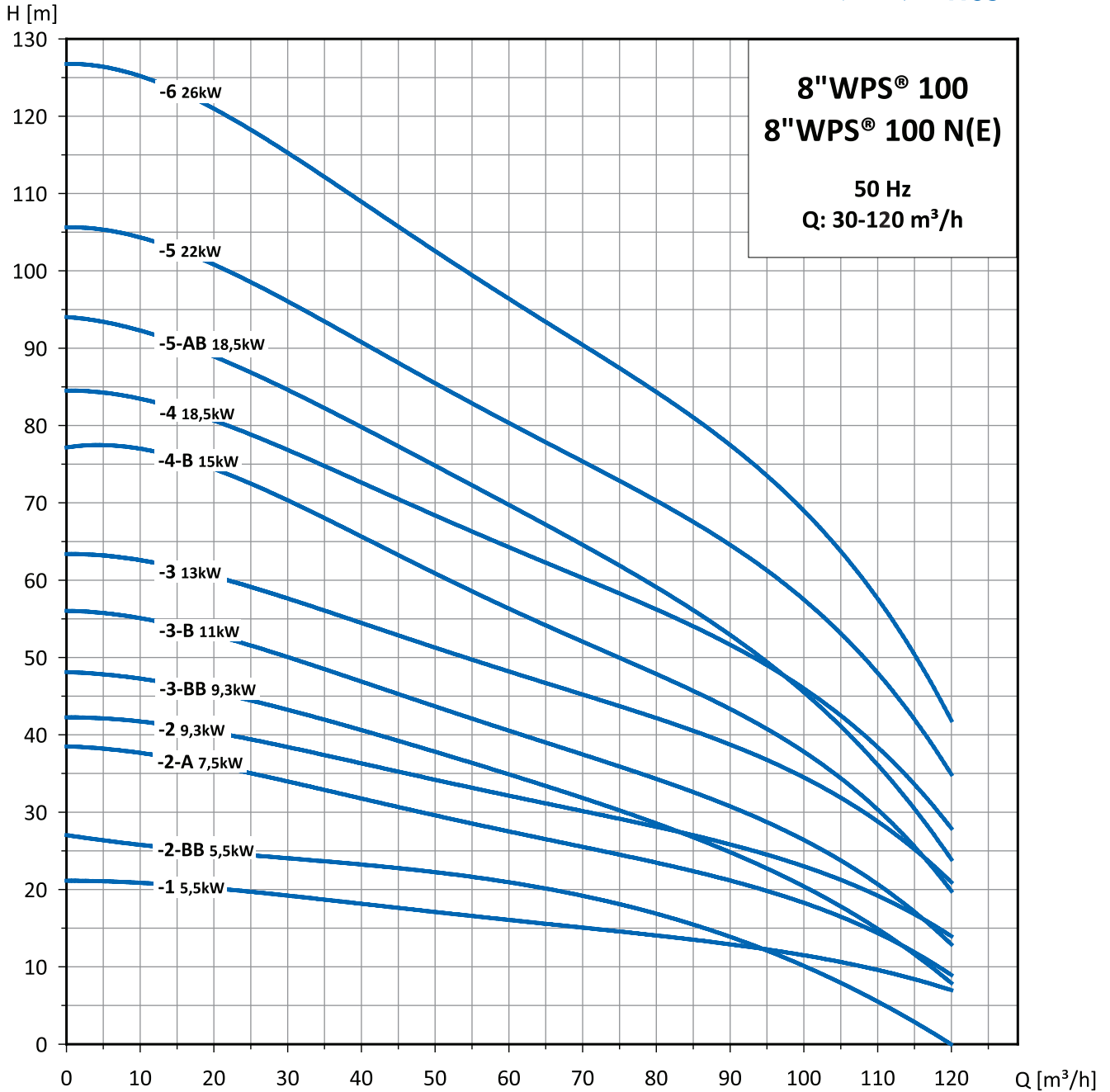

Curves Tolerances according to ISO 9906:2012 Grade 3B

Performance Curves 8"WPS® 100 and 8"WPS® 100 N(E)

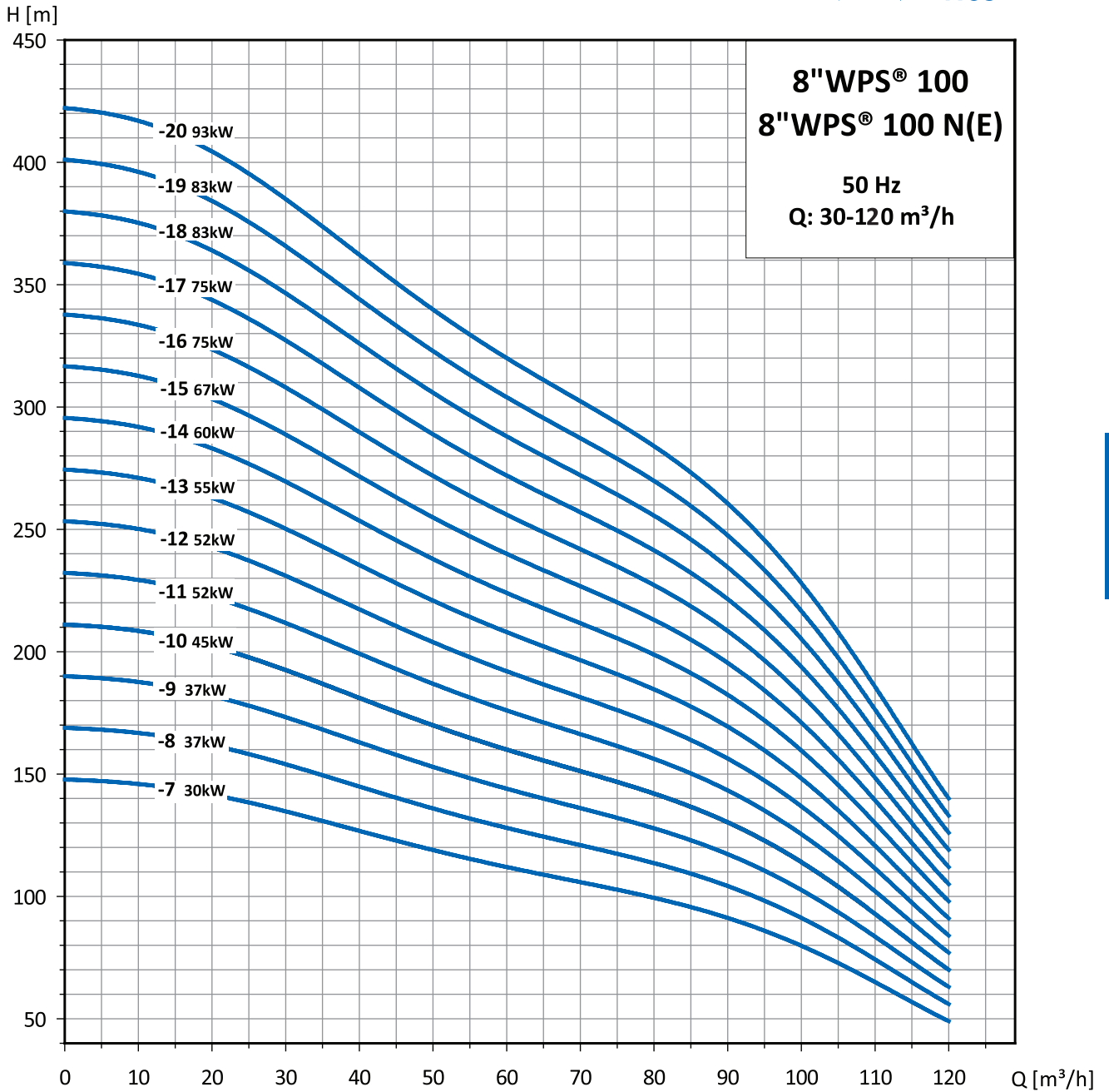

8"WPS® 8

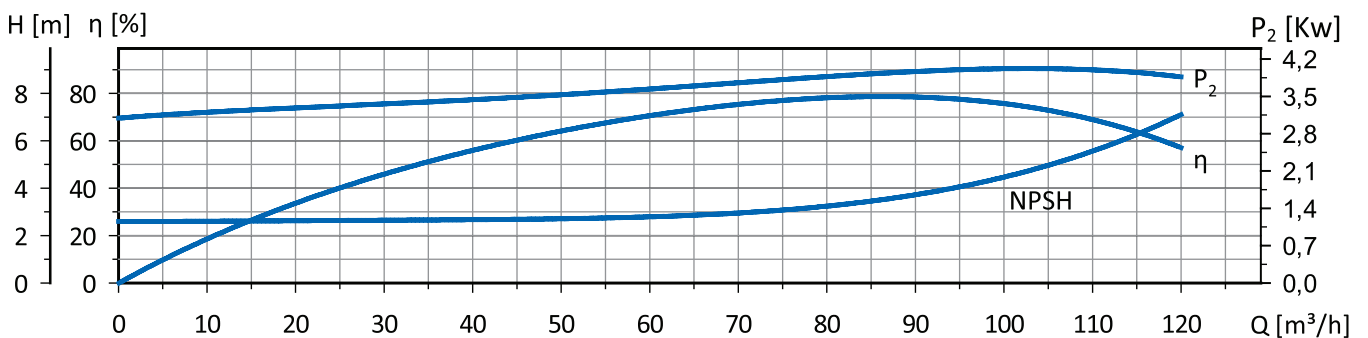

Technical Data

Selection Chart 8"WPS® 100 and 8"WPS® 100 N(E)

Pump Type	Pump Power P ₂		Flow [m ³ /h]							Full load current
	[kW]	[HP]	0	20	40	60	80	100	120	3x400V
8"WPS® 100-1	5,5	7,5	21	20	18	16	14	11	7	10,2
8"WPS® 100-2-BB	5,5	7,5	27	25	23	21	17	10	0	12,5
8"WPS® 100-2-A	7,5	10,0	39	36	32	27	24	18	9	15,3
8"WPS® 100-2	9,3	12,5	42	40	36	32	28	23	14	19,8
8"WPS® 100-3-BB	9,3	12,5	48	46	40	35	29	20	8	20,7
8"WPS® 100-3-B	11,0	15,0	56	53	47	40	35	26	13	22,0
8"WPS® 100-3	13,0	17,5	63	61	54	48	43	34	21	28,5
8"WPS® 100-4-B	15,0	20,0	77	75	65	56	49	37	20	31,0
8"WPS® 100-4	18,5	25,0	84	81	72	64	57	46	28	33,0
8"WPS® 100-5-AB	18,5	25,0	94	89	80	69	60	45	24	38,5
8"WPS® 100-5	22,0	30,0	106	101	91	80	71	57	35	43,0
8"WPS® 100-6	26,0	35,0	127	121	109	96	85	68	42	56,7
8"WPS® 100-7	30,0	40,0	148	142	127	112	99	80	49	60,0
8"WPS® 100-8	37,0	50,0	169	162	145	128	114	91	56	75,0
8"WPS® 100-9	37,0	50,0	190	182	163	144	128	103	63	81,5
8"WPS® 100-10	45,0	60,0	211	202	181	160	142	114	70	92,0
8"WPS® 100-11	52,0	70,0	232	222	199	176	156	125	77	89,0
8"WPS® 100-12	52,0	70,0	253	243	217	192	170	137	84	101,0
8"WPS® 100-13	55,0	75,0	274	263	235	208	185	148	91	110,0
8"WPS® 100-14	60,0	80,0	296	283	254	224	199	160	98	116,0
8"WPS® 100-15	67,0	90,0	317	303	272	240	213	171	105	125,0
8"WPS® 100-16	75,0	100,0	338	324	290	256	227	182	112	135,0
8"WPS® 100-17	75,0	100,0	359	344	308	272	241	194	119	143,0
8"WPS® 100-18	83,0	111,0	380	364	326	288	256	205	126	145,0
8"WPS® 100-19	83,0	111,0	401	384	344	304	270	217	133	155,0
8"WPS® 100-20	93,0	125,0	422	404	362	320	284	228	140	184,0

8"WPS®

Dimensions and Weights 8"WPS® 100 and 8"WPS® 100 N(E)

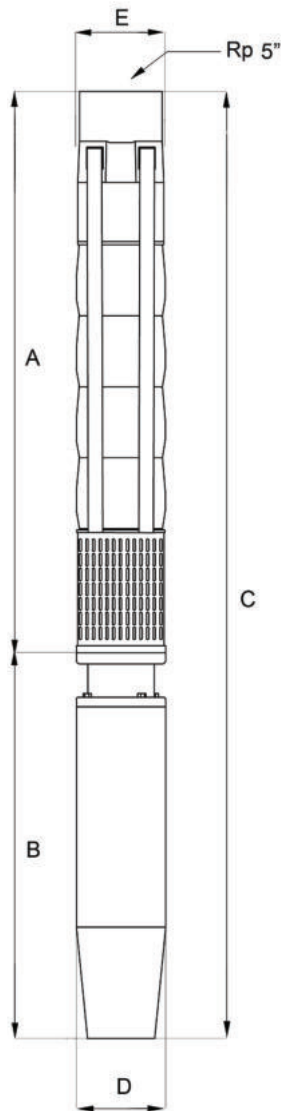

Pump Type	A [mm]	B [mm]	C [mm]	D [mm]	E [mm]	E* [mm]	Motor Type	Weight [kg]	
								Pump end	Electro-pump
8"WPS® 100-1	618	614	1232	137	178	186	6"	25,0	66,9
8"WPS® 100-2-BB	746	614	1360	137	178	186	6"	29,0	70,9
8"WPS® 100-2-A	746	646	1392	137	178	186	6"	29,0	75,0
8"WPS® 100-2	746	679	1425	137	178	186	6"	29,0	77,3
8"WPS® 100-3-BB	874	679	1553	137	178	186	6"	32,0	80,3
8"WPS® 100-3-B	874	711	1585	137	178	186	6"	32,0	83,7
8"WPS® 100-3	874	809	1683	144	178	186	6"	32,0	88,0
8"WPS® 100-4-B	1003	776	1779	137	178	186	6"	36,0	93,5
8"WPS® 100-4	1003	842	1845	137	178	186	6"	36,0	100,1
8"WPS® 100-5-AB	1131	842	1973	137	178	186	6"	40,0	104,1
8"WPS® 100-5	1131	907	2038	137	178	186	6"	40,0	110,1
8"WPS® 100-6	1259	1094	2353	144	178	186	6"	43,0	128,0
8"WPS® 100-7	1387	1037	2424	137	178	186	6"	47,0	131,7
8"WPS® 100-7	1387	1140	2527	189	178	186	8"	47,0	187,0
8"WPS® 100-8	1515	1274	2789	137	178	186	6"	50,0	152,0
8"WPS® 100-8	1515	1140	2655	189	178	186	8"	50,0	190,0
8"WPS® 100-9	1644	1274	2918	144	178	186	6"	54,0	156,0
8"WPS® 100-9	1783	1629	3412	189	178	186	8"	59,0	210,0
8"WPS® 100-10	1783	1230	3013	137	178	186	6"	59,0	215,0
8"WPS® 100-10	1911	1340	3251	189	178	186	8"	62,0	241,0
8"WPS® 100-11	2039	1340	3379	189	178	186	8"	66,0	245,0
8"WPS® 100-12	2168	1340	3508	189	178	186	8"	70,0	249,0
8"WPS® 100-13	2296	1470	3766	189	178	186	8"	73,0	271,0
8"WPS® 100-14	2424	1470	3894	189	178	186	8"	77,0	275,0
8"WPS® 100-15	2424	1470	3894	189	178	186	8"	77,0	275,0
8"WPS® 100-16	2039	1560	3599	189	178	186	8"	81,0	296,0
8"WPS® 100-17	2680	1560	4240	189	178	186	8"	84,0	299,0
8"WPS® 100-18	2809	1740	4549	189	178	186	8"	88,0	335,0
8"WPS® 100-19	2937	1740	4677	189	178	186	8"	92,0	339,0
8"WPS® 100-20	3065	1740	4805	189	178	186	8"	95,0	342,0

* With 2 cable guards

Performance Curves

Performance Curves 8"WPS® 130 and 8"WPS® 130 N

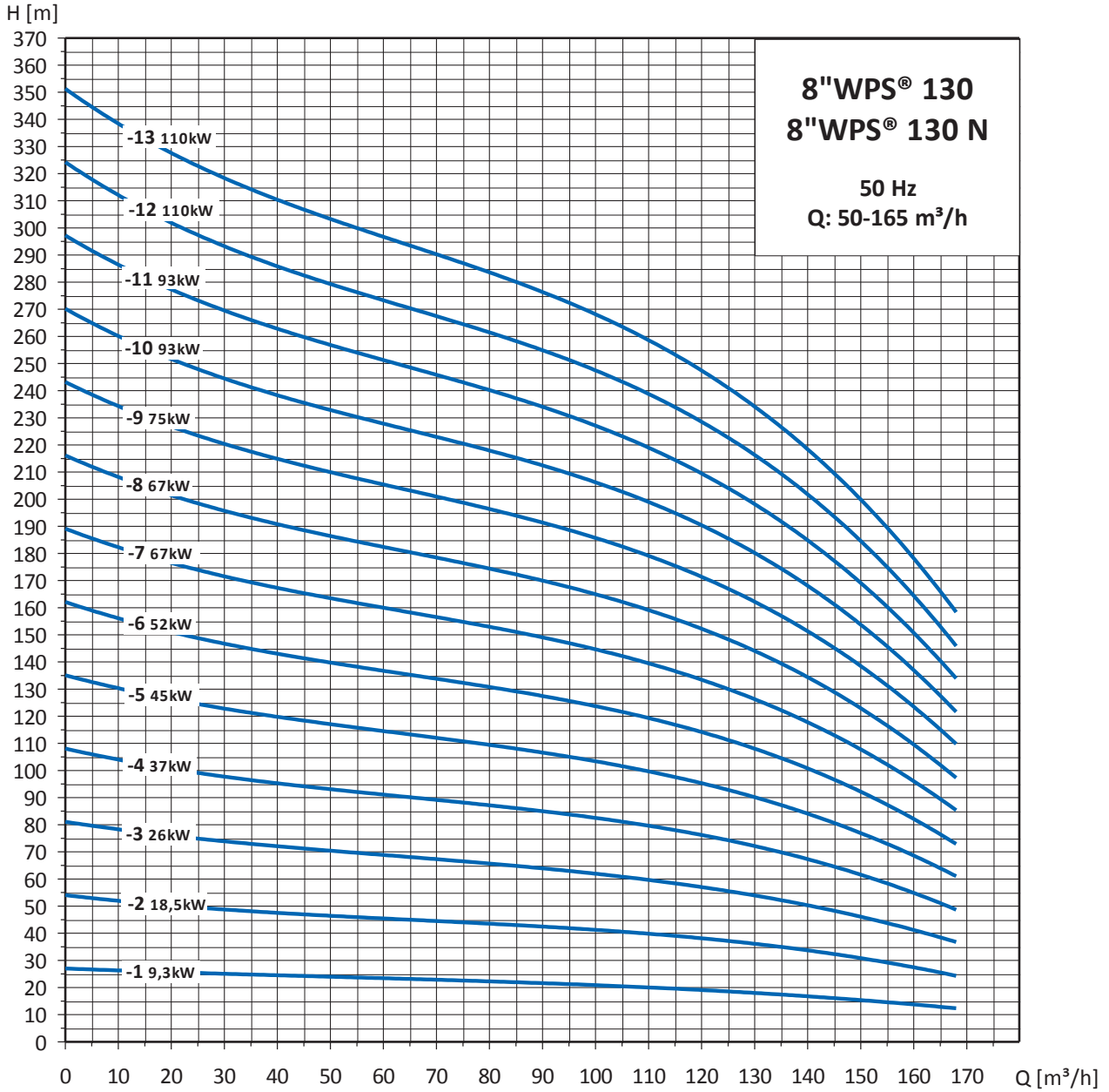

8"WPS® 130

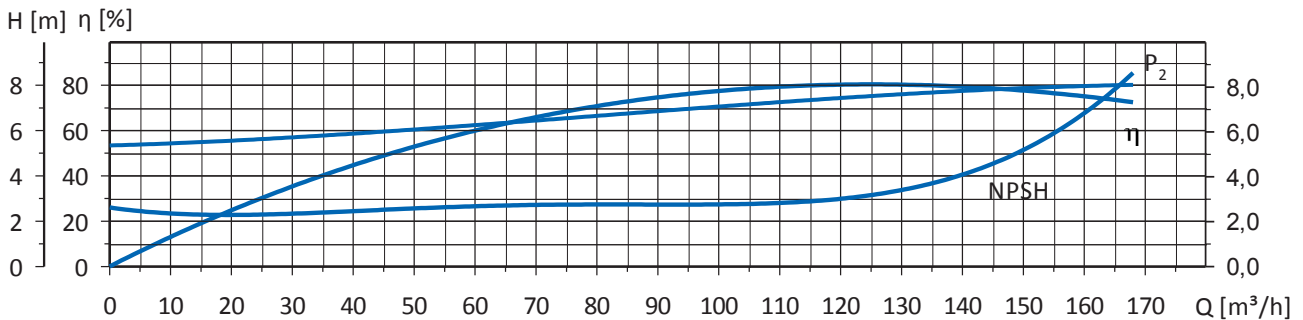

Selection Chart 8"WPS® 130 and 8"WPS® 130 N

Pump Type	Pump Power P ₂		Flow [m ³ /h]								Full load current
	[kW]	[HP]	0	50	70	90	110	130	150	165	3x400V
8"WPS® 130-1	9,3	12,5	27	24	23	21	20	17	15	13	19,8
8"WPS® 130-2	18,5	25,0	54	49	46	43	39	35	31	26	38,5
8"WPS® 130-3	26,0	35,0	81	73	69	64	59	52	46	40	56,7
8"WPS® 130-4	37,0	50,0	108	98	92	86	78	70	61	53	81,5
8"WPS® 130-5	45,0	60,0	135	122	115	107	98	87	76	66	92,0
8"WPS® 130-6	52,0	70,0	162	147	138	129	118	104	92	79	101,0
8"WPS® 130-7	67,0	90,0	189	171	162	150	137	122	107	93	110,0
8"WPS® 130-8	67,0	90,0	216	196	185	172	157	139	122	106	125,0
8"WPS® 130-9	75,0	100,0	243	220	208	193	177	157	137	119	143,0
8"WPS® 130-10	93,0	125,0	270	245	231	215	196	174	153	132	155,0
8"WPS® 130-11	93,0	125,0	297	269	254	236	216	191	168	146	183,0
8"WPS® 130-12	110,0	150,0	324	294	277	258	235	209	183	159	223,0
8"WPS® 130-13	110,0	150,0	351	318	300	279	255	226	198	172	223,0

Selection Chart 8"WPS® 130 and 8"WPS® 130 N

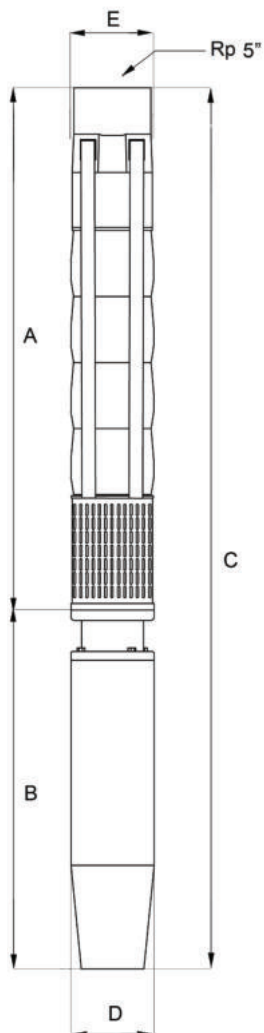

Pump Type	A [mm]	B [mm]	C [mm]	D [mm]	E [mm]	E* [mm]	Motor Type	Weight [kg]	
								Pump end	Electro-pump
8"WPS® 130-1	525	679	1204	139	190	195	6"	20,0	68,0
8"WPS® 130-2	650	842	1492	139	190	195	6"	27,0	91,0
8"WPS® 130-3	775	1114	1889	139	190	195	6"	33,0	115,0
8"WPS® 130-4	900	1421	2321	139	190	195	6"	40,0	142,0
8"WPS® 130-4	900	1140	2040	194	190	195	8"	40,0	180,0
8"WPS® 130-5	1025	1230	2255	139	190	195	6"	47,0	194,0
8"WPS® 130-5	1025	1340	2365	194	190	195	8"	47,0	203,0
8"WPS® 130-6	1150	1340	2490	194	190	195	8"	54,0	233,0
8"WPS® 130-7	1275	1340	2615	194	190	195	8"	60,0	239,0
8"WPS® 130-8	1400	1470	2870	194	190	195	8"	67,0	265,0
8"WPS® 130-9	1525	1560	3085	194	190	195	8"	74,0	289,0
8"WPS® 130-10	1650	1740	3390	194	190	195	8"	80,0	327,0
8"WPS® 130-10	1650	1419	3069	235	190	195	10"	80,0	354,0
8"WPS® 130-11	1775	1740	3515	194	190	195	8"	87,0	334,0
8"WPS® 130-11	1775	1419	3194	235	190	195	10"	87,0	287,0
8"WPS® 130-12	1900	1976	3876	194	190	195	8"	94,0	472,0
8"WPS® 130-12	1900	1529	3429	235	190	195	10"	94,0	409,0
8"WPS® 130-13	2025	1976	4001	194	190	195	8"	100,0	478,0
8"WPS® 130-13	2025	1529	3554	235	190	195	10"	100,0	415,0

* With 2 cable guards

Performance Curves

Performance Curves 8"WPS® 150 and 8"WPS® 150 N

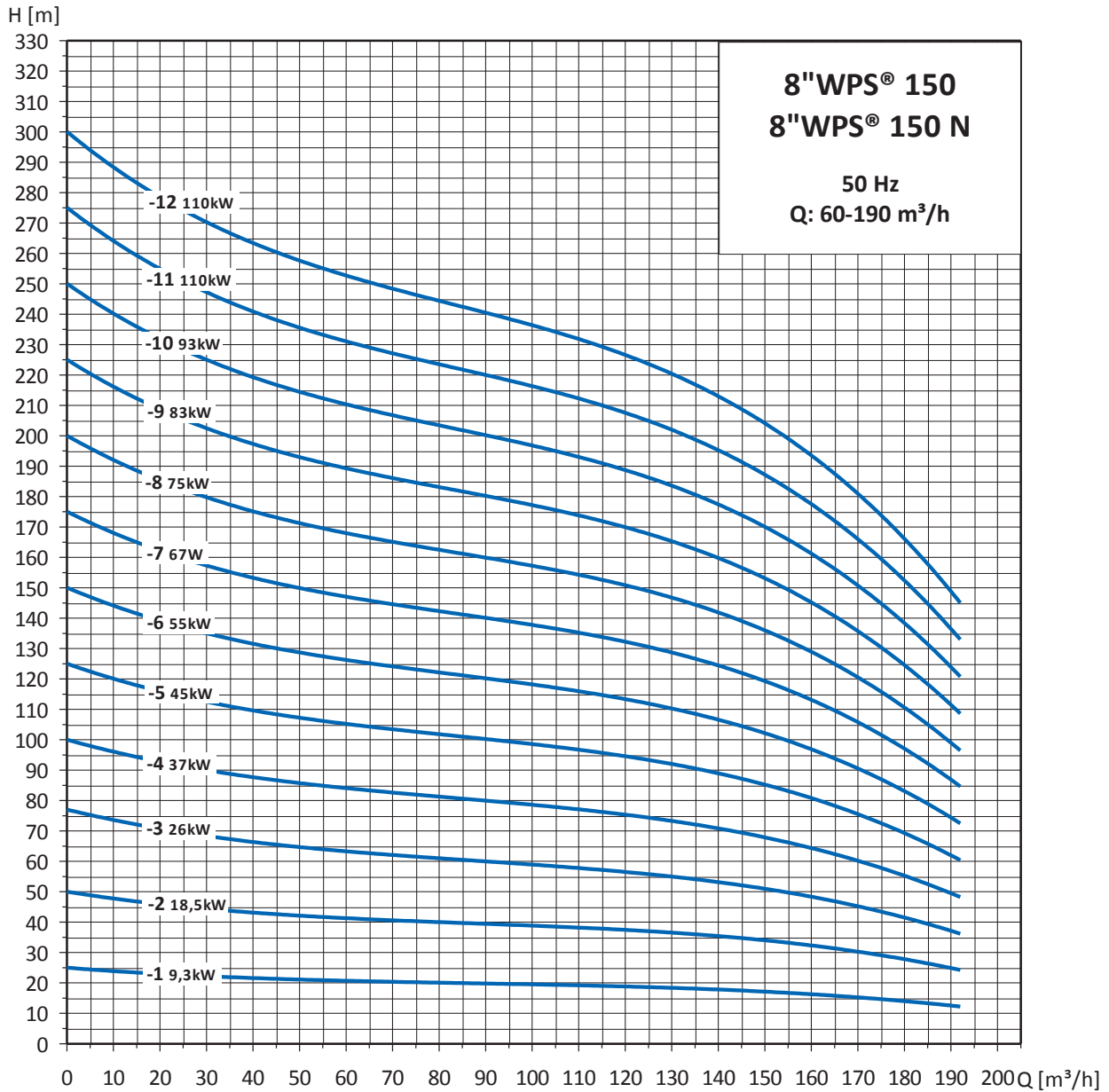

8"WPS® 150

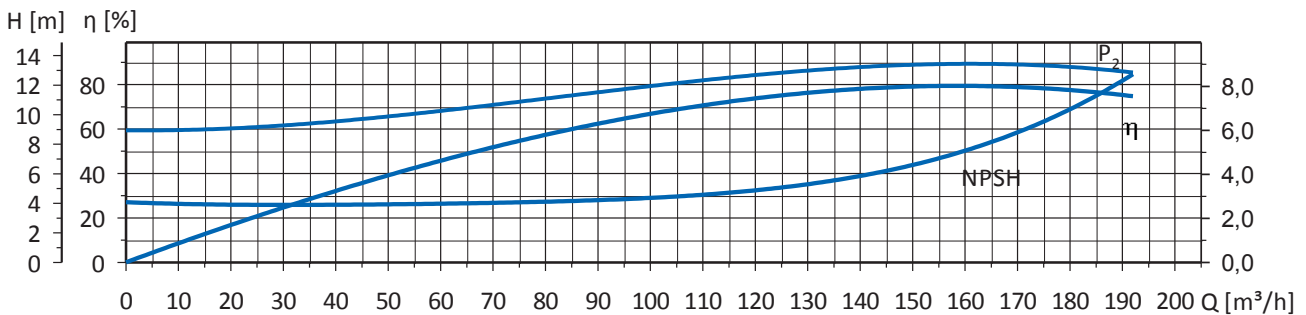

Selection Chart 8"WPS® 150 and 8"WPS® 150 N

Pump Type	Pump Power P ₂		Flow [m ³ /h]								Full load current
	[kW]	[HP]	0	50	90	110	130	150	170	190	3x400V
8"WPS® 150-1	9,3	12,5	25	22	20	19	18	17	15	12	19,8
8"WPS® 150-2	18,5	25,0	50	44	40	39	37	34	30	25	38,5
8"WPS® 150-3	26,0	35,0	75	66	60	58	55	51	45	37	56,7
8"WPS® 150-4	37,0	50,0	100	88	80	77	73	68	61	49	81,0
8"WPS® 150-5	45,0	60,0	125	110	101	96	92	86	76	61	92,0
8"WPS® 150-6	55,0	75,0	150	131	121	116	110	103	91	74	110,0
8"WPS® 150-7	67,0	90,0	175	153	141	135	128	120	106	86	125,0
8"WPS® 150-8	75,0	100,0	200	175	161	154	146	137	121	98	143,0
8"WPS® 150-9	83,0	110,0	225	197	181	173	165	154	136	110	145,0
8"WPS® 150-10	93,0	125,0	250	219	201	193	183	171	152	123	184,0
8"WPS® 150-11	110,0	150,0	275	241	221	212	201	188	167	135	222,0
8"WPS® 150-12	110,0	150,0	300	263	241	231	220	205	182	147	222,0

Selection Chart 8"WPS® 150 and 8"WPS® 150 N

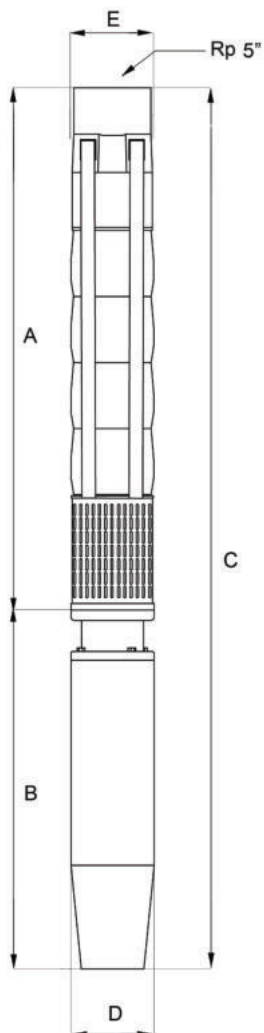

Pump Type	A [mm]	B [mm]	C [mm]	D [mm]	E [mm]	E* [mm]	Motor Type	Weight [kg]	
								Pump end	Electro-pump
8"WPS® 150-1	570	679	1249	139	190	195	6"	20,0	70,4
8"WPS® 150-2	720	842	1562	139	190	195	6"	27,0	93,0
8"WPS® 150-3	870	1114	1984	139	190	195	6"	34,0	124,0
8"WPS® 150-4	1020	1421	2441	139	190	195	6"	41,0	143,0
8"WPS® 150-4	1020	1140	2160	194	190	195	8"	41,0	181,0
8"WPS® 150-5	1170	1230	2400	139	190	195	6"	48,0	195,0
8"WPS® 150-5	1170	1340	2510	194	190	195	8"	48,0	206,0
8"WPS® 150-6	1320	1340	2660	194	190	195	8"	55,0	234,0
8"WPS® 150-7	1470	1470	2940	194	190	195	8"	62,0	260,0
8"WPS® 150-8	1620	1560	3180	194	190	195	8"	69,0	284,0
8"WPS® 150-9	1770	1740	3510	194	190	195	8"	76,0	323,0
8"WPS® 150-9	1770	1419	3189	235	190	195	10"	76,0	356,0
8"WPS® 150-10	1920	1740	3660	194	190	195	8"	83,0	330,0
8"WPS® 150-10	1920	1419	3339	235	190	195	10"	83,0	363,0
8"WPS® 150-11	2070	1976	4046	194	190	195	8"	90,0	468,0
8"WPS® 150-11	2070	1529	3599	235	190	195	10"	90,0	405,0
8"WPS® 150-12	2220	1976	4196	194	190	195	8"	97,0	475,0
8"WPS® 150-12	2220	1529	3749	235	190	195	10"	97,0	412,0

* With 2 cable guards

Technical Data

Material specification

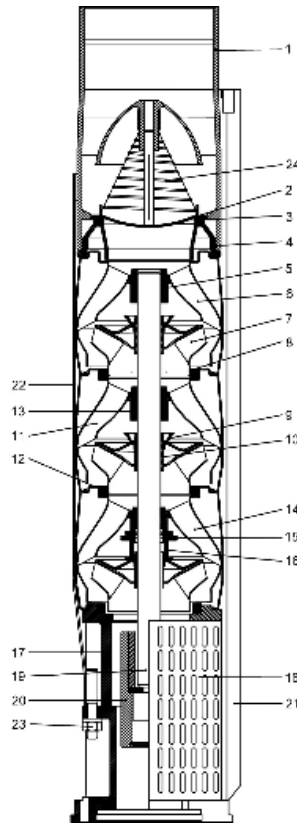

8"WPS® 80
 8"WPS® 100
 8"WPS® 130
 8"WPS® 150

8"WPS®

Pos.	Component	Material	8"WPS® Material Code	8"WPS®N Material Code	8"WPS®NE Material Code
1	Discharge Chamber	Stainless Steel	AISI 304 - 1.4301	AISI 316 - 1.4401	AISI 316 - 1.4401
2	Valve Cone	Stainless Steel	AISI 304 - 1.4301	AISI 316 - 1.4401	AISI 316 - 1.4401
3	Valve Seat	Stainless Steel/Rubber	AISI 316 -1.4401 / NBR	AISI 316 -1.4401 / NBR	PTFE
4	Valve seat Retainer	Stainless Steel	AISI 304 - 1.4301	AISI 316 - 1.4401	AISI 316 - 1.4401
5	Top Bearing	Rubber	NBR	NBR	PTFE
6	Top Diffuser	Stainless Steel	AISI 304 - 1.4301	AISI 316 - 1.4401	AISI 316 - 1.4401
7	Impeller	Stainless Steel	AISI 304 - 1.4301	AISI 316 - 1.4401	AISI 316 - 1.4401
8	Wear Ring Impeller	Stainless Steel	AISI 304 - 1.4301	AISI 316 - 1.4401	AISI 316 - 1.4401
9	Nut for Conical Bush	Stainless Steel	AISI 304 - 1.4301	AISI 316 - 1.4401	AISI 316 - 1.4401
10	Conical Bush	Stainless Steel	AISI 304 - 1.4301	AISI 316 - 1.4401	AISI 316 - 1.4401
11	Diffuser	Stainless Steel	AISI 304 - 1.4301	AISI 316 - 1.4401	AISI 316 - 1.4401
12	Neck Ring	Stainless Steel/Rubber	AISI 316 -1.4401 / NBR	AISI 316 -1.4401 / NBR	PTFE
13	Intermediate Bearing	Rubber	NBR	NBR	PTFE
14	Bottom Diffuser	Stainless Steel	AISI 304 - 1.4301	AISI 316 - 1.4401	AISI 316 - 1.4401
15	Uptrust Washer	Teflon	PTFE	PTFE	PTFE
16	Nut Conical Bush for first Impeller	Stainless Steel	AISI 304 - 1.4301	AISI 316 - 1.4401	AISI 316 - 1.4401
17	Suction Interconnector	Stainless Steel	AISI 304 - 1.4301	AISI 316 - 1.4401	AISI 316 - 1.4401
18	Strainer	Stainless Steel	AISI 304 - 1.4301	AISI 316 - 1.4401	AISI 316 - 1.4401
19	Shaft	Stainless Steel	AISI 431 - 1.4057	AISI 316 - 1.4401	AISI 316 - 1.4401
20	Coupling	Stainless Steel	AISI 304 - 1.4301	AISI 316 - 1.4401	AISI 316 - 1.4401
21	Cable Guard	Stainless Steel	AISI 304 - 1.4301	AISI 316 - 1.4401	AISI 316 - 1.4401
22	Strap	Stainless Steel	AISI 304 - 1.4301	AISI 316 - 1.4401	AISI 316 - 1.4401
23	Nut	Stainless Steel	AISI 316 - 1.4401	AISI 316 - 1.4401	AISI 316 - 1.4401
24	Spring	Stainless Steel	AISI 304 - 1.4301	AISI 316 - 1.4401	AISI 316 - 1.4401

Cooling Shrouds

The cooling shrouds are designed to ensure a sufficient flow velocity past the motor in order to provide sufficient cooling. For the following cases a cooling shroud is recommended:

- horizontal or vertical installation in a tank
- installation of the pump in the screen from the well
- installation in big sized well not ensuring enough cooling velocity. See table.

Minimum flow required for motor cooling in water up to 20°C.		
Casing or sleeve I.D. [mm (inches)]	6" motor, cooling flow 16cm/sec [m ³ /h]	8" motor, cooling flow 25cm/sec [m ³ /h]
203 (8")	10,2	3,9
254 (10")	20,4	20,0
305 (12")	31,8	40,5
355 (14")	48,6	63,8

To the shroud itself, a screen can be added. In case of horizontal installation a set of supports are available.

Fits to pump type	Description	Material	Motor Size	Reference
8"WPS® 80-1 upto 3	Shroud Ø210 (230) x 800	1.4301 - AISI 304	6" up to 11 kW	78010
8"WPS® 100-1 upto 3-B				
8"WPS® 80-4B	Shroud Ø210 (230) x 1000	1.4301 - AISI 304	6" Rew. of 13 kW	78020
8"WPS® 100-3				
8"WPS® 80-4 upto 6	Shroud Ø210 (230) x 1000	1.4301 - AISI 304	6" up to 22 kW	78030
8"WPS® 100-4-B upto 5				
8"WPS® 80-7 upto 8-B	Shroud Ø210 (230) x 1250	1.4301 - AISI 304	6" Rew. of 26 kW	78040
8"WPS® 100-6				
8"WPS® 80-8 upto 9	Shroud Ø210 (230) x 1250	1.4301 - AISI 304	6" up to 30 kW	78050
8"WPS® 100-7				
8"WPS® 80-10 upto 11	Shroud Ø210 (230) x 1500	1.4301 - AISI 304	6" Rew. of 37 kW*	78060
8"WPS® 100-8 upto 9				
8"WPS® 80-12	Shroud Ø210 (230) x 1800	1.4301 - AISI 304	6" Enc. of 45 kW*	78070
8"WPS® 100-10				
8"WPS® 80-8 upto 12	Shroud Ø256 (270) x 1250	1.4301 - AISI 304	8" up to 45 kW	78080
8"WPS® 100-7 upto 10				
8"WPS® 80-13 upto 19	Shroud Ø256 (270) x 1500	1.4301 - AISI 304	8" up to 67 kW	78090
8"WPS® 100-11 upto 15				
8"WPS® 80-4 upto 6	Shroud Ø256 (270) x 1800	1.4301 - AISI 304	8" up to 93 kW	78100
8"WPS® 100-20				
Screen Ø210 x 192	1.4301 - AISI 304	Screen for shroud Ø210 mm		78300
Screen Ø256 x 325	1.4301 - AISI 304	Screen for shroud Ø256 mm		78310

Set of 2 supports for shroud Ø210 mm	1.4301 - AISI 304	78400
Set of 3 supports for shroud Ø210 mm	1.4301 - AISI 304	78410
Set of 2 supports for shroud Ø256 mm	1.4301 - AISI 304	78420
Set of 3 supports for shroud Ø256 mm	1.4301 - AISI 304	78430

Cooling schrouds in material 1.4401 - AISI 316 are available upon request

* not suitable for horizontal installation

General Data

All the internal and external metal components of the 10" WPS® pumps are constructed of stainless steel AISI 304 - 1.4301 or AISI 316 - 1.4401 throughout. The suction interconnector and discharge chamber are casted.

10" WPS® submersible pumps are suitable for both continuous and intermittent operation for a variety of applications:

- General water supply
- Waterworks and fountains
- Irrigation
- Tank applications
- Pressure boosting
- Heating pumps
- Dewatering, mining and other industrial applications

Note: For other applications, please contact Well Pumps.

Pump and motor range

10" WPS® pump range consists of three flow models: 120, 155, 220, 260 and 300 m³/h. The pump-end is entirely made out of Stainless Steel DIN 1.4301, AISI 304 or DIN 1.4401, AISI 316.

The pumps are standard equipped with a 6" motor up to 30kW, a 8" submersible motor from 37kW up to 83kW power, 10" motor from 93kW up to 185kW and 12" motor from 220 and 250kW.



Specifications of the pump

The 10" WPS® pump have a capacity up to 350 m³/h and a maximum head of 450m.

The rotation is counter clockwise when looking into the discharge.

Coupling to the motor following NEMA standard.

The 10" WPS® pumps can run continuously in vertical or horizontal position.

Overall diameter of the pump is maximum 247 mm and thus fits into 10" or larger drilled wells.

Pipe connection

All pump types have a treaded pipe connection:

10" WPS® 120: Rp 6"

10" WPS® 155: Rp 6"

10" WPS® 220: Rp 6"

10" WPS® 260: Rp 6"

10" WPS® 300: Rp 6"

A discharge adaptor to flange or other thread is available on request.

Pump identification code

Example

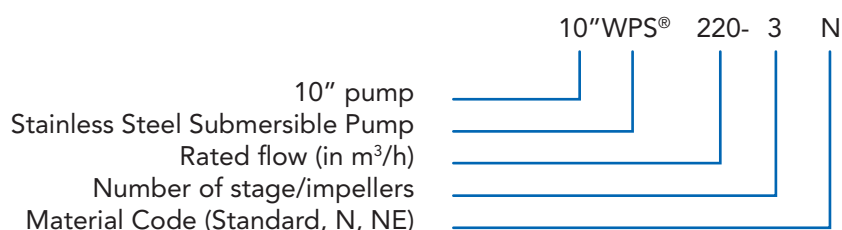

Pumped liquids

10"WPS® submersible pumps are designed for pumping thin, clean, non-aggressive and non-explosive liquids, not containing solid particles.

10"WPS® pumps are suitable for pumping liquids with a content of sand up to 50 g/m³. A higher content of sand will shorten pump life.

The maximum fluid temperature is 25°C. For higher temperatures, please contact Well Pumps.

Construction features

- Coupling and motor flange of pump-end are suitable for connection to motors in accordance with NEMA standard.
- Jam free spring loaded check valve, built in the discharge chamber, is designed for low loss of head.
- Generously dimensioned intermediate bearing located at each stage of the pump in order to perfectly align the shaft and optimize the lubrication.
- Hydraulic profiles are optimized for the attainment of high efficiencies.
- Resistance to corrosion and abrasion, i.e. the same inherent qualities of stainless steel (AISI 304 - 1.4301 or AISI 316 - 1.4401). Models 10"WPS® 260 and 10"WPS® 300 are also available in Duplex steel.
- Great ease of dismantling and assembly.

Curve Conditions

- Curve tolerances according to ISO 9906, 2012 Class 3B.
- The performance curves show pump performance at actual speed of the standard motor range.
- The measurements were made with airless water at a temperature of 20°C and a kinematic viscosity of 1 mm²/s (1 cSt). For pumping liquids with a higher density than clear water, motors must be used with correspondingly higher outputs.
- Q/H: The curves are inclusive of valve and inlet losses at the actual speed.
- Power curve: P₂ shows pump input power at the actual speed for each individual pump size.
- Efficiency curve: η shows pump efficiency.

Service

The pump and motor are very easy to maintain and repair. The modular pump and motor design facilitates installation and service.

Performance Curves

Performance Curves 10"WPS® 120 and 10"WPS® 120 N(E)

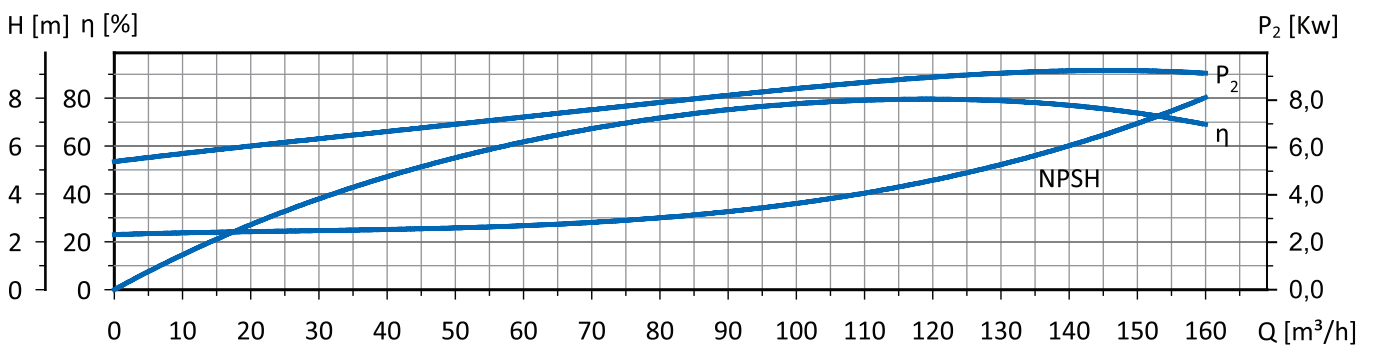
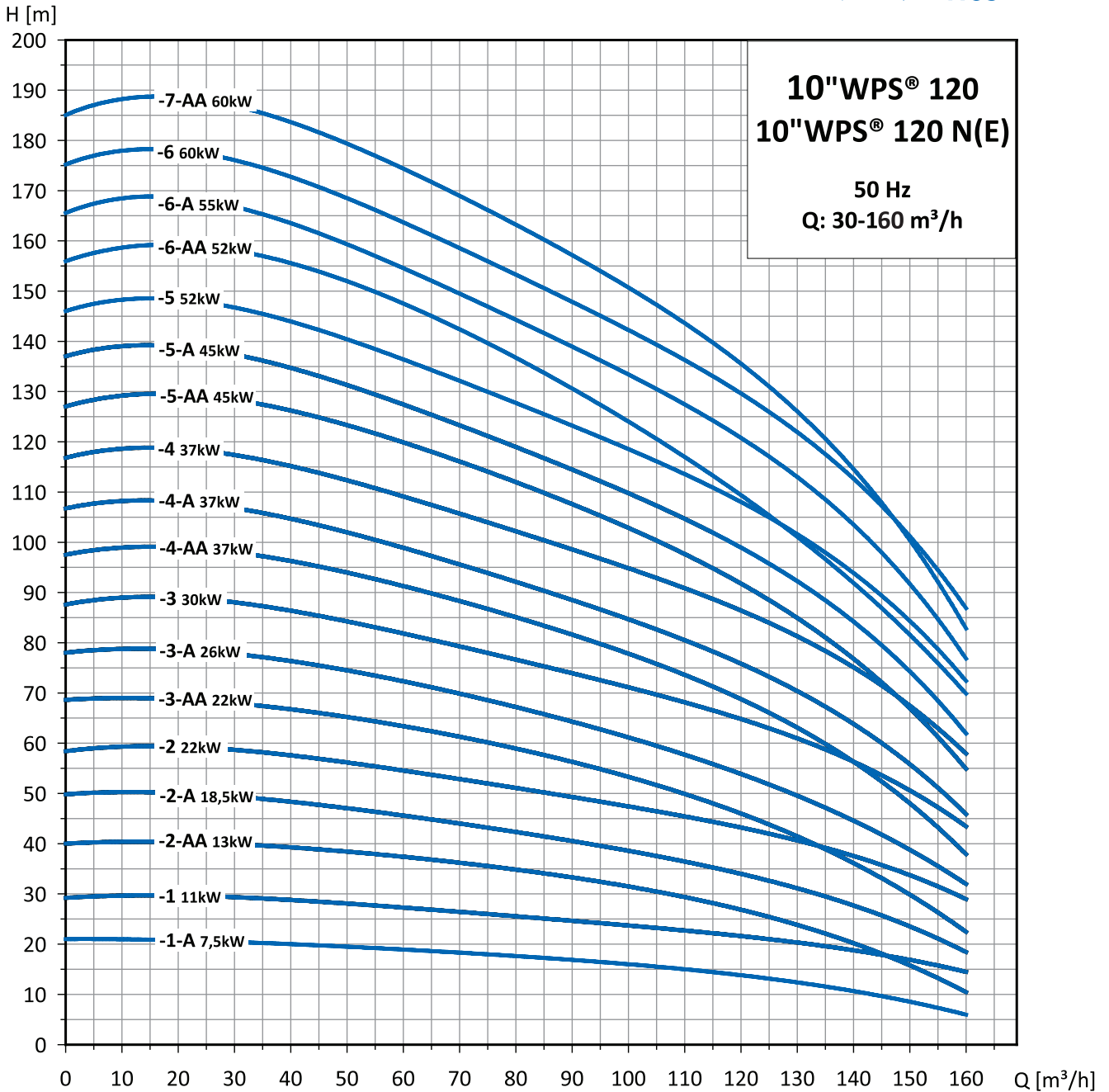

Curves Tolerances according to ISO 9906:2012 Grade 3B

Performance Curves 10"WPS® 120 and 10"WPS® 120 N(E)

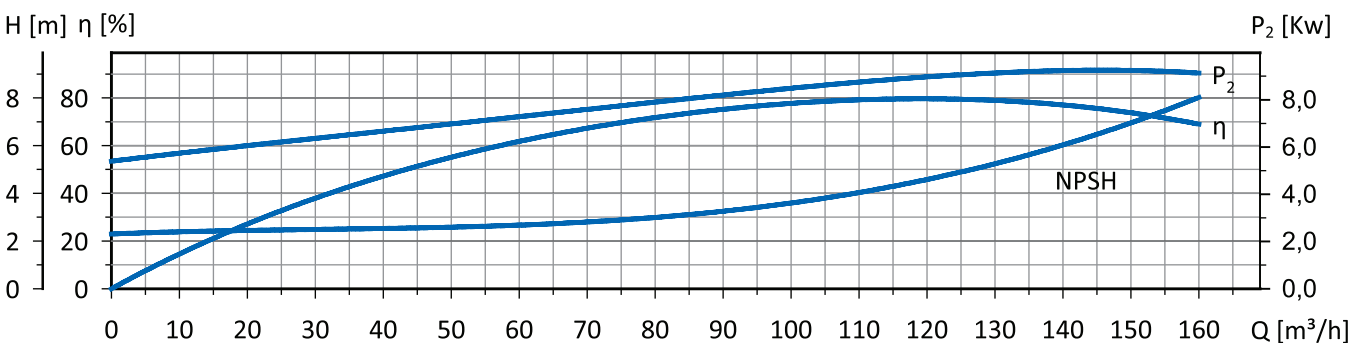
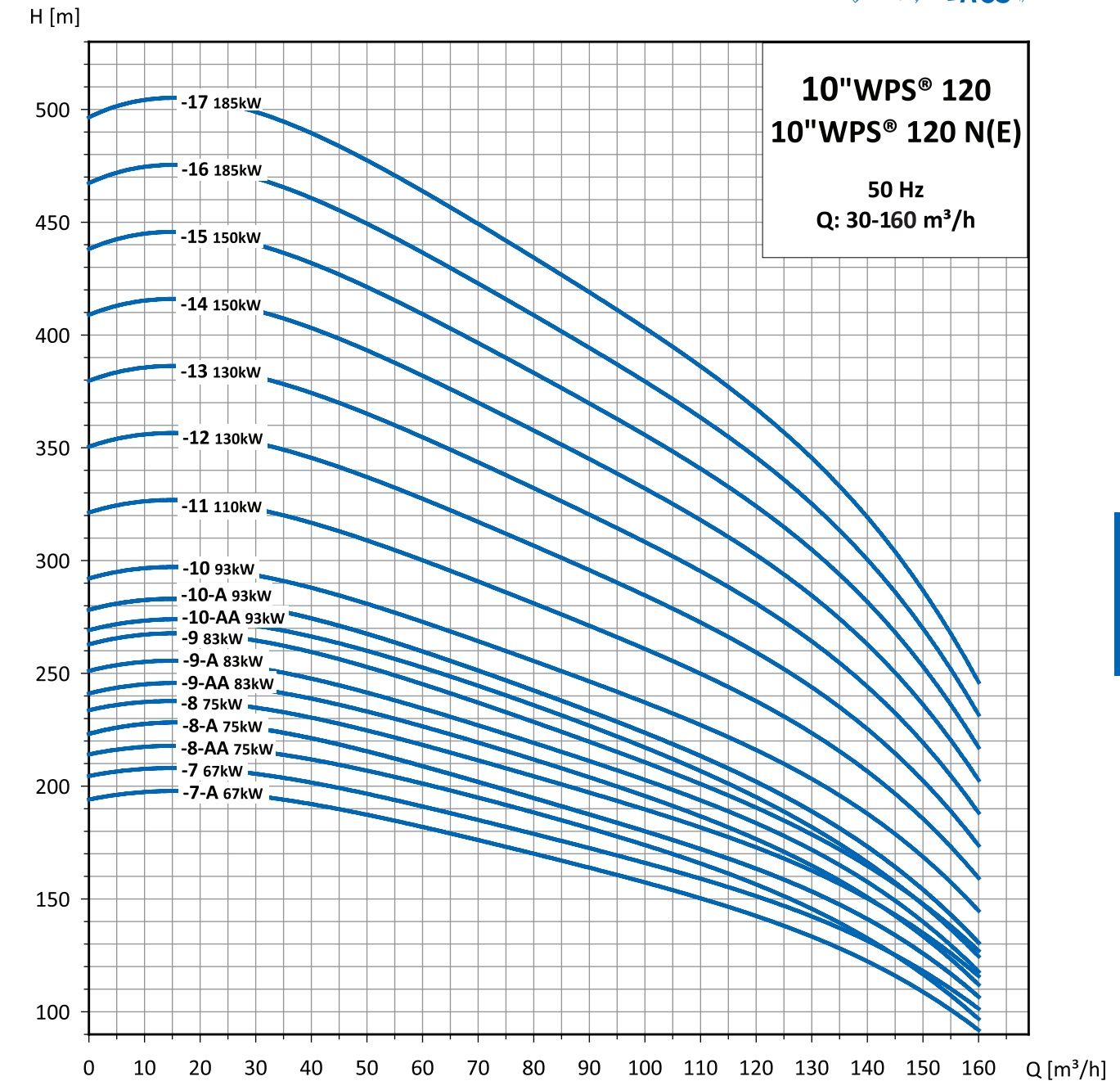

Technical Data

Selection Chart 10"WPS® 120 and 10"WPS® 120 N(E)

Pump Type	Pump Power P ₂		Flow [m ³ /h]								Full load current
	[kW]	[HP]	0	40	60	80	100	120	140	160	3x400V
10"WPS® 120-1-A	7,5	10,0	21	20	19	18	16	14	11	6	15,0
10"WPS® 120-1	11,0	15,0	29	29	27	26	24	22	19	15	21,5
10"WPS® 120-2-AA	13,0	17,5	40	40	37	35	32	27	20	11	29,3
10"WPS® 120-2-A	18,5	25,0	50	49	46	42	39	34	28	19	36,0
10"WPS® 120-2	22,0	30,0	58	58	55	51	47	43	37	29	42,5
10"WPS® 120-3-AA	22,0	30,0	69	67	63	59	54	46	36	23	44,9
10"WPS® 120-3-A	26,0	35,0	78	77	72	68	61	54	45	32	53,0
10"WPS® 120-3	30,0	40,0	88	86	82	77	71	65	56	44	61,0
10"WPS® 120-4-AA	37,0	50,0	98	97	91	85	78	69	56	38	73,0
10"WPS® 120-4-A	37,0	50,0	107	105	99	92	85	76	64	46	74,0
10"WPS® 120-4	37,0	50,0	117	115	109	102	95	87	75	58	78,0
10"WPS® 120-5-AA	45,0	60,0	127	127	120	112	103	92	77	55	88,0
10"WPS® 120-5-A	45,0	60,0	137	135	127	119	110	99	84	62	91,0
10"WPS® 120-5	52,0	70,0	146	144	137	128	119	109	94	73	92,0
10"WPS® 120-6-AA	52,0	70,0	156	156	147	137	127	104	96	69	102,0
10"WPS® 120-6-A	55,0	75,0	166	164	154	144	134	121	103	77	110,0
10"WPS® 120-6	60,0	80,0	175	173	164	153	142	130	112	87	109,0
10"WPS® 120-7-AA	60,0	80,0	185	184	174	163	151	136	114	83	114,0
10"WPS® 120-7-A	67,0	90,0	194	192	182	170	157	143	122	92	125,0
10"WPS® 120-7	67,0	90,0	204	202	191	179	166	152	131	102	131,0
10"WPS® 120-8-AA	75,0	100,0	214	212	201	188	174	157	132	97	137,0
10"WPS® 120-8-A	75,0	100,0	223	222	208	194	181	164	140	107	142,0
10"WPS® 120-8	75,0	100,0	234	230	218	204	190	174	150	116	148,0
10"WPS® 120-9-AA	83,0	111,0	241	239	226	212	196	176	151	109	150,0
10"WPS® 120-9-A	83,0	111,0	251	248	234	219	203	184	157	118	155,0
10"WPS® 120-9	83,0	111,0	263	259	246	228	211	190	165	127	160,0
10"WPS® 120-10-AA	93,0	125,0	269	267	252	235	218	196	165	125	167,0
10"WPS® 120-10-A	93,0	125,0	278	275	259	242	224	203	172	131	175,0
10"WPS® 120-10	93,0	125,0	292	288	273	255	237	217	187	145	182,0
10"WPS® 120-11	110,0	150,0	321	319	300	281	261	239	206	160	222,0
10"WPS® 120-12	130,0	175,0	350	346	328	306	284	260	224	174	225,0
10"WPS® 120-13	130,0	175,0	380	374	355	332	308	282	243	189	245,0
10"WPS® 120-14	150,0	200,0	409	403	382	357	332	304	262	203	271,0
10"WPS® 120-15	150,0	200,0	438	432	410	383	356	326	281	218	283,0
10"WPS® 120-16	185,0	240,0	467	461	437	408	379	347	299	232	327,0
10"WPS® 120-17	185,0	240,0	496	490	464	434	403	369	318	247	355,0

10"WPS®

Dimensions and Weights 10"WPS® 120 and 10"WPS® 120 N(E)

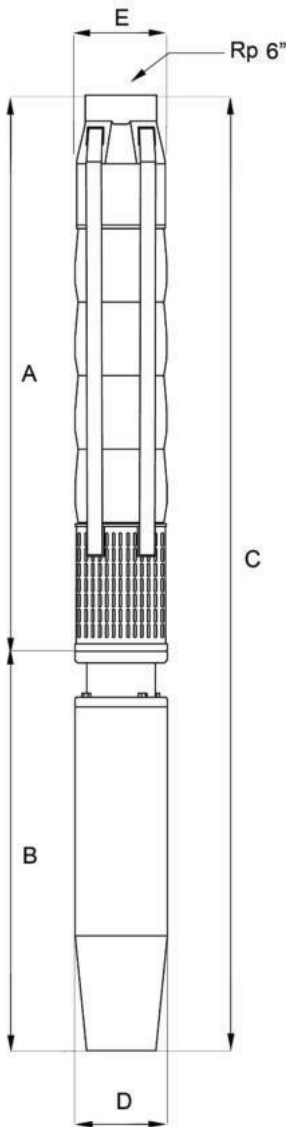

Pump Type	A [mm]	B [mm]	C [mm]	D [mm]	E [mm]	E* [mm]	Motor Type	Weight [kg]	
								Pump end	Electropump
10"WPS® 120-1-A	652	649	1298	137	211	218	6"	29,2	75,2
10"WPS® 120-1	652	711	1363	137	211	218	6"	29,3	81,0
10"WPS® 120-2-AA	807	809	1616	154	211	218	6"	35,6	91,6
10"WPS® 120-2-A	807	842	1649	137	211	218	6"	35,7	99,8
10"WPS® 120-2	807	907	1714	137	211	218	6"	35,8	105,9
10"WPS® 120-3-AA	963	907	1870	137	211	218	6"	42,1	112,2
10"WPS® 120-3-A	963	1094	2057	145	211	218	6"	42,2	127,2
10"WPS® 120-3	963	1037	2000	137	211	218	6"	42,3	127,0
10"WPS® 120-3	963	1140	2103	194	213	227	8"	47,1	187,1
10"WPS® 120-4-AA	1118	1037	2155	137	211	218	6"	48,6	133,3
10"WPS® 120-4-AA	1118	1140	2258	194	213	227	8"	51,9	191,9
10"WPS® 120-4-A	1118	1274	2392	145	211	218	6"	48,7	150,7
10"WPS® 120-4-A	1118	1140	2258	194	213	227	8"	52,0	192,0
10"WPS® 120-4	1118	1274	2392	145	211	218	6"	48,8	150,8
10"WPS® 120-4	1118	1140	2258	194	213	227	8"	52,1	192,1
10"WPS® 120-5-AA	1274	1274	2548	145	211	218	6"	55,1	157,1
10"WPS® 120-5-AA	1274	1140	2414	194	213	227	8"	56,9	169,9
10"WPS® 120-5-A	1274	1629	2903	137	211	218	6"	55,2	206,2
10"WPS® 120-5-A	1274	1230	2504	194	213	227	8"	57,0	213,0
10"WPS® 120-5	1274	1230	2504	194	213	227	8"	57,1	213,1
10"WPS® 120-6-AA	1429	1340	2769	194	213	227	8"	61,9	240,9
10"WPS® 120-6-A	1429	1340	2769	194	218	227	8"	62,0	241,0
10"WPS® 120-6	1429	1470	2899	194	218	227	8"	62,1	260,1
10"WPS® 120-7-AA	1585	1470	3055	194	218	227	8"	66,9	264,9
10"WPS® 120-7-A	1585	1470	3055	194	218	227	8"	67,0	265,0
10"WPS® 120-7	1585	1470	3055	194	218	227	8"	67,1	265,1
10"WPS® 120-8-AA	1740	1560	3300	194	218	227	8"	71,9	286,9
10"WPS® 120-8-A	1740	1560	3300	194	218	227	8"	72,0	287,0
10"WPS® 120-8	1740	1560	3300	194	218	227	8"	72,1	287,1
10"WPS® 120-9-AA	1896	1740	3636	194	218	227	8"	76,9	323,9
10"WPS® 120-9-AA	1896	1419	3315	235	227	247	10"	76,9	356,9
10"WPS® 120-9-A	1896	1740	3636	194	218	227	8"	77,0	324,0
10"WPS® 120-9-A	1896	1419	3315	235	227	247	10"	77,0	357,0
10"WPS® 120-9	1896	1740	3636	194	218	227	8"	77,1	324,1
10"WPS® 120-9	1896	1419	3315	235	227	247	10"	77,1	257,1
10"WPS® 120-10-AA	2051	1740	3791	194	218	227	8"	81,9	328,9
10"WPS® 120-10-AA	2051	1419	3470	235	227	247	10"	81,9	361,9
10"WPS® 120-10-A	2051	1740	3791	194	218	227	8"	82,0	329,0
10"WPS® 120-10-A	2051	1419	3470	235	227	247	10"	82,0	362,0
10"WPS® 120-10	2051	1976	4027	194	218	227	8"	82,1	460,1
10"WPS® 120-10	2051	1529	3580	235	227	247	10"	82,1	397,1
10"WPS® 120-11	2207	1976	4183	191	218	227	8"	87,1	465,1
10"WPS® 120-11	2207	1529	3736	235	227	247	10"	87,1	402,1
10"WPS® 120-12	2492	2179	4671	191	218	227	8"	109,5	529,5
10"WPS® 120-12	2492	1659	4551	235	227	247	10"	109,5	471,5
10"WPS® 120-13	2648	2179	4827	191	218	227	8"	116,0	536,0
10"WPS® 120-13	2648	1659	4307	235	227	247	10"	116,0	478,0
10"WPS® 120-14	2803	2401	5204	291	227	-	8"	122,5	616,5
10"WPS® 120-14	2803	1769	4572	235	-	247	10"	122,5	535,5
10"WPS® 120-15	2959	2401	5360	191	227	-	8"	129,0	623,0
10"WPS® 120-15	2959	1769	4728	235	-	247	10"	129,0	542,0
10"WPS® 120-16	3114	1919	5033	235	-	247	10"	135,5	584,5
10"WPS® 120-17	3270	1919	5189	235	-	247	10"	142,0	591,0

* With 2 cable guards

Performance Curves

Performance Curves 10"WPS® 155 and 10"WPS® 155 N(E)

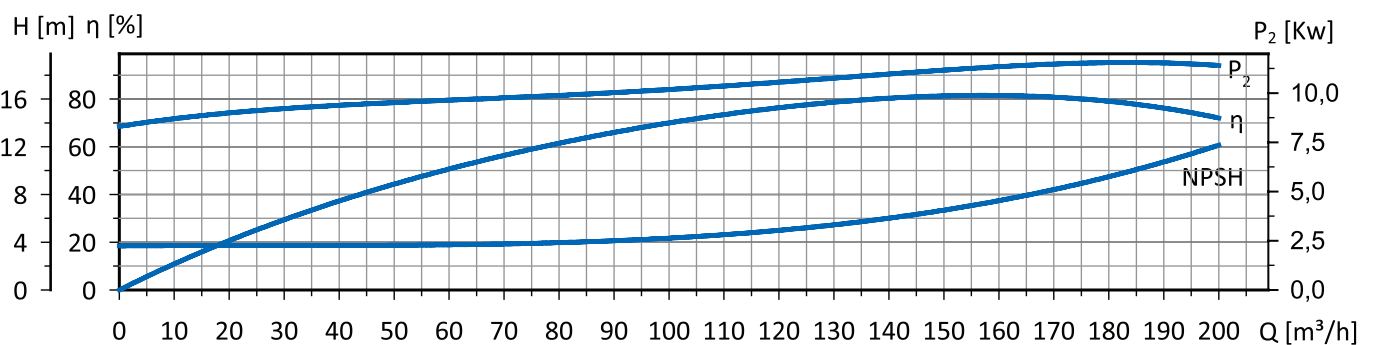
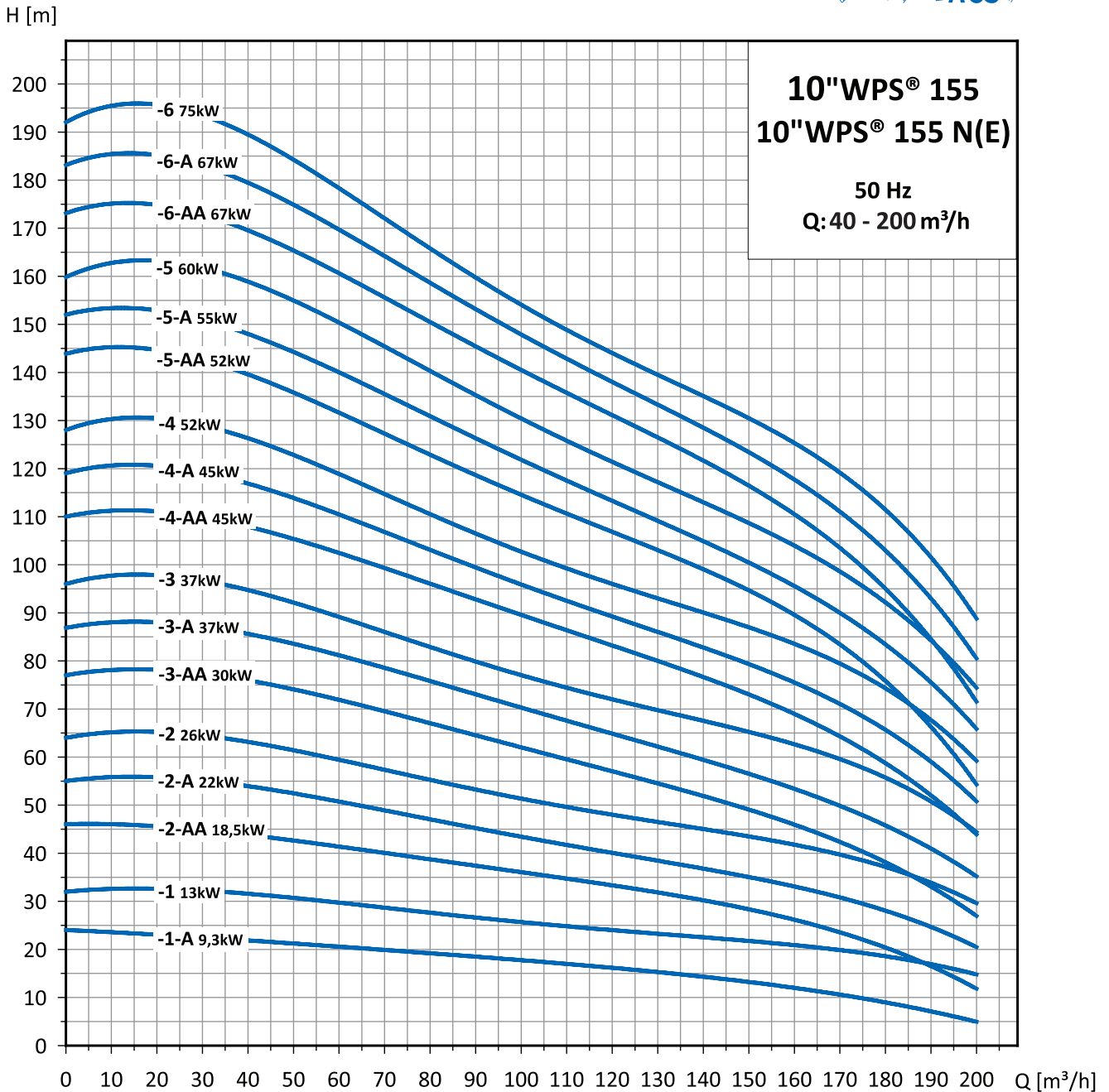

Curves Tolerances according to ISO 9906:2012 Grade 3B

Performance Curves 10"WPS® 155 and 10"WPS® 155 N(E)

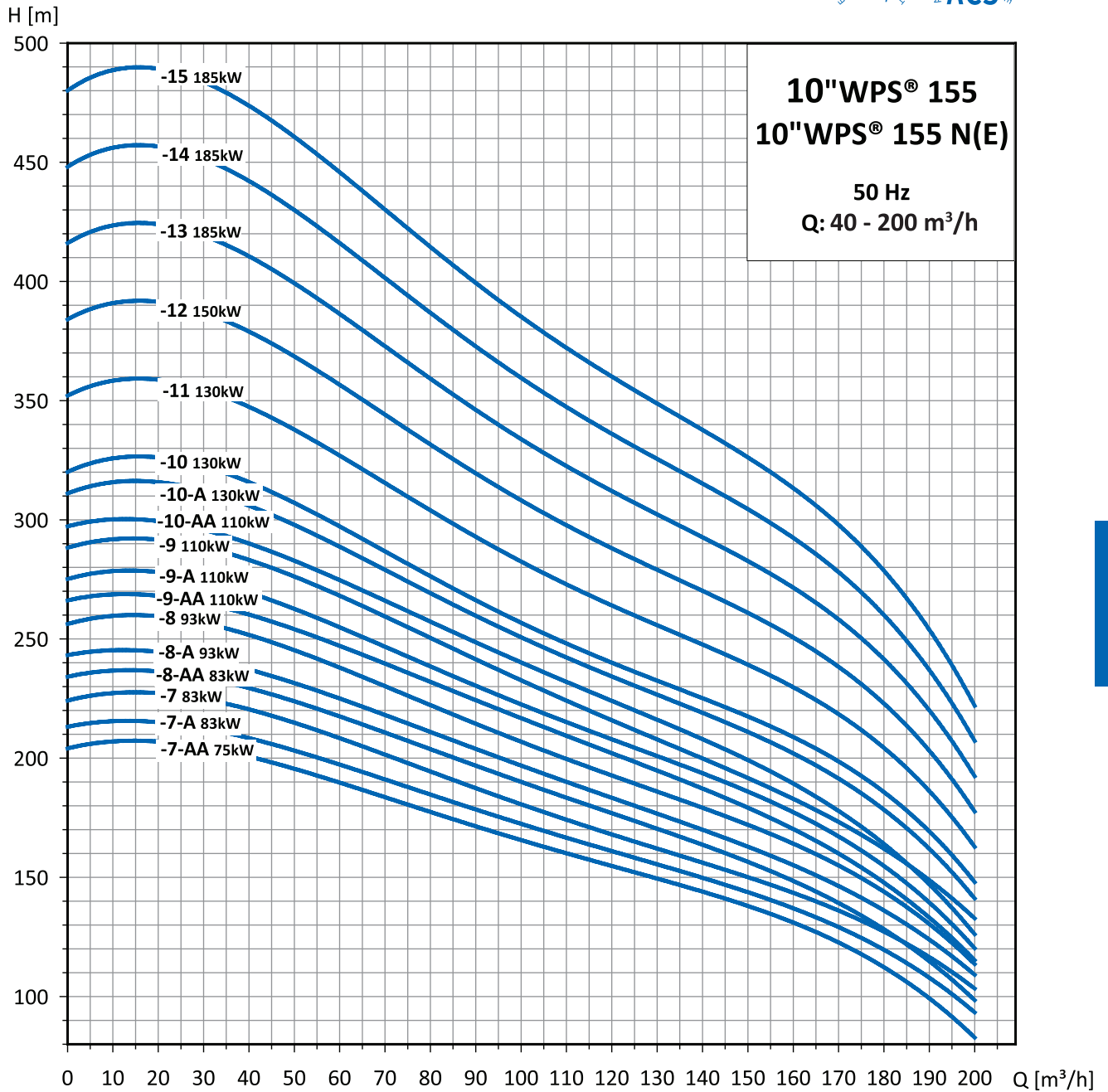

10"WPS®

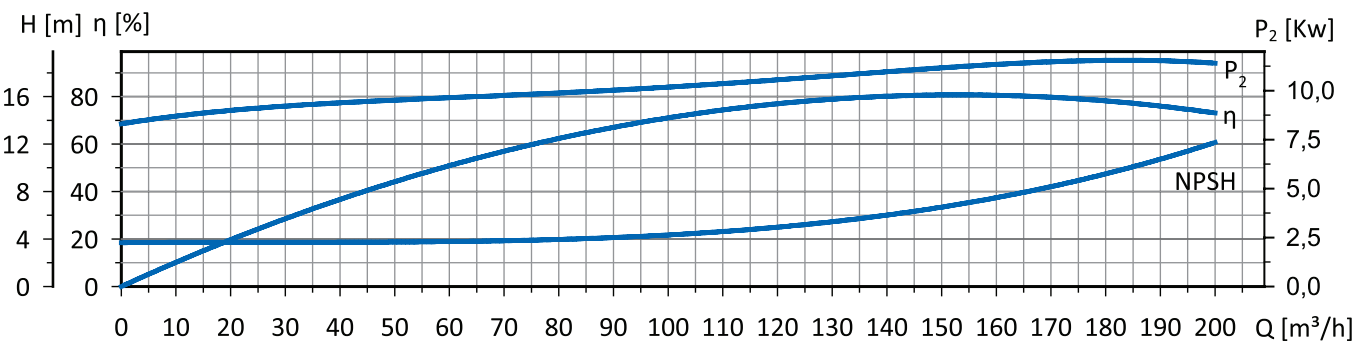

Technical Data

Selection Chart 10"WPS® 155 and 10"WPS® 155 N(E)

Pump Type	Pump Power P ₂		Flow [m ³ /h]								Full load current
	[kW]	[HP]	0	40	80	120	140	160	180	200	3x400V
10"WPS® 155-1-A	9,3	12,5	24	22	19	16	15	12	9	5	20,5
10"WPS® 155-1	13	17,5	32	32	28	24	23	21	19	15	29,3
10"WPS® 155-2-AA	18,5	25	46	44	39	33	31	26	20	12	36
10"WPS® 155-2-A	22	30	55	54	47	40	37	33	28	21	44
10"WPS® 155-2	26	35	64	63	55	48	45	42	37	30	53,3
10"WPS® 155-3-AA	30	40	77	76	67	57	52	46	38	27	61
10"WPS® 155-3-A	37	50	87	85	77	64	59	54	46	35	73
10"WPS® 155-3	37	50	96	95	83	72	68	62	56	44	79
10"WPS® 155-4-AA	45	60	110	108	96	83	77	69	59	44	85
10"WPS® 155-4-A	45	60	119	117	103	89	83	76	65	51	93
10"WPS® 155-4	52	70	128	126	110	96	90	83	74	59	93
10"WPS® 155-5-AA	52	70	144	139	124	106	99	90	77	54	103
10"WPS® 155-5-A	55	75	152	148	131	113	105	96	83	66	110
10"WPS® 155-5	60	80	160	158	142	120	113	104	93	74	113
10"WPS® 155-6-AA	67	90	173	170	150	130	124	110	94	72	120
10"WPS® 155-6-A	67	90	183	180	158	137	131	117	102	81	133
10"WPS® 155-6	75	100	192	190	166	144	136	125	112	89	135
10"WPS® 155-7-AA	75	100	204	201	177	154	146	130	112	83	145
10"WPS® 155-7-A	83	111	213	209	184	160	152	137	118	94	149
10"WPS® 155-7	83	111	224	221	193	168	158	142	127	104	155
10"WPS® 155-8-AA	83	111	234	230	203	176	166	148	127	99	160
10"WPS® 155-8-A	93	125	243	238	210	182	173	155	134	110	170
10"WPS® 155-8	93	125	256	253	221	192	181	166	140	115	183
10"WPS® 155-9-AA	110	150	266	261	231	201	190	170	146	116	201
10"WPS® 155-9-A	110	150	275	270	238	206	197	177	153	121	208
10"WPS® 155-9	110	150	288	284	248	216	203	180	162	133	216
10"WPS® 155-10-AA	110	150	297	291	256	223	211	189	162	127	223
10"WPS® 155-10-A	130	175	311	306	270	230	224	202	176	142	225
10"WPS® 155-10	130	175	320	316	276	240	226	208	186	148	240
10"WPS® 155-11	130	175	352	348	304	264	249	229	205	163	255
10"WPS® 155-12	150	200	384	379	331	288	271	250	223	178	288
10"WPS® 155-13	185	250	416	411	359	312	294	270	242	192	325
10"WPS® 155-14	185	250	448	442	386	336	316	291	260	207	342
10"WPS® 155-15	185	250	480	474	414	360	339	312	279	222	360

10"WPS®

Dimensions and Weights 10"WPS® 155 and 10"WPS® 155 N(E)

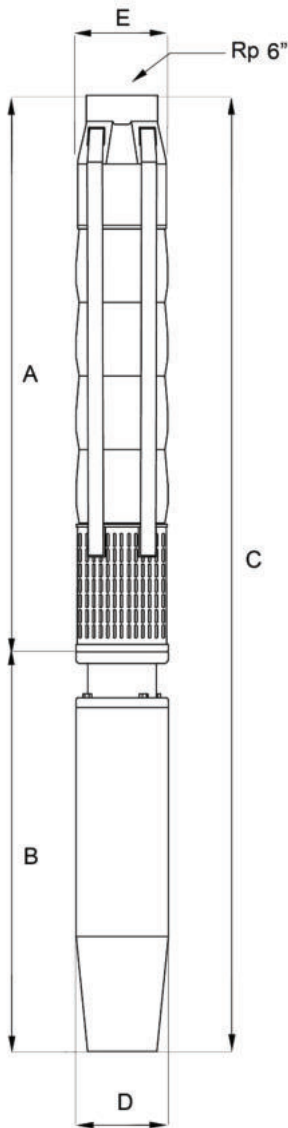

Pump Type	A [mm]	B [mm]	C [mm]	D [mm]	E [mm]	E* [mm]	Motor Type	Weight [kg]	
								Pump end	Electropump
10"WPS® 155-1-A	652	679	1331	137	211	218	6"	30,4	78,7
10"WPS® 155-1	652	809	1461	145	211	218	6"	30,4	86,4
10"WPS® 155-2-AA	807	842	1649	137	211	218	6"	36,7	100,8
10"WPS® 155-2-A	807	907	1714	137	211	218	6"	36,8	106,9
10"WPS® 155-2	807	1094	1901	145	211	218	6"	36,8	121,8
10"WPS® 155-3-AA	963	1037	2000	137	211	218	6"	43,2	127,9
10"WPS® 155-3-AA	963	1140	2103	194	218	227	8"	43,2	183,2
10"WPS® 155-3-A	963	1274	2237	145	211	218	6"	43,2	145,2
10"WPS® 155-3-A	963	1140	2103	194	218	227	8"	43,2	183,2
10"WPS® 155-3	963	1274	2237	145	211	218	6"	43,2	145,2
10"WPS® 155-3	963	1140	2103	194	218	227	8"	43,2	183,2
10"WPS® 155-4-AA	1118	1629	2747	137	211	218	6"	50,9	201,9
10"WPS® 155-4-AA	1118	1230	2348	144	218	227	8"	50,9	206,9
10"WPS® 155-4-A	1118	1629	2747	137	211	218	6"	51	202
10"WPS® 155-4-A	1118	1274	2392	145	218	227	8"	51	207
10"WPS® 155-4	1118	1340	2458	194	218	227	8"	51	230
10"WPS® 155-5-AA	1274	1340	2614	194	218	227	8"	57,3	236,3
10"WPS® 155-5-A	1274	1340	2614	194	218	227	8"	57,4	236,4
10"WPS® 155-5	1274	1470	2744	194	218	227	8"	57,4	255,4
10"WPS® 155-6-AA	1429	1470	2899	194	218	227	8"	63,7	261,7
10"WPS® 155-6-A	1429	1470	2899	194	218	227	8"	63,8	261,8
10"WPS® 155-6	1429	1560	2989	194	218	227	8"	63,8	278,8
10"WPS® 155-7-AA	1585	1560	3145	194	218	227	8"	70,2	285,2
10"WPS® 155-7-A	1585	1740	3325	194	218	227	8"	70,2	317,2
10"WPS® 155-7-A	1585	1419	3004	235	227	247	10"	70,2	350,2
10"WPS® 155-7	1585	1740	3325	194	218	227	8"	70,2	317,2
10"WPS® 155-7	1585	1419	3004	235	227	247	10"	70,2	350,2
10"WPS® 155-8-AA	1740	1740	3480	194	218	227	8"	76,6	323,6
10"WPS® 155-8-AA	1740	1419	3159	235	227	247	10"	76,6	356,6
10"WPS® 155-8-A	1740	1740	3480	194	218	227	8"	76,7	323,7
10"WPS® 155-8-A	1740	1419	3159	235	227	247	10"	76,7	356,7
10"WPS® 155-8	1740	1740	3480	194	218	227	8"	76,7	323,7
10"WPS® 155-8	1740	1419	3159	235	227	247	10"	76,7	356,7
10"WPS® 155-9-AA	1896	1976	3872	194	218	227	8"	83	461
10"WPS® 155-9-AA	1896	1529	3425	235	227	247	10"	83	398
10"WPS® 155-9-A	1896	1976	3872	191	218	227	8"	83,1	461,1
10"WPS® 155-9-A	1896	1529	3425	235	227	247	10"	83,1	398,1
10"WPS® 155-9	1896	1976	3872	191	218	227	8"	83,1	461,1
10"WPS® 155-9	1896	1529	3425	235	227	247	10"	83,1	398,1
10"WPS® 155-10-AA	2051	1976	4027	191	218	227	8"	89,4	467,4
10"WPS® 155-10-AA	2051	1529	3580	235	227	247	10"	89,4	404,4
10"WPS® 155-10-A	2181	2779	4360	191	218	227	8"	102,6	522,6
10"WPS® 155-10-A	2181	1659	3840	235	227	247	10"	102,6	464,6
10"WPS® 155-10	2181	2179	4360	191	218	227	8"	102,6	522,6
10"WPS® 155-10	2181	1659	3840	235	227	247	10"	102,6	464,6
10"WPS® 155-11	2337	2179	4516	191	218	227	8"	109,0	529,0
10"WPS® 155-11	2337	1659	3996	235	227	247	10"	109	471
10"WPS® 155-12	2492	2408	4900	191	218	-	8"	115,5	609,5
10"WPS® 155-12	2492	1769	4261	235	-	247	10"	115,5	528,5
10"WPS® 155-13	2648	1919	4567	235	-	247	10"	121,9	570,9
10"WPS® 155-14	2803	1919	4722	235	-	247	10"	128,3	577,3
10"WPS® 155-15	2959	1919	4878	235	-	247	10"	134,7	583,7

* With 2 cable guards

Performance Curves

Performance Curves 10" WPS® 220 and 10" WPS® 220 N(E)

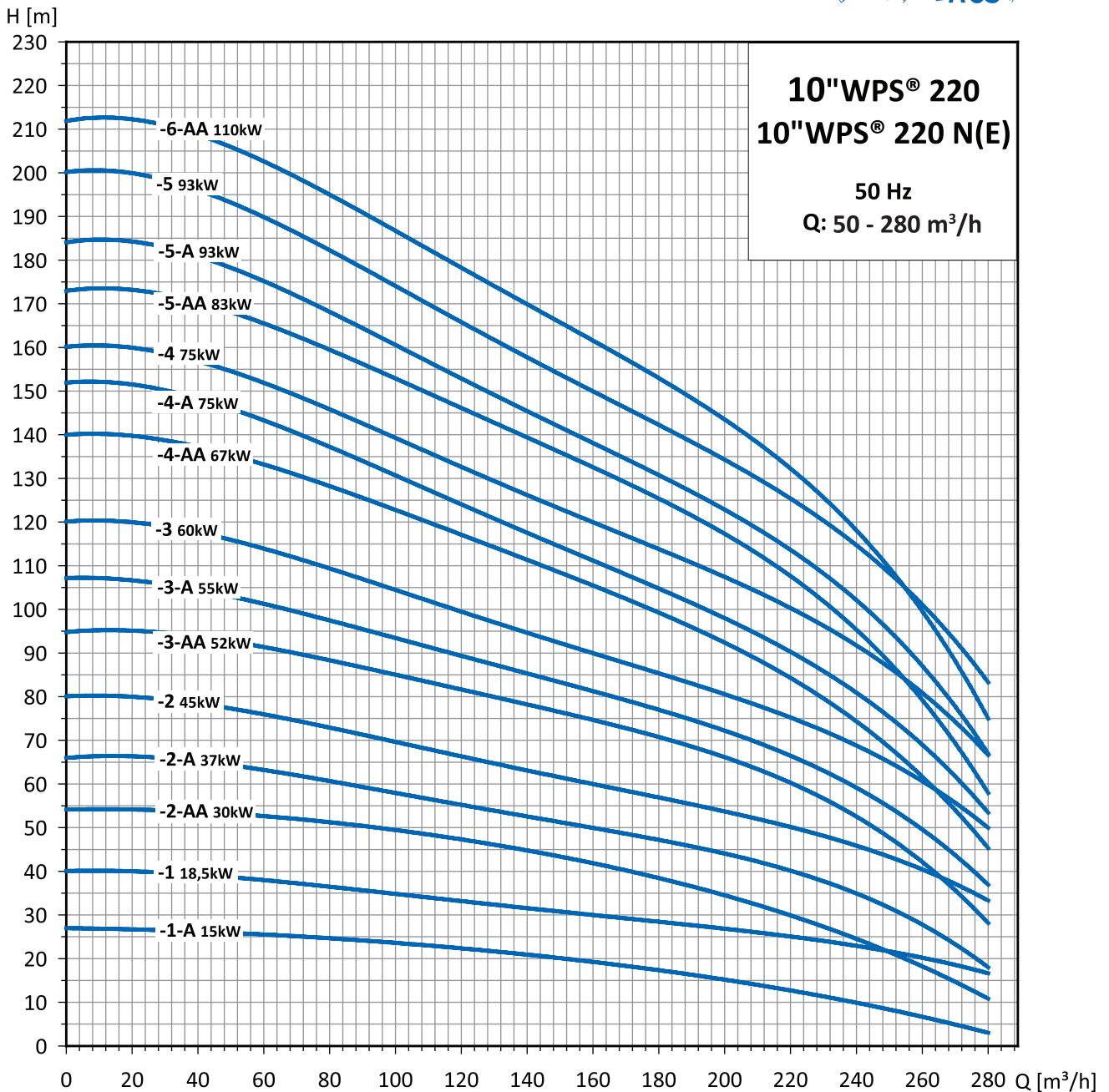

10" WPS®

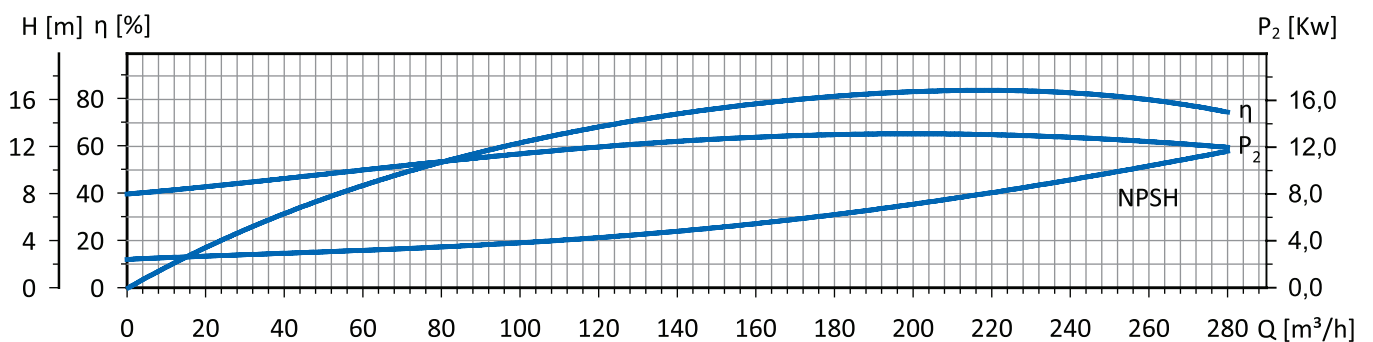

Performance Curves 10"WPS® 220 and 10"WPS® 220 N(E)

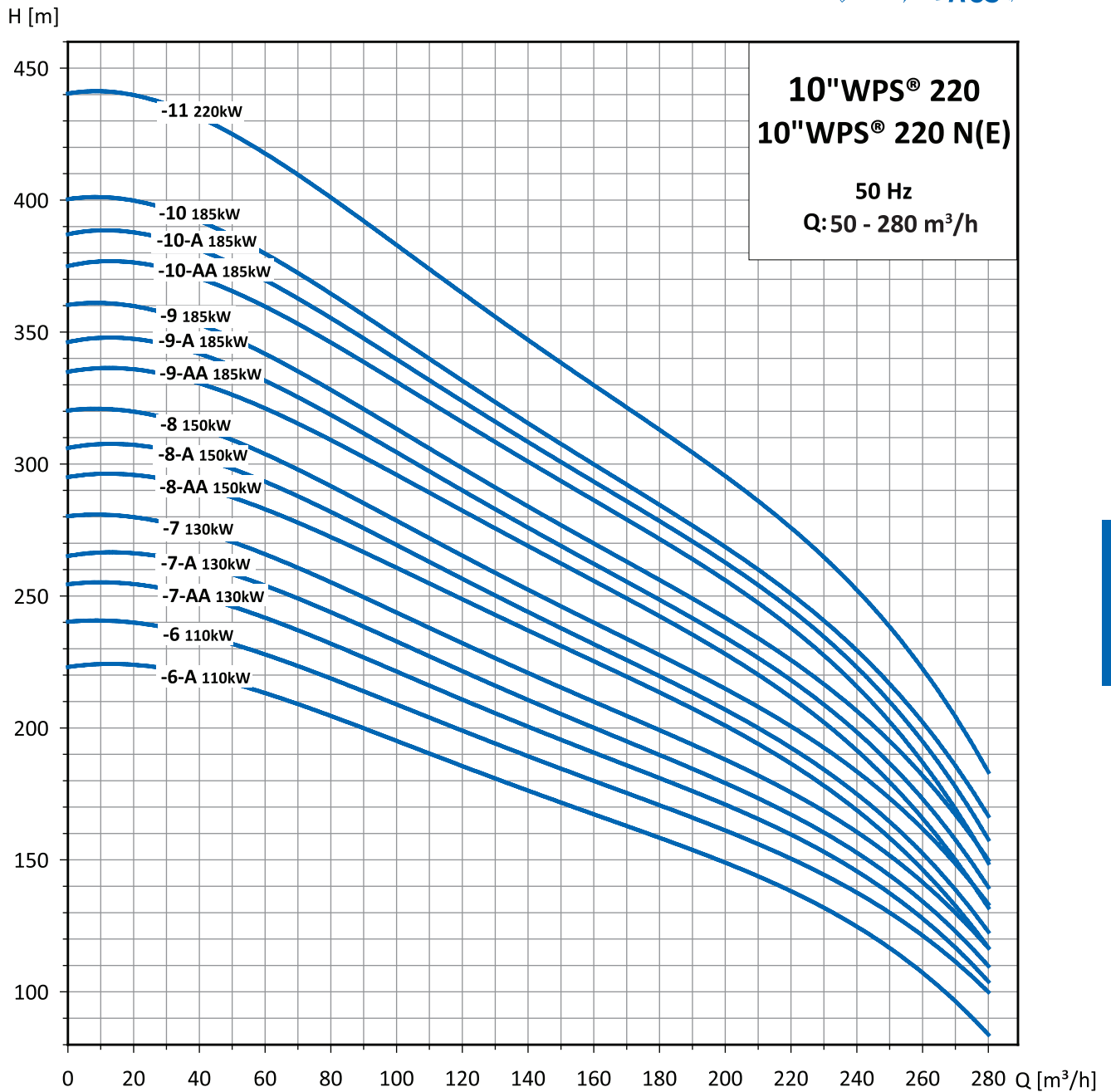

10"WPS®

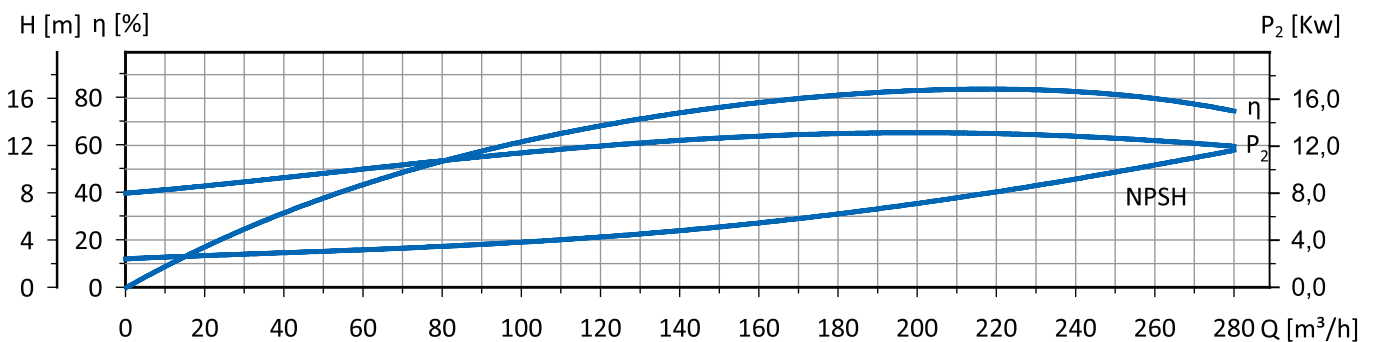

Technical Data

Selection Chart 10"WPS® 220 and 10"WPS® 220 N(E)

Pump Type	Pump Power P ₂		Flow [m ³ /h]								Full load current 3x400V
	[kW]	[HP]	0	40	80	120	160	200	240	280	
10"WPS® 220-1-A	15	20	27	26	25	22	20	15	10	3	31
10"WPS® 220-1	18,5	25	40	39	36	33	30	27	23	17	38
10"WPS® 220-2-AA	30	40	54	54	51	47	42	35	24	11	63
10"WPS® 220-2-A	37	50	66	65	61	55	50	44	35	18	81,9
10"WPS® 220-2	45	60	80	79	73	66	60	54	46	33	93,9
10"WPS® 220-3-AA	52	70	95	93	89	82	74	66	53	28	103
10"WPS® 220-3-A	55	75	107	105	97	89	82	72	59	37	110
10"WPS® 220-3	60	80	120	118	109	99	90	81	68	50	105
10"WPS® 220-4-AA	67	90	141	133	134	115	104	93	75	45	130
10"WPS® 220-4-A	75	100	153	144	143	122	110	98	82	53	133
10"WPS® 220-4	75	100	160	157	146	132	120	108	91	67	148
10"WPS® 220-5-AA	83	111	173	170	160	146	132	118	95	58	158
10"WPS® 220-5-A	93	125	184	181	168	153	138	123	102	67	170
10"WPS® 220-5	93	125	200	197	182	166	150	135	114	84	183
10"WPS® 220-6-AA	110	150	212	208	196	178	161	144	118	75	190
10"WPS® 220-6-A	110	150	223	220	205	185	167	150	124	84	206
10"WPS® 220-6	110	150	240	236	218	199	180	162	137	100	222
10"WPS® 220-7-AA	130	175	254	250	235	204	194	174	142	105	235
10"WPS® 220-7-A	130	175	265	262	244	221	200	180	152	110	245
10"WPS® 220-7	130	175	280	275	255	232	210	189	160	117	256
10"WPS® 220-8-AA	150	200	295	291	273	248	225	202	168	117	275
10"WPS® 220-8-A	150	200	306	302	283	255	232	208	174	123	287
10"WPS® 220-8	150	200	320	314	291	265	240	216	182	134	298
10"WPS® 220-9-AA	185	230	335	330	310	282	255	229	191	132	340
10"WPS® 220-9-A	185	230	346	342	319	289	262	236	197	140	347
10"WPS® 220-9	185	230	360	354	328	298	270	243	205	150	354
10"WPS® 220-10-AA	185	230	375	370	347	315	286	257	215	149	361
10"WPS® 220-10-A	185	230	387	381	356	323	293	264	222	158	368
10"WPS® 220-10	185	230	400	393	364	331	300	270	228	167	375
10"WPS® 220-11	220	300	440	432	400	364	330	297	251	184	384

10"WPS®

Dimensions and Weights 10"WPS® 220 and 10"WPS® 220 N(E)

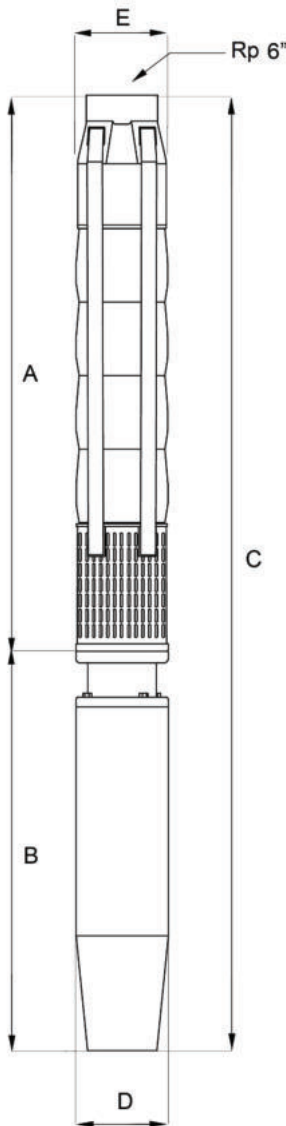

Pump Type	A [mm]	B [mm]	C [mm]	D [mm]	E [mm]	E* [mm]	Motor Type	Weight [kg]	
								Pump end	Electro-pump
10"WPS®220-1-A	772	776	1548	137	237	241	6"	46,1	103,6
10"WPS®220-1	772	842	1613	137	237	241	6"	46,1	110,2
10"WPS®220-2-AA	948	1037	1984	137	237	241	6"	56,1	140,8
10"WPS®220-2-AA	948	1140	2088	194	237	241	8"	56,1	196,1
10"WPS®220-2-A	948	1274	2222	145	237	241	6"	56,1	158,1
10"WPS®220-2-A	948	1140	2088	194	237	241	8"	56,1	196,1
10"WPS®220-2	948	1629	2577	137	237	241	6"	55,8	206,8
10"WPS®220-2	948	1230	2178	194	237	241	8"	55,8	211,8
10"WPS®220-3-AA	1124	1340	2464	194	237	241	8"	65,6	244,6
10"WPS®220-3-A	1124	1340	2464	194	237	241	8"	65,6	244,6
10"WPS®220-3	1124	1470	2594	194	237	241	8"	65,6	254,6
10"WPS®220-4-AA	1230	1470	2770	194	237	241	8"	75,4	273,4
10"WPS®220-4-A	1230	1560	2860	194	237	241	8"	75,4	290,4
10"WPS®220-4	1230	1560	2860	194	237	241	8"	75,4	290,4
10"WPS®220-5-AA	1476	1740	3216	194	237	241	8"	85,8	332,8
10"WPS®220-5-AA	1476	1419	2895	235	262	274	10"	85,8	365,8
10"WPS®220-5-A	1476	1740	3216	194	237	241	8"	85,8	332,8
10"WPS®220-5-A	1476	1419	2895	235	262	274	10"	85,8	365,8
10"WPS®220-5	1476	1976	3452	194	237	241	8"	85,8	463,8
10"WPS®220-5	1476	1529	3005	235	262	274	10"	85,8	400,8
10"WPS®220-6-AA	1652	1976	3628	191	237	241	8"	96,2	477,2
10"WPS®220-6-AA	1652	1529	3181	235	262	274	10"	96,2	411,2
10"WPS®220-6-A	1652	1976	3628	191	237	241	8"	96,2	477,2
10"WPS®220-6-A	1652	1529	3181	235	262	274	10"	96,2	411,2
10"WPS®220-6	1652	1976	3628	191	237	241	8"	96,2	477,2
10"WPS®220-6	1652	1529	3181	235	241	274	10"	96,2	411,2
10"WPS®220-7-AA	1828	2179	4007	191	237	241	8"	111,2	531,2
10"WPS®220-7-AA	1828	1659	3487	235	241	274	10"	111,2	473,2
10"WPS®220-7-A	1828	2179	4007	191	237	241	8"	111,2	531,2
10"WPS®220-7-A	1828	1659	3487	235	241	274	10"	111,2	473,2
10"WPS®220-7	1828	2179	4007	191	237	241	8"	111,2	531,2
10"WPS®220-7	1828	1659	3487	235	241	274	10"	111,2	473,2
10"WPS®220-8-AA	2004	2408	4412	191	237	-	8"	121,5	615,5
10"WPS®220-8-AA	2004	1769	3773	235	-	274	10"	121,5	534,5
10"WPS®220-8-A	2004	2408	4412	191	237	-	8"	121,5	615,5
10"WPS®220-8-A	2004	1769	3773	235	-	274	10"	121,5	534,5
10"WPS®220-8	2004	2408	4412	191	237	-	8"	121,5	615,5
10"WPS®220-8	2004	1769	3773	235	-	274	10"	121,5	534,5
10"WPS®220-9-AA	2198	1919	4099	235	-	274	10"	131,7	580,7
10"WPS®220-9-A	2198	1919	4099	235	-	274	10"	131,7	580,7
10"WPS®220-9	2198	1919	4099	235	-	274	10"	131,7	580,7
10"WPS®220-10-AA	2356	1919	4275	235	-	274	10"	141,9	590,9
10"WPS®220-10-A	2356	1919	4275	235	-	274	10"	141,9	590,9
10"WPS®220-10	2356	1919	4275	235	-	274	10"	141,9	590,9
10"WPS®220-11	2532	1893	4425	286	237	274	12"	152,1	815,1

* With 2 cable guards

Performance Curves

Performance Curves 10"WPS® 260 and 10"WPS® 260 N

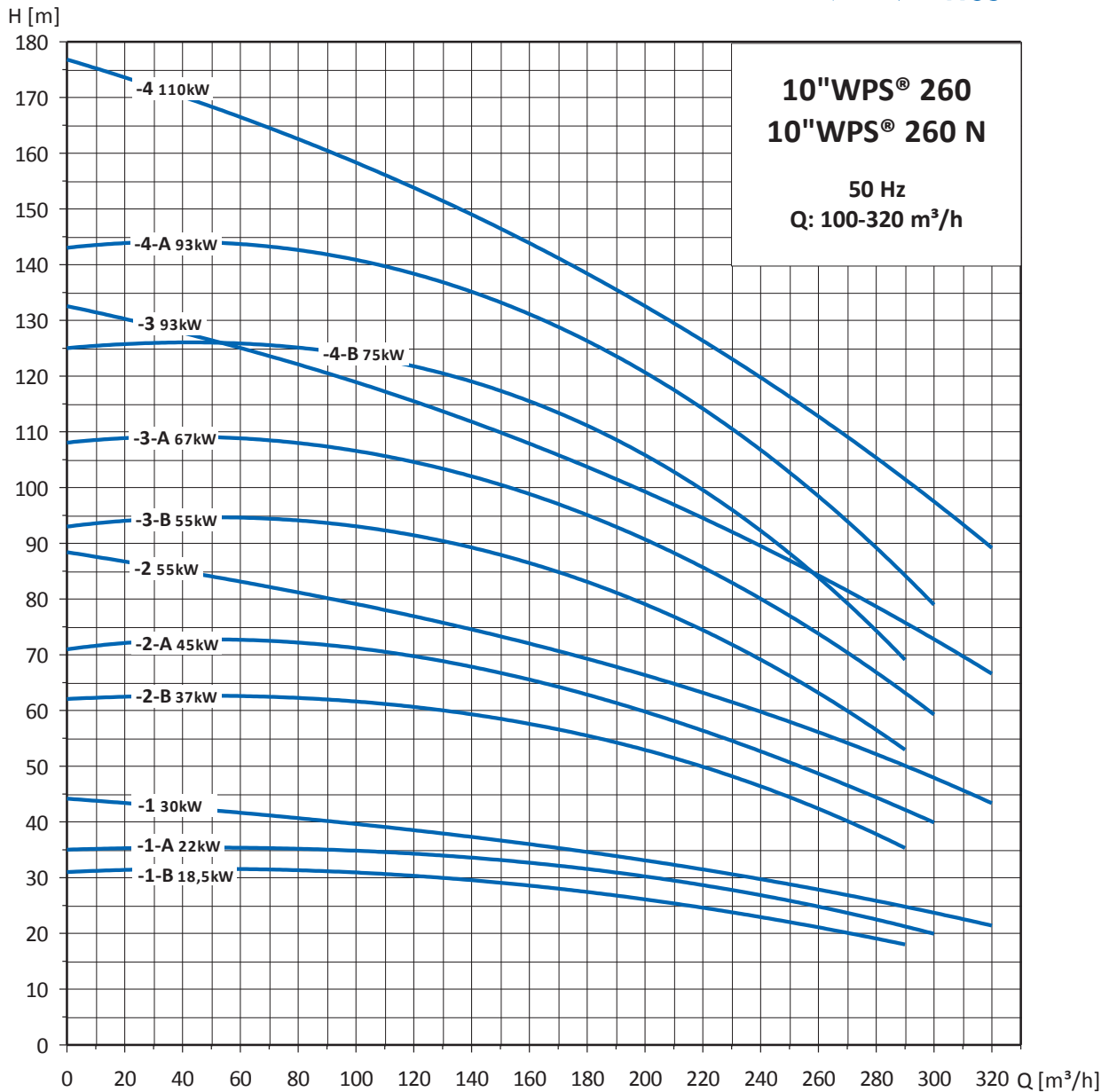

10"WPS®

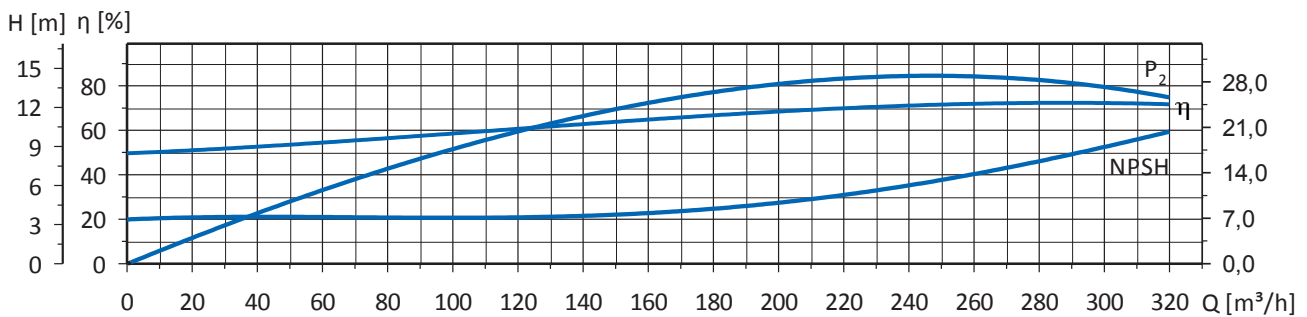

Performance Curves 10"WPS® 260 and 10"WPS® 260 N

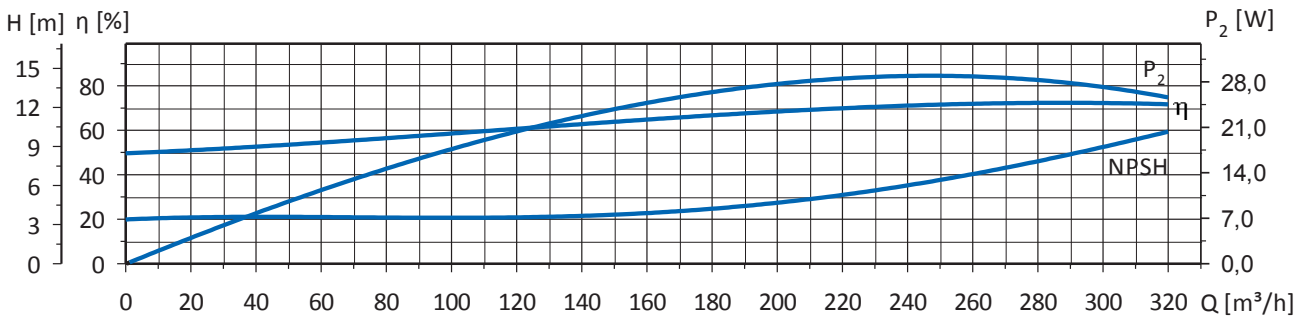
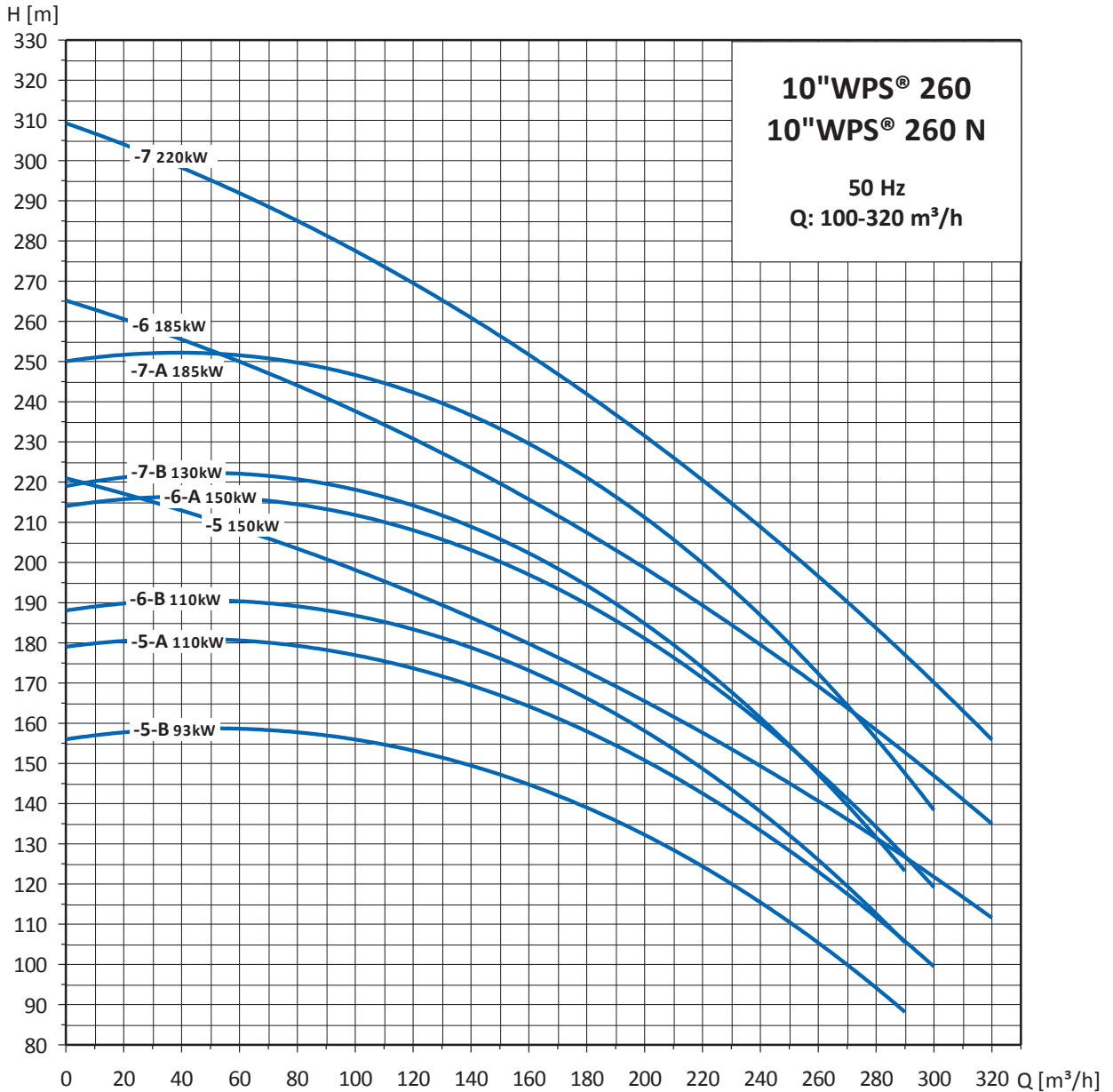

Technical Data

Selection Chart 10"WPS® 260 and 10"WPS® 260 N

Pump Type	Pump Power P ₂		Flow [m ³ /h]								Full load current 3x400V
	[kW]	[HP]	0	100	150	200	230	260	290	300	
10"WPS® 260-1-B	18,5	25	31	31	29	26	24	21	18		38
10"WPS® 260-1-A	22	30	35	35	33	30	28	25	21		44
10"WPS® 260-1	30	40	44	40	37	33	31	28	24	22	61
10"WPS® 260-2-B	37	50	62	62	58	53	48	43	35		73
10"WPS® 260-2-A	45	60	71	71	67	60	54	49	42		85
10"WPS® 260-2	55	75	88	79	73	66	62	56	50	43	103
10"WPS® 260-3-B	55	75	93	93	88	79	72	63	5		103
10"WPS® 260-3-A	67	90	108	107	100	91	82	75	63		120
10"WPS® 260-3	93	125	133	119	110	100	92	84	75	67	183
10"WPS® 260-4-B	75	100	125	124	117	106	96	84	69		145
10"WPS® 260-4-A	93	125	143	141	133	121	110	99	84		183
10"WPS® 260-4	110	150	177	158	146	133	123	112	102	89	223
10"WPS® 260-5-B	93	125	156	156	147	133	119	106	88		183
10"WPS® 260-5-A	110	150	179	177	167	151	137	124	106		223
10"WPS® 260-5	150	175	221	198	183	166	154	140	126	112	288
10"WPS® 260-6-B	110	150	188	187	176	158	143	127	105		223
10"WPS® 260-6-A	150	175	214	212	200	181	166	148	127		288
10"WPS® 260-6	185	230	265	238	219	199	185	168	153	135	325
10"WPS® 260-7-B	130	175	219	218	206	185	167	148	123		255
10"WPS® 260-7-A	185	230	250	247	233	211	193	174	146		325
10"WPS® 260-7	220	300	309	277	256	233	215	197	175	157	384

10"WPS®

Dimensions and Weights 10"WPS® 260 and 10"WPS® 260 N

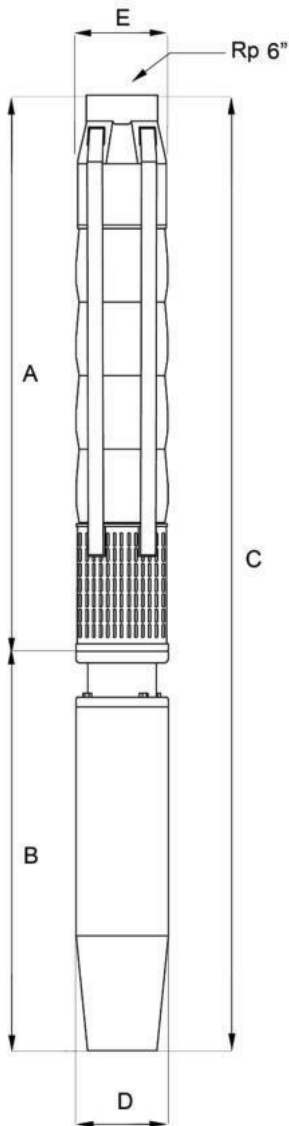

Pump Type	A [mm]	B [mm]	C [mm]	D [mm]	E [mm]	E* [mm]	Motor Type	Weight [kg]	
								Pump end	Electro-pump
10"WPS® 260-1-B	655	842	1497	139	250	255	6"	42	106
10"WPS® 260-1-A	655	907	1562	139	250	255	6"	42	112
10"WPS® 260-1	655	1037	1692	139	250	255	6"	42	127
10"WPS® 260-1	655	1140	1795	139	250	255	8"	42	182
10"WPS® 260-2-B	835	1274	2109	139	250	255	6"	58	160
10"WPS® 260-2-B	835	1140	1975	139	250	255	8"	58	218
10"WPS® 260-2-A	835	1629	2464	139	250	255	6"	58	205
10"WPS® 260-2-A	835	1274	2109	139	250	255	8"	58	214
10"WPS® 260-2	835	1340	2175	139	250	255	8"	58	237
10"WPS® 260-3-B	1015	1340	2355	194	250	255	8"	73	253
10"WPS® 260-3-A	1015	1470	2485	139	250	255	8"	73	271
10"WPS® 260-3	1015	1740	2755	194	250	255	8"	73	320
10"WPS® 260-3	1015	1419	2434	194	250	255	10"	73	353
10"WPS® 260-4-B	1195	1470	2665	139	250	255	8"	89	304
10"WPS® 260-4-A	1195	1740	2935	194	250	255	8"	89	336
10"WPS® 260-4-A	1195	1419	2614	194	250	255	10"	89	369
10"WPS® 260-4	1195	1976	3171	139	250	255	8"	89	467
10"WPS® 260-4	1195	1529	2724	139	250	255	10"	89	404
10"WPS® 260-5-B	1375	1740	3115	194	250	255	8"	105	352
10"WPS® 260-5-B	1375	1419	2794	194	250	255	10"	105	385
10"WPS® 260-5-A	1375	1976	3351	194	250	255	8"	105	483
10"WPS® 260-5-A	1375	1529	2904	194	250	255	10"	105	420
10"WPS® 260-5	1375	1976	3351	194	250	255	8"	105	599
10"WPS® 260-5	1375	1529	2904	194	250	255	10"	105	518
10"WPS® 260-6-B	1555	1976	3531	194	250	255	8"	121	499
10"WPS® 260-6-B	1555	1529	3084	194	250	255	10"	121	436
10"WPS® 260-6-A	1555	1976	3531	194	250	255	8"	121	615
10"WPS® 260-6-A	1555	1529	3084	194	250	255	10"	121	534
10"WPS® 260-6	1555	1919	3474	235	250	255	10"	121	570
10"WPS® 260-7-B	1735	2179	3914	194	250	255	8"	137	557
10"WPS® 260-7-B	1735	1659	3394	194	250	255	10"	137	499
10"WPS® 260-7-A	1735	1919	3654	235	250	255	10"	137	586
10"WPS® 260-7	1735	1893	3628	194	250	255	10"	137	800

10"WPS®

* With 2 cable guards

Performance Curves

Performance Curves 10"WPS® 300 and 10"WPS® 300 N

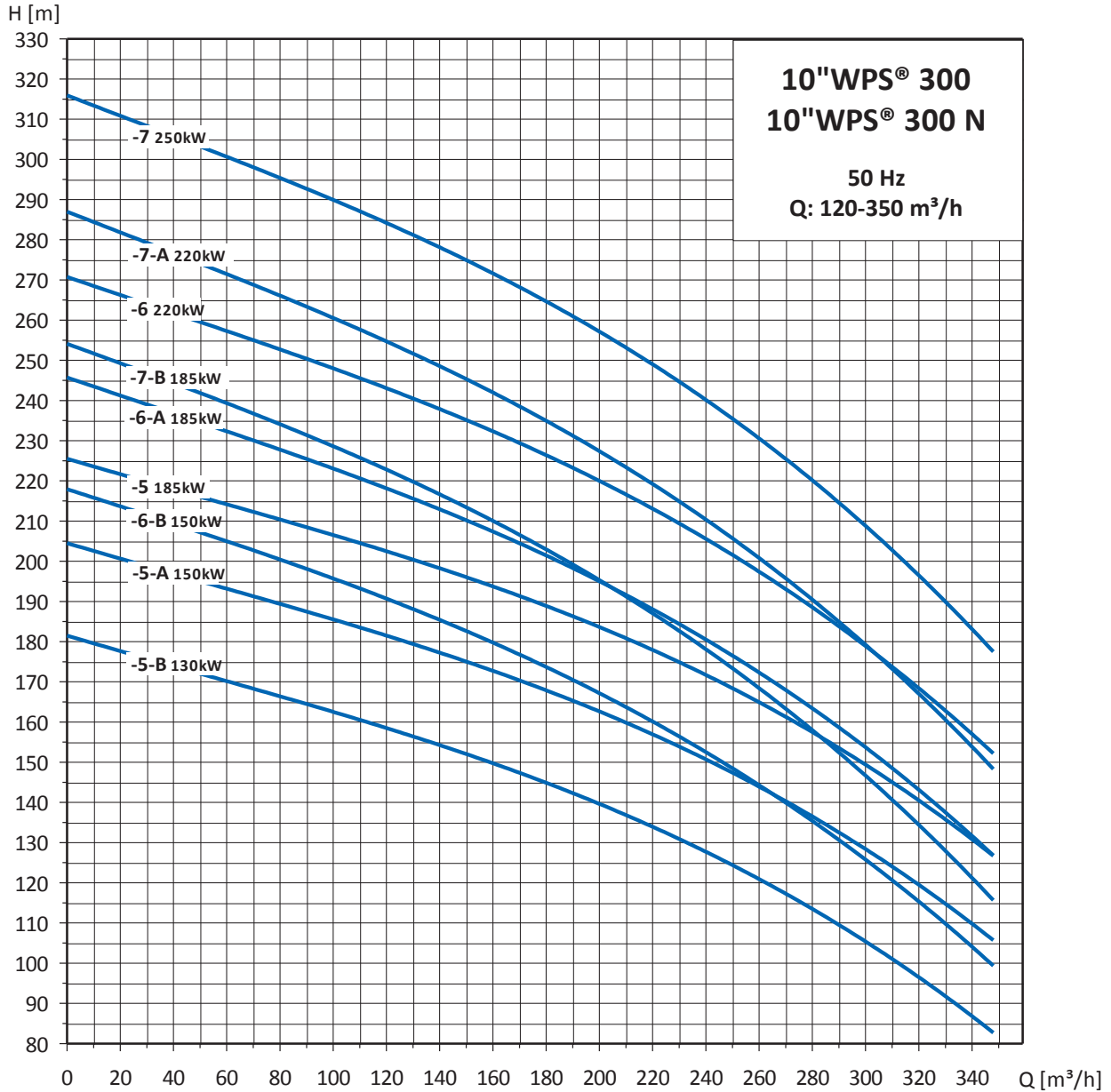

10"WPS®

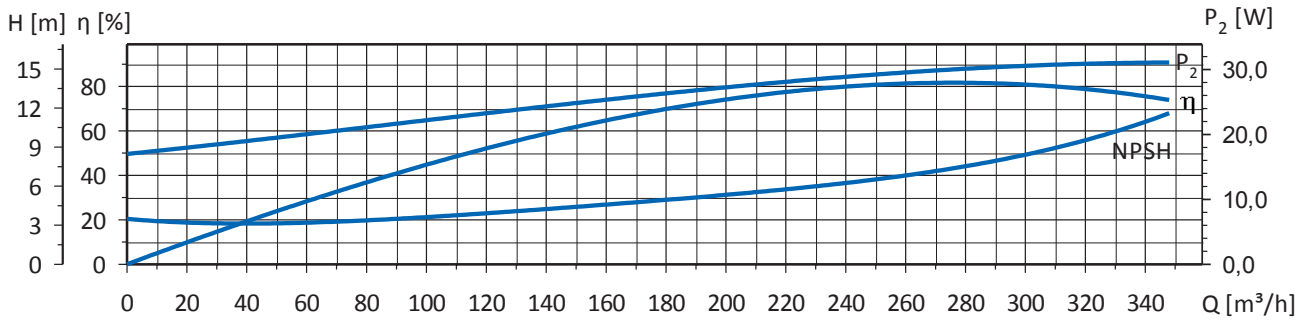

Performance Curves 10"WPS® 300 and 10"WPS® 300 N

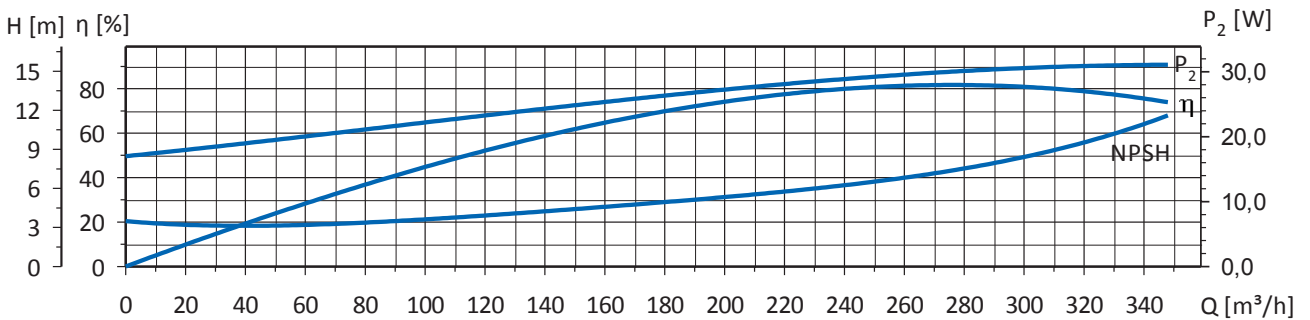
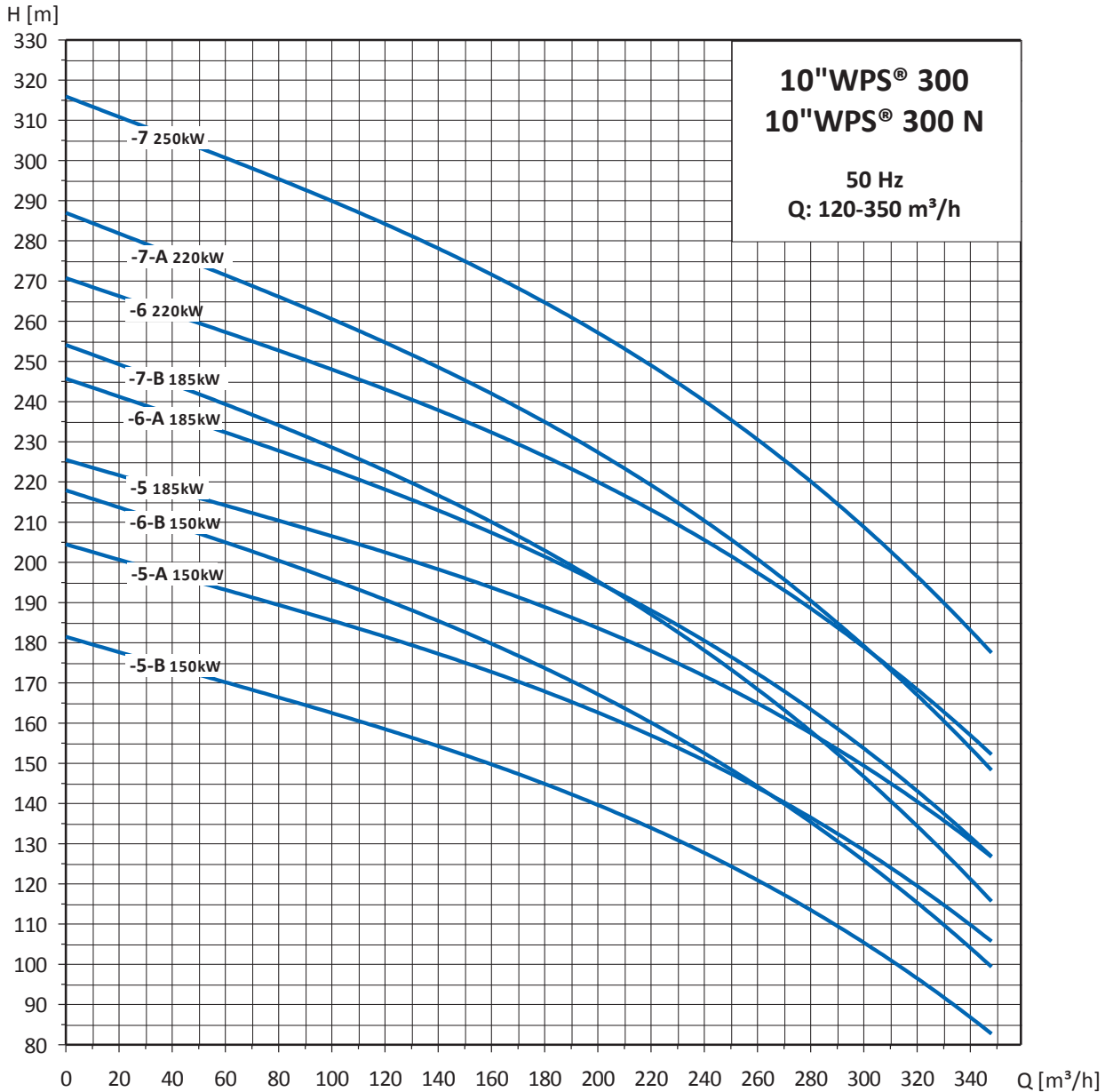

10"WPS®

Technical Data

Selection Chart 10"WPS® 300 and 10"WPS® 300 N

Pump Type	Pump Power P ₂		Flow [m ³ /h]								Full load current 3x400V
	[kW]	[HP]	0	180	210	240	270	300	330	348	
10"WPS® 300-1-B	26	30	36	30	28	24	23	20	18	17	53
10"WPS® 300-1-A	30	40	41	35	32	28	26	23	22	21	63
10"WPS® 300-1	45	60	45	37	36	34	32	30	28	24	94
10"WPS® 300-2-B	52	70	72	58	53	51	45	42	37	33	103
10"WPS® 300-2-A	55	75	82	68	63	60	53	52	47	43	110
10"WPS® 300-2	67	90	90	74	71	68	64	60	56	48	130
10"WPS® 300-3-B	75	100	109	87	81	76	68	62	57	47	148
10"WPS® 300-3-A	93	125	122	101	96	91	83	76	68	63	183
10"WPS® 300-3	110	150	135	111	107	101	96	89	83	74	222
10"WPS® 300-4-B	110	150	145	115	108	100	93	83	74	66	222
10"WPS® 300-4-A	130	175	163	134	127	120	112	102	92	87	235
10"WPS® 300-4	130	175	180	148	143	135	128	119	110	102	235
10"WPS® 300-5-B	130	175	181	144	136	126	115	103	92	83	235
10"WPS® 300-5-A	150	200	204	167	159	151	138	127	114	106	298
10"WPS® 300-5	185	230	225	185	178	169	160	149	138	127	340
10"WPS® 300-6-B	150	200	217	193	163	152	139	125	108	101	298
10"WPS® 300-6-A	185	230	245	202	191	180	166	152	137	128	340
10"WPS® 300-6	220	300	270	222	214	203	191	179	164	152	425
10"WPS® 300-7-B	185	230	253	203	190	176	161	146	128	117	340
10"WPS® 300-7-A	220	300	286	235	223	208	193	179	160	151	425
10"WPS® 300-7	250	340	315	261	250	237	223	209	192	176	425

10"WPS®

Dimensions and Weights 10"WPS® 300 and 10"WPS® 300 N

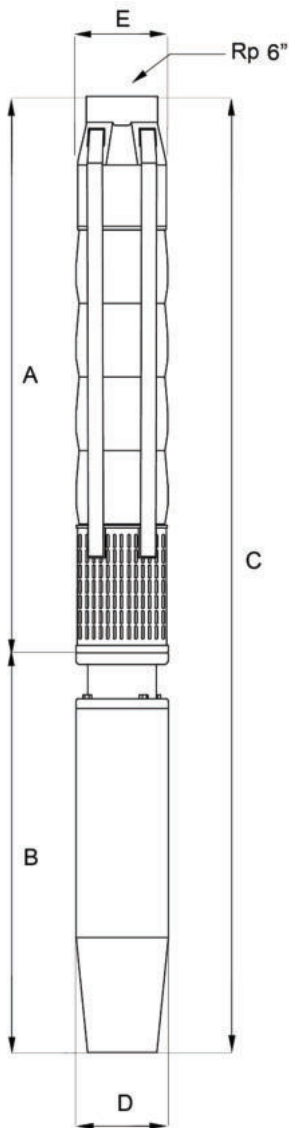

Pump Type	A [mm]	B [mm]	C [mm]	D [mm]	E [mm]	E* [mm]	Motor Type	Weight [kg]	
								Pump end	Electro-pump
10"WPS® 300-1-B	635	1094	1729	139	250	255	6"	41	226
10"WPS® 300-1-A	635	1274	1909	139	250	255	6"	41	126
10"WPS® 300-1-A	635	1140	1775	194	250	255	8"	41	181
10"WPS® 300-1	635	1629	2264	139	250	255	6"	41	188
10"WPS® 300-1	635	1274	1909	194	250	255	8"	41	197
10"WPS® 300-2-B	815	1340	2155	194	250	255	8"	56	235
10"WPS® 300-2-A	815	1340	2155	194	250	255	8"	56	235
10"WPS® 300-2	815	1470	2285	194	250	255	8"	56	254
10"WPS® 300-3-B	995	1560	2555	194	250	255	8"	72	287
10"WPS® 300-3-A	995	1740	2735	194	250	255	8"	72	319
10"WPS® 300-3-A	995	1419	2414	235	250	255	10"	72	352
10"WPS® 300-3	995	1976	2971	194	250	255	8"	72	450
10"WPS® 300-3	995	1529	2524	235	250	255	10"	72	387
10"WPS® 300-4-B	1175	1976	3151	194	250	255	8"	88	466
10"WPS® 300-4-B	1175	1529	2704	235	250	255	10"	88	403
10"WPS® 300-4-A	1175	2179	3354	194	250	255	8"	88	508
10"WPS® 300-4-A	1175	1659	2834	235	250	255	10"	88	450
10"WPS® 300-4	1175	2179	3354	194	250	255	8"	88	508
10"WPS® 300-4	1175	1659	2834	235	250	255	10"	88	450
10"WPS® 300-5-B	1355	2179	3534	194	250	255	8"	104	524
10"WPS® 300-5-B	1355	1659	3014	235	250	255	10"	104	466
10"WPS® 300-5-A	1355	2408	3763	194	250	255	8"	104	598
10"WPS® 300-5-A	1355	1769	3124	235	250	255	10"	104	517
10"WPS® 300-5	1355	1919	3274	194	250	255	8"	104	553
10"WPS® 300-6-B	1535	2408	3943	194	250	255	8"	119	613
10"WPS® 300-6-B	1535	1769	3304	235	250	255	10"	119	532
10"WPS® 300-6-A	1535	1919	3454	235	250	255	10"	119	568
10"WPS® 300-6	1535	1893	3428	235	250	255	10"	119	782
10"WPS® 300-7-B	1715	1919	3634	235	250	255	10"	135	584
10"WPS® 300-7-A	1715	1893	3608	235	250	255	10"	135	798
10"WPS® 300-7	1715	1893	3608	235	250	255	10"	135	798

10"WPS®

* With 2 cable guards

Technical Data

Material specification

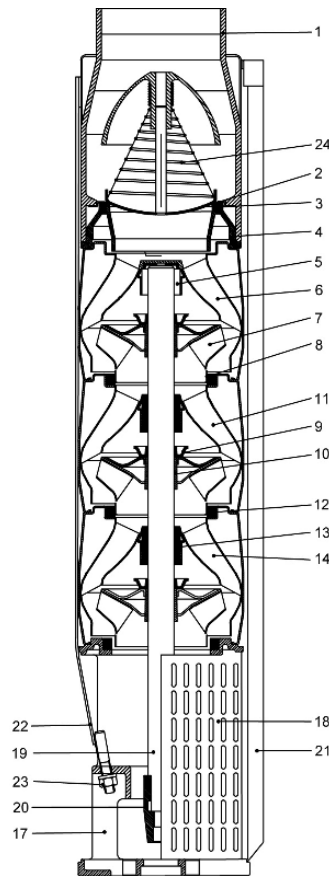

10"WPS® 120
 10"WPS® 155
 10"WPS® 220
 10"WPS® 260
 10"WPS® 300

10"WPS®

Pos.	Component	Material	10"WPS® Material Code	10"WPS® N Material Code	10"WPS® NE Material Code
1	Discharge Chamber	Stainless Steel	AISI 304 - 1.4301	AISI 316 - 1.4401	AISI 316 - 1.4401
2	Valve Cone	Stainless Steel	AISI 304 - 1.4301	AISI 316 - 1.4401	AISI 316 - 1.4401
3	Valve Seat	Stainless Steel/Rubber	AISI 316 -1.4401 / NBR	AISI 316 -1.4401 / NBR	PTFE
4	Valve seat Retainer	Stainless Steel	AISI 304 - 1.4301	AISI 316 - 1.4401	AISI 316 - 1.4401
5	Top Bearing	Rubber	NBR	NBR	PTFE
6	Top Diffuser	Stainless Steel	AISI 304 - 1.4301	AISI 316 - 1.4401	AISI 316 - 1.4401
7	Impeller	Stainless Steel	AISI 304 - 1.4301	AISI 316 - 1.4401	AISI 316 - 1.4401
8	Wear Ring Impeller	Stainless Steel	AISI 304 - 1.4301	AISI 316 - 1.4401	AISI 316 - 1.4401
9	Nut for Conical Bush	Stainless Steel	AISI 304 - 1.4301	AISI 316 - 1.4401	AISI 316 - 1.4401
10	Conical Bush	Stainless Steel	AISI 304 - 1.4301	AISI 316 - 1.4401	AISI 316 - 1.4401
11	Diffuser	Stainless Steel	AISI 304 - 1.4301	AISI 316 - 1.4401	AISI 316 - 1.4401
12	Neck Ring	Stainless Steel/Rubber	AISI 316 -1.4401 / NBR	AISI 316 -1.4401 / NBR	PTFE
13	Intermediate Bearing	Rubber	NBR	NBR	PTFE
14	Bottom Diffuser	Stainless Steel	AISI 304 - 1.4301	AISI 316 - 1.4401	AISI 316 - 1.4401
17	Suction Interconnector	Stainless Steel	AISI 304 - 1.4301	AISI 316 - 1.4401	AISI 316 - 1.4401
18	Strainer	Stainless Steel	AISI 304 - 1.4301	AISI 316 - 1.4401	AISI 316 - 1.4401
19	Shaft	Stainless Steel	AISI 431 - 1.4057	AISI 316 - 1.4401	AISI 316 - 1.4401
20	Coupling	Stainless Steel	AISI 304 - 1.4301	AISI 316 - 1.4401	AISI 316 - 1.4401
21	Cable Guard	Stainless Steel	AISI 304 - 1.4301	AISI 316 - 1.4401	AISI 316 - 1.4401
22	Strap	Stainless Steel	AISI 304 - 1.4301	AISI 316 - 1.4401	AISI 316 - 1.4401
23	Nut	Stainless Steel	AISI 316 - 1.4401	AISI 316 - 1.4401	AISI 316 - 1.4401
24	Spring	Stainless Steel	AISI 304 - 1.4301	AISI 316 - 1.4401	AISI 316 - 1.4401

Cooling Shrouds

The cooling shrouds are designed to ensure a sufficient flow velocity past the motor in order to provide sufficient cooling. For the following cases a cooling shroud is recommended:

- horizontal or vertical installation in a tank
- installation of the pump in the screen from the well
- installation in big sized well not ensuring enough cooling velocity. See table.

Minimum flow required for motor cooling in water up to 20°C.			
Casing or sleeve I.D. [mm (inches)]	6" motor, cooling flow 16cm/sec [m ³ /h]	8", cooling flow 25cm/sec [m ³ /h]	10", cooling flow 5cm/sec [m ³ /h]
253 (10")	20,4	20,0	12,4
305 (12")	31,8	40,5	53,4
355 (14")	48,6	63,8	100,0
406 (16")	66,2	91,2	154,9
457 (18")	86,1	122,3	217,1

To the shroud itself, a screen can be added. In case of horizontal installation a set of supports are available.

Fits to pump type	Description	Material	Motor Size	Reference
10"WPS® 120-1-A upto 1	Ø256 (275) x 800	1.4301 - AISI 304	6" up to 11 kW	79010
10"WPS® 155-1-A				
10"WPS® 155-1	Ø256 (275) x 1000	1.4301 - AISI 304	6" Rew. of 13 kW	79020
10"WPS® 155-1-A				
10"WPS® 120-2 upto 3-AA	Ø256 (275) x 1000	1.4301 - AISI 304	6" up to 22 kW	79030
10"WPS® 155-2-A				
10"WPS® 120-3-A	Ø256 (275) x 1250	1.4301 - AISI 304	6" Rew. of 26 kW	79040
10"WPS® 155-2				
10"WPS® 120-3	Ø256 (275) x 1250	1.4301 - AISI 304	6" up to 30 kW	79050
10"WPS® 155-3-AA				
10"WPS® 120-4-AA upto 4	Ø256 (275) x 1500	1.4301 - AISI 304	6" Rew. of 37 kW*	79060
10"WPS® 155-3-A upto 3				
10"WPS® 120-5-AA upto 5-A	Ø256 (275) x 1800	1.4301 - AISI 304	6" Enc. of 45 kW*	79070
10"WPS® 155-4-AA upto 4-A				
10"WPS® 120-3 upto 5-A	Ø285 (300) x 1250	1.4301 - AISI 304	8" up to 45 kW	79080
10"WPS® 155-3-AA upto 4-A				
10"WPS® 120-5 upto 7	Ø285 (300) x 1500	1.4301 - AISI 304	8" up to 67 kW	79090
10"WPS® 155-4 upto 6-A				
10"WPS® 120-8-AA upto 10	Ø285 (300) x 1800	1.4301 - AISI 304	8" up to 93 kW*	79100
10"WPS® 155-6 upto 8				
10"WPS® 120-9-AA upto 10	Ø330 (350) x 1500	1.4301 - AISI 304	10" up to 93 kW	79110
10"WPS® 155-7-A upto 8				
10"WPS® 120-11 upto 13	Ø330 (350) x 1700	1.4301 - AISI 304	10" up to 130 kW	79120
10"WPS® 155-9-AA upto 12				
10"WPS® 120-14 upto 17	Ø330 (350) x 2000	1.4301 - AISI 304	10" up to 185 kW*	79130
10"WPS® 155-13 upto 15				
10"WPS® 220-1-A upto 1	Ø330 (350) x 1000	1.4301 - AISI 304	6" up to 18,5 kW	79140
10"WPS® 220-2-AA				
10"WPS® 220-2-A	Ø330 (350) x 1500	1.4301 - AISI 304	6" Rew. of 37 kW	79160
10"WPS® 220-2				
10"WPS® 220-2-AA upto 2	Ø330 (350) x 1800	1.4301 - AISI 304	6" of 45 kW	79170
10"WPS® 220-2				
10"WPS® 220-2-AA upto 2	Ø330 (350) x 1250	1.4301 - AISI 304	8" up to 45 kW	79180
10"WPS® 220-3-AA upto 3-A				
10"WPS® 220-3 upto 4	Ø330 (350) x 1500	1.4301 - AISI 304	8" up to 55 kW	79190
10"WPS® 220-3-AA upto 3-A				
10"WPS® 220-3 upto 4	Ø330 (350) x 1700	1.4301 - AISI 304	8" up to 75 kW	79200
10"WPS® 220-3-AA upto 3-A				
10"WPS® 220-5-AA upto 5	Ø330 (350) x 2000	1.4301 - AISI 304	8" up to 93 kW	79210
10"WPS® 220-5-AA upto 5				
10"WPS® 220-5-AA upto 5	Ø380 (400) x 1500	1.4301 - AISI 304	10" up to 93 kW*	79220
10"WPS® 220-6-AA upto 7				
10"WPS® 220-6-AA upto 7	Ø380 (400) x 1800	1.4301 - AISI 304	10" up to 130 kW	79230
10"WPS® 220-8-AA upto 10				
10"WPS® 220-8-AA upto 10	Ø380 (400) x 2000	1.4301 - AISI 304	10" up to 185 kW*	79240
10"WPS® 220-9-AA upto 10				
10"WPS® 220-9-AA upto 10	Ø380 (400) x 2000	1.4301 - AISI 304	12" up to 185 kW	79250
10"WPS® 220-11				
10"WPS® 220-11	Ø380 (400) x 2250	1.4301 - AISI 304	12" up to 220 kW	79260

* not suitable for horizontal installation

Accessories



Screen Ø256 x 325	1.4301 - AISI 304	Screen for shroud Ø256 mm	78310
Screen Ø285 x 325	1.4301 - AISI 304	Screen for shroud Ø285 mm	79300
Screen Ø330 x 325	1.4301 - AISI 304	Screen for shroud Ø330 mm	79310
Screen Ø385 x 325	1.4301 - AISI 304	Screen for shroud Ø385 mm	79320

Set of 2 supports for shroud Ø256 mm	1.4301 - AISI 304	79400
Set of 3 supports for shroud Ø256 mm	1.4301 - AISI 304	79410
Set of 2 supports for shroud Ø285mm	1.4301 - AISI 304	79420
Set of 3 supports for shroud Ø285mm	1.4301 - AISI 304	79430
Set of 3 supports for shroud Ø330mm for 10"WPS 120-155	1.4301 - AISI 304	79440
Set of 2 supports for shroud Ø330mm for 10"WPS 220 - motor 6»	1.4301 - AISI 304	79450
Set of 3 supports for shroud Ø330mm for 10"WPS 220 - motor 6»	1.4301 - AISI 304	79460
Set of 2 supports for shroud Ø330mm for 10"WPS 220 - motor 8»	1.4301 - AISI 304	79470
Set of 3 supports for shroud Ø330mm for 10"WPS 220 - motor 8»	1.4301 - AISI 304	79480
Set of 3 supports for shroud Ø380mm for 10"WPS 220	1.4301 - AISI 304	79490

10"WPS®

Cooling schrouds in material 1.4401 - AISI 316 are available upon request

Well Pumps 4"WPM Encapsulated Motor

Technical specifications

- Ratings: 0,37kW up to 7,5 kW
- Encapsulated resin filled stator.
- Operation with frequency drive allowed
- 4" NEMA mounting design
- Maximum ambient temperature 35°C with 0,08 m/s cooling flow
- Voltage tolerance: -10% / +6% (50 Hz)
- Protection IP68 / insulation class F
- Frequency of starts: maximum 30 times per hour at regular intervals.
- Vertical and horizontal operation
- Maximum immersion depth 150m
- Frequency drive operation possible.
(Output filters required in function of cable lengths)

Product benefits

- factory filled with non-toxic water soluble fill solution
- Stainless steel splined shaft and motor shell
- All motors with factory installed leads (1,75/4m)
- Liquid lubricated radial bearings
- High-capacity Kingsbury type water lubricated thrust bearing for 100% maintenance free operation
- Universal field replaceable lead with stainless steel jam nut
- Pressure-equalizing diaphragm
- High efficiency electrical design for low operation costs
- All motors manufactured in ISO 9001 certified plants and 100% tested
- Drinking water approvals

Options

- special lead length up to 50 m

Operating data

Reference	P _N	Thrust	U _N	I _N	I _A	cos φ	n _N	Eff	Capacitor	L	M	∅	
	[kW]	[N]	[V]	[A]	[A]		[min ⁻¹]	[%]	[µF]	[mm]	[kg]	[mm ²]	
Single Phase	5003E104	0,37	1500	230	3,4	11,0	0,90	2850	54	16	250	6,8	4G1,5
	5005E104	0,55	1500	230	4,4	16,6	0,88	2840	62	20	265	8,1	4G1,5
	5007E104	0,75	1500	230	6,0	23,1	0,86	2880	63	30	295	10,6	4G1,5
	5011E104	1,10	3000	230	7,8	29,6	0,90	2880	68	40	340	11,2	4G1,5
	5015E104	1,50	3000	230	10,5	39,3	0,96	2850	65	50	375	14,0	4G1,5
	5022E104	2,20	3000	230	15,0	52,5	0,92	2860	72	70	430	16,4	4G1,5

Reference	P _N	Thrust	U _N	I _N	I _A	cos φ	n _N	Eff	L	M	∅	
	[kW]	[N]	[V]	[A]	[A]		[min ⁻¹]	[%]	[mm]	[kg]	[mm ²]	
Three Phase	5003E504	0,37	1500	400	1,3	5,3	0,72	2870	62	462	5,8	4G1,5
	5005E504	0,55	1500	400	1,7	7,2	0,71	2860	66	250	7,0	4G1,5
	5007E504	0,75	1500	400	2,2	9,2	0,73	2840	67	265	8,3	4G1,5
	5011E504	1,10	3000	400	3,0	14,2	0,74	2840	72	295	10,9	4G1,5
	5015E504	1,50	3000	400	4,0	18,5	0,75	2830	72	340	11,4	4G1,5
	5022E504	2,20	3000	400	5,6	26,5	0,77	2830	74	375	14,2	4G1,5
	5030E504	3,00	6500	400	7,5	34,3	0,77	2830	76	480	18,3	4G1,5
	5040E504	4,00	6500	400	10,6	44,0	0,79	2830	69	555	23,4	4G1,5
	5055E504	5,50	6500	400	13,6	62,0	0,82	2830	72	675	29,4	4G1,5
	5075E504	7,50	6500	400	18,3	90,0	0,79	2840	75	765	33,8	4G1,5



Motors

Well Pumps 6"WPM Encapsulated Motor



Technical specifications

- Ratings: 4kW up to 45kW
- Encapsulated resin filled stator.
- Operation with frequency drive allowed
- 6" NEMA mounting design
- Maximum ambient temperature 35°C with 0,16 m/s cooling flow
- Voltage tolerance +/-10%
- Protection IP68 / insulation class B
- Frequency of starts: maximum 20 times per hour at regular intervals.
- Vertical and horizontal operation
- Maximum immersion 350m
- Frequency drive operation possible. (Output filters required in function of cable length)

Product benefits

- Factory filled with non-toxic water soluble fill solution
- Stainless steel splined shaft and motor shell
- All motors with factory installed leads (4m)
- Liquid lubricated radial bearings
- SiC/SiC-mechanical seal with sand slinger
- High-capacity Kingsbury type water lubricated thrust bearing for 100% maintenance free operation
- Field replaceable lead with stainless steel jam nut
- Pressure-equalizing diaphragm
- High efficiency electrical design for low operation costs
- All motors manufactured in ISO 9001 certified plants and 100% tested
- Drinking water approvals

Options

- Other voltages
- Star-Delta start
- Motor complete in AISI 316
- PT100 temperature sensor
- Special lead lengths up to 50m



Operating data

Reference	P _N	Thrust	U _N	I _N	I _A	cos φ	η _N	Eff	L	M	∅
	[kW]	[N]	[V]	[A]	[A]		[min ⁻¹]	[%]	[mm]	[kg]	[mm ²]
5040G506	4,0	15500	400	9,3	47	0,83	2790	76	572	44,5	4G6
5055G506	5,5	15500	400	12,7	64	0,83	2805	77	614	47,5	4G6
5075G506	7,5	15500	400	16,8	84	0,83	2820	79	669	51,0	4G6
5093G506	9,3	15500	400	20,1	101	0,86	2810	79	669	51,0	4G6
5110G506	11,0	15500	400	24,4	122	0,85	2810	79	735	56,0	4G6
5150G506	15,0	15500	400	32,5	163	0,85	2800	79	820	64,5	4G6
5185G506	18,5	15500	400	38,9	195	0,87	2805	80	892	71,0	4G6
5220G506	22,0	15500	400	44,3	222	0,89	2845	81	972	83,5	4G6
5300G506	30,0	27500	400	60,5	303	0,90	2830	81	1062	91,5	4G6
5370G506	37,0	27500	400	74,8	374	0,89	2860	83	1132	99,5	4G6
5450G506	45,0	27500	400	94,3	472	0,86	2830	83	1132	99,5	4G8

Well Pumps 8" and 10"WPM Rewindable Motors

Technical specifications

- Water filled rewindable stator, generously dimensioned
- Standard with PE2/PA winding, operation with frequency drive allowed (output filters required in function of cable lengths)
- Factory filled with non-toxic water soluble fill solution
- 8" NEMA mounting design - 10" mounting design Franklin
- Ratings 8"WPM: 22kW up to 110kW
- Ratings 10"WPM: 59kW up to 190kW
- Maximum ambient temperature 60°C with 0,15 m/s cooling flow
- Voltage tolerance +/-10%
- Protection IP68 / insulation class A
- Frequency of starts: maximum 10 times per hour at regular intervals.
- Vertical and horizontal operation (8" 92-110kW, 10" 150-190kW model only vertical)
- Maximum immersion 500m

Product benefits

- The rotors are balanced and ground along the whole axis
- Industry-leading efficiency with low operating costs
- Stainless steel shaft and motor shell
- Liquid lubricated radial bearings
- Sand protection: the sand-guard and silicon-carbide SIC-SIC mechanical seal protect against sand during operation
- High-capacity Kingsbury type water lubricated thrust bearing for 100% maintenance free operation
- Disassembly and maintenance is exceptionally simple
- Pressure-equalizing diaphragm
- High efficiency electrical design for low operation costs
- All motors manufactured in ISO 9001 certified plants and 100% tested
- Drinking water approvals

Options

- Special voltages and frequencies
- Star-Delta start
- Motor complete in AISI 316, AISI 904L, Duplex and Super Duplex
- PT100 temperature sensor
- Special lead lengths up to 50m
- 4-pole motors



Motors

Operating data

Reference	P _N	Thrust	U _N	I _N	I _A	cos φ	n _N	Eff	L	M	∅	
	[kW]	[N]	[V]	[A]	[A]		[min ⁻¹]	[%]	[mm]	[kg]	[mm ³]	
8" motor	5220C508	22	50000	400	47	188	0,83	2901	81,5	979	128	1x10
	5260C508	26	50000	400	55	220	0,83	2890	83,8	979	131	1x10
	5300C508	30	50000	400	61	244	0,85	2886	83,9	1049	137	1x10
	5370C508	37	50000	400	76	304	0,84	2890	84,8	1119	157	1x16
	5450C508	45	50000	400	91	364	0,84	2900	86,0	1229	169	1x16
	5510C508	51	60000	400	103	412	0,85	2879	84,9	1229	170	1x16
	5550C508	55	60000	400	107	428	0,85	2890	86,7	1349	194	1x16
	5600C508	60	60000	400	116	464	0,83	2898	87,5	1349	194	1x16
	5620C508	62	60000	400	118	480	0,84	2892	88,6	1349	194	1x16
	5660C508	66	70000	400	129	516	0,84	2883	87,1	1419	210	1x25
	5750C508	75	70000	400	146	584	0,85	2890	86,9	1609	241	1x25
	5920C508	92	70000	400	181	724	0,83	2900	88,5	1679	251	1x25
5011C508	110	70000	400	226	904	0,81	2899	86,3	1789	267	1x25	

Reference	P _N	Thrust	U _N	I _N	I _A	cos φ	n _N	Eff	L	M	∅	
	[kW]	[N]	[V]	[A]	[A]		[min ⁻¹]	[%]	[mm]	[kg]	[mm ³]	
10" motor	5600C501	60	80000	400	122	549	0,83	2889	84,0	1319	298	1x25
	5750C501	75	80000	400	154	693	0,83	2900	84,8	1439	334	1x25
	5920C501	92	80000	400	184	828	0,84	2891	85,7	1569	367	1x25
	5011C501	110	80000	400	217	977	0,84	2907	87,1	1709	382	1x35
	5013C501	132	80000	400	262	1179	0,85	2892	87,0	1809	440	1x50
	5015C502	150	80000	400	294	1323	0,83	2907	88,1	1929	484	1x70
	5017C501	170	80000	400	334	1503	0,83	2900	87,5	2029	508	1x70
	5019C501	190	80000	400	374	1683	0,83	2904	88,3	2129	544	1x95

Franklin Electric 4" Encapsulated Motor



Technical specifications

- Ratings: 0,25kW up to 9,3 kW
- StatorShield™ - Franklin encapsulation system
- Operation with frequency drive allowed
- 4" NEMA mounting design
- Maximum ambient temperature 30°C with 0,08 m/s cooling flow
- Voltage tolerance: -10% / +6% (50 Hz)
- Protection IP68 / insulation class B
- Frequency of starts: maximum 20 times per hour with 3 minutes rest period
- Vertical and horizontal operation
- Frequency drive operation possible. (Output filters required in function of cable lengths)

Product benefits

- Factory filled with non-toxic water soluble fill solution
- Stainless steel splined shaft and stator shell
- All motors with factory installed leads (1,5 / 2,5m)
- Liquid lubricated radial bearings
- High-capacity Kingsbury type water lubricated thrust bearing for 100% maintenance free operation
- Field replaceable lead using Franklin's exclusive Water Bloc technology with longer ss jam nut
- Pressure-equalizing diaphragm
- High efficiency electrical design for low operation costs
- All motors manufactured in ISO 9001 certified plants and 100% tested
- Drinking water approvals



Options

- Special lead length up to 50 m
- Motor complete in AISI 316

Operating data

Reference	P _N	Thrust	U _N	I _N	I _A	cos φ	n _N	Eff	Capacitor	L	T	∅	
	[kW]	[N]	[V]	[A]	[A]		[min ⁻¹]	[%]	[μF]	[mm]	[kg]	[mm ³]	
Single Phase	5003M104	0,37	4000	230	3,3	12,6	0,97	2860	54	16	251	7,2	4G1,5
	5005M104	0,55	4000	230	4,3	17,7	0,94	2850	63	20	276	8,4	4G1,5
	5007M104	0,75	4000	230	5,7	22,7	0,98	2845	59	35	297	9,3	4G1,5
	5011M104	1,10	4000	230	8,4	33,9	0,92	2845	63	40	321	10,5	4G1,5
	5015M104	1,50	4000	230	10,7	41,7	0,95	2830	66	50	353	11,9	4G1,5
	5022M104	2,20	4000	230	14,7	61,8	0,97	2840	68	70	451	16,7	4G1,5

Reference	P _N	Thrust	U _N	I _N	I _A	cos φ	n _N	Eff	L	T	∅	
	[kW]	[N]	[V]	[A]	[A]		[min ⁻¹]	[%]	[mm]	[kg]	[mm ³]	
Three Phase	5003T504	0,37	3000	400	1,1	5,4	0,74	2870	66	237	6,3	4G1,5
	5005T504	0,55	3000	400	1,6	7,4	0,74	2870	68	251	7,2	4G1,5
	5007T504	0,75	3000	400	2,0	10,6	0,77	2865	70	271	8,0	4G1,5
	5011T504	1,10	3000	400	2,8	16,0	0,78	2850	74	397	9,3	4G1,5
	5015T504	1,50	3000	400	3,9	20,7	0,78	2855	73	321	10,3	4G1,5
	5022T504	2,20	3000	400	5,5	29,8	0,77	2845	75	353	11,8	4G1,5
	5030T504	3,00	4000	400	7,5	42,0	0,77	2845	76	408	14,3	4G1,5
	5037H504	3,70	4000	400	9,0	52,3	0,78	2840	78	520	19,1	4G1,5
	5040H504	4,00	6500	400	9,9	57,0	0,77	2840	78	643	20,0	4G1,5
	5055H504	5,50	6500	400	12,6	77,5	0,81	2865	79	652	26,6	4G1,5
	5075H504	7,50	6500	400	17,1	99,3	0,81	2855	79	730	30,6	4G1,5
	5093H505	9,30	6500	400	21,4	113,0	0,81	2850	79	855	37,9	4G1,5

Motors

Franklin Electric 6" Encapsulated Motor



Technical specifications

- Ratings: 4kW up to 45kW
- Encapsulated resin filled stator.
- Operation with frequency drive allowed
- 6" NEMA mounting design
- Maximum ambient temperature 30°C with 0,16 m/s cooling flow
- Voltage tolerance -10% / +6%
- Protection IP68 / insulation class B
- Frequency of starts: maximum 20 times per hour at regular intervals.
- Vertical and horizontal operation
- Frequency drive operation possible.
(Output filters required in function of cable lengths)

Product benefits

- Factory filled with non-toxic water soluble fill solution
- Stainless steel splined shaft and motor shell
- All motors with factory installed leads (4m)
- Liquid lubricated radial bearings
- Sand Fighter Motor with SiC-mechanical seal with sand slinger
- High-capacity Kingsbury type water lubricated thrust bearing for 100% maintenance free operation
- Field replaceable lead with brass jam nut
- Pressure-equalizing diaphragm
- High efficiency electrical design for low operation costs
- All motors manufactured in ISO 9001 certified plants and 100% tested
- Drinking water approvals

Options

- Other voltages
- Star-Delta start
- Motor complete in AISI 304 and AISI 316
- PT100 temperature sensor
- Special lead lengths up to 50m
- Built-in PTC temperature sensor
- Built-in SubMonitor Transmitter (standard for 37 and 45kW)



Operating data

Reference	P _N	Thrust	U _N	I _N	I _A	cos φ	η _N	Eff	L	M	∅
	[kW]	[N]	[V]	[A]	[A]		[min ⁻¹]	[%]	[mm]	[kg]	[mm]
5040D506	4,00	15 500	400	9,3	43	0,82	2860	78	581	41	4G4
5055D506	5,50	15 500	400	12,5	64	0,82	2870	79	614	45	4G4
5075D506	7,50	15 500	400	16,0	83	0,86	2860	79	646	49	4G4
5093D506	9,30	15 500	400	20,7	112	0,80	2870	81	679	50	4G4
5110D506	11,00	15 500	400	23,3	129	0,85	2860	81	711	55	4G4
5150D506	15,00	15 500	400	31,3	169	0,85	2860	81	776	61	4G4
5185D506	18,50	15 500	400	38,5	231	0,85	2860	82	842	67	4G4
5220D506	22,00	15 500	400	45,3	268	0,86	2860	83	907	73	4G4
5300D506	30,00	27 500	400	63,5	393	0,84	2860	83	1037	88	4G8,4
5370D506	37,00	45 000	400	77,9	411	0,85	2870	81	1477	140	4G8,4
5450D506	45,00	45 000	400	93,9	509	0,84	2870	82	1629	156	4G8,4

Franklin Electric Rewindable Motor

Technical specifications

- Ratings: 6" motor 4-37kW, 8" motor 30-93kW, 10" motor 85-185kW, 12" motor 185-400kW
- Water filled rewindable stator
- PVC winding insulation. (Frequency drive operation only with PE2/PA option)
- 6" and 8" NEMA mounting design, 10" and 12" double flange mounting design
- Maximum ambient temperature:
 - 6", 8" and 12" motor, 30°C with 0,5m/s cooling flow
 - 10" motor, 25°C with 0,5m/S cooling flow
- Voltage tolerance -10% / +6%
- Protection IP68 / insulation class B
- Frequency of starts:
 - 6" and 8" motor, maximum 20 starts/hour at regular intervals.
 - 10" motor, max 10 starts/hour at regular intervals
 - 12" motor, max. 5 starts/hour at regular intervals
- Vertical and horizontal operation (6"-37kW, 8"-93kW, 10"-185kW model only vertical)

Product benefits

- Factory filled with non-toxic water soluble fill solution
- Stainless steel splined shaft and motor shell
- All motors with factory installed leads (6" medels 4m, other motors 6m)
- Liquid lubricated radial bearings
- Sand Fighter Motor with SiC-mechanical seal with sand slinger
- High-capacity Kingsbury type water lubricated thrust bearing for 100% maintenance free operation
- Pressure-equalizing diaphragm
- High efficiency electrical design for low operation costs
- All motors manufactured in ISO 9001 certified plants and 100% tested
- Drinking water approvals

Options

- Other voltages
- Star-Delta start
- PE2/PA winding insulation for frequency drive operation, 6"-8" max. 50°C, 10" max. 45°C
- Motor complete in AISI 316 and AISI 904L available (12" only AISI 316)
- PT100 temperature sensor
- Special lead lengths up to 50m



Motors

Operating data

Reference	P _N	Thrust	U _N	I _N	I _A	cos φ	η _N	Eff	L	M	∅	
	[kW]	[N]	[V]	[A]	[A]		[min ⁻¹]	[%]	[mm]	[kg]	[mm ²]	
6" motor	5040L506	4,0	15 500	400	10,6	51	0,73	2930	76	679	43	4G2,5
	5055L506	5,5	15 500	400	13,3	51	0,81	2890	76	679	43	4G2,5
	5075L506	7,5	15 500	400	17,7	63	0,82	2880	77	699	45	4G2,5
	5093L506	9,3	15 500	400	21,4	78	0,82	2870	78	729	49	4G2,5
	5110L506	11,0	15 500	400	25,2	98	0,83	2880	79	759	53	4G2,5
	5130L506	13,0	15 500	400	29,6	130	0,81	2900	80	809	57	4G2,5
	5150L506	15,0	15 500	400	33,1	148	0,83	2890	81	854	61	4G4
	5185L506	18,5	15 500	400	42,0	189	0,80	2880	81	899	66	4G4
	5220L506	22,0	15 500	400	49,0	240	0,80	2900	82	989	77	4G4
	5260L506	26,0	15 500	400	56,7	296	0,83	2900	83	1094	88	4G6
	5300L506	30,0	27 500	400	66,4	347	0,80	2910	83	1194	98	4G6
	5370L506	37,0	27 500	400	81,9	433	0,80	2900	83	1274	105	4G6

Reference	P _N	Thrust	U _N	I _N	I _A	cos φ	η _N	Eff	L	M	∅	
	[kW]	[N]	[V]	[A]	[A]		[min ⁻¹]	[%]	[mm]	[kg]	[mm ²]	
8" motor	5300L508	30	45 500	400	60	318	0,89	2900	84	1140	140	4G10
	5370L508	37	45 500	400	76	400	0,86	2900	85	1140	140	4G10
	5450L508	45	45 500	400	90	520	0,86	2910	86	1230	156	4G10
	5520L508	52	45 500	400	103	608	0,87	2910	86	1340	179	4G16
	5550L508	55	45 500	400	110	660	0,86	2920	86	1340	179	4G16
	5600L508	60	45 500	400	116	725	0,88	2910	87	1470	198	4G16
	5670L508	67	45 500	400	133	797	0,86	2910	87	1470	198	4G16
	5750L508	75	45 500	400	148	942	0,87	2910	87	1560	215	4G16
	5830L508	83	45 500	400	160	1077	0,88	2920	88	1740	247	4G16
	5930L508	93	45 500	400	183	1276	0,86	2920	88	1740	247	3x25

Reference	P _N	Thrust	U _N	I _N	I _A	cos φ	η _N	Eff	L	M	∅	
	[kW]	[N]	[V]	[A]	[A]		[min ⁻¹]	[%]	[mm]	[kg]	[mm ²]	
10" motor	5850L501	85,00	60 000	400	174	828	0,85	2900	85	1419	280	4G25
	5011L501	110,00	60 000	400	232	1158	0,82	2920	86	1529	315	4G35
	5013L501	130,00	60 000	400	256	1344	0,86	2920	88	1659	362	4G35
	5015Q501	150,00	60 000	400	298	1590	0,85	2920	87	1769	413	3x25*
	5018Q501	185,00	60 000	400	384	2148	0,81	2920	88	1919	449	3x35*

Reference	P _N	Thrust	U _N	I _N	I _A	cos φ	η _N	Eff	L	M	∅	
	[kW]	[N]	[V]	[A]	[A]		[min ⁻¹]	[%]	[mm]	[kg]	[mm ²]	
12" motor	5018L502	185	60 000	400	351	1860	0,86	2945	87	1893	663	1x70
	5022L502	220	60 000	400	430	2322	0,87	2935	88	1893	663	1x70
	5025L502	250	60 000	400	481	2501	0,85	2935	88	1893	663	1x70
	5030L502	300	60 000	400	551	3086	0,88	2945	88	2043	726	1x70
	5035Q502	350	60 000	400	676	3515	0,88	2930	87	2143	769	1x35*
	5040Q502	400	60 000	400	750	3600	0,87	2930	90	2193	794	1x35*

* star-delta only

Cable Sizing

To select the cross-section of power cables for submersible pumps, consult the tables shown below. In these tables, the maximum lengths of drop cable for each cross-section are shown for each motor.

Cable dimensions at 1x230V, 50Hz

Voltage drop: 2%

Motor	Power		In [A]	Cos φ	Dimensions [mm ²]				
	KW	HP			1,5	2,5	4	6	10
4"	0,37	0,5	3,2	0,91	103	171	273	408	675
	0,55	0,75	4,1	0,94	78	129	206	309	512
	0,75	1	5,5	0,98	56	93	148	222	368
	1,1	1,5	8,1	0,92	40	67	107	159	264
	1,5	2	10,2	0,95	31	51	82	123	204
	2,2	3	14,1	0,97	-	36	58	87	145

Maximum cable length in meter from motor starter to pump.

Cable dimensions at 3x230V, 50Hz

Voltage drop: 3%

Motor	Power		In [A]	cos φ	Dimensions [mm ²]															
	[kW]	[HP]			1,5	2,5	4	6	10	16	25	35	50	70	95	120	150	180	240	
4"	0,37	0,5	1,9	0,74	169	282														
4"	0,55	0,75	2,8	0,76	112	186	297													
4"	0,75	1,1	3,7	0,75	86	143	227	339												
4"	1,1	1,5	5,2	0,76	60	100	160	238	393											
4"	1,5	2,2	6,9	0,76	45	76	120	180	296											
4"	2,2	3	10,2	0,75	31	52	83	123	203	320										
4"	3	4	13,5	0,75	24	39	62	93	153	241	369									
4"	3,7	5	15,8	0,79	19	32	51	76	125	197	301	412								
4"	4	5,5	17,3	0,78	18	29	47	70	115	182	278	380	525							
4"	5,5	7,5	23,7	0,79		21	34	50	83	131	201	275	380	510						
6"	4	5,5	16,1	0,82		30	48	72	118	187	287	393	545	734						
6"	5,5	7,5	21,7	0,82		22	36	53	88	139	213	292	404	545	706					
6"	7,5	10	27,7	0,86		17	27	40	66	104	160	220	306	415	541	658				
6"	9,3	12,5	36	0,8			22	33	54	85	131	179	248	333	431	519	615			
6"	11	15	40,4	0,85				28	46	72	111	152	212	286	373	453	540	620		
6"	15	20	54,2	0,85					34	54	83	114	158	214	278	337	403	462	568	
6"	18,5	25	66,7	0,85					28	44	67	92	128	173	226	274	327	376	461	
6"	22	30	78,5	0,86						37	56	78	108	146	191	232	277	319	393	
6"	30	40	107	0,84							42	58	81	109	142	172	204	234	287	
Max. current for the cable [A]					23	30	41	53	74	99	131	162	202	250	301	352	404	461	547	

Maximum cable length in meters from motor starter to pump.

In case of Star - Delta starting, the cable length can be increase times 1,7 as indicated in this table

Cable dimensions at 3x400V, 50Hz

Voltage drop: 3%

Motor	Power		In [A]	cos φ	Dimensions [mm ²]																													
	[kW]	[HP]			1,5	2,5	4	6	10	16	25	35	50	70	95	120	150	180	240	300														
4"	0,37	0,5	1,1	0,74	509	846																												
4"	0,55	0,75	1,6	0,74	350	582	927																											
4"	0,75	1,1	2,0	0,77	269	448	713	1064																										
4"	1,1	1,5	2,8	0,78	190	316	503	751	1239																									
4"	1,5	2,2	3,9	0,78	136	227	361	539	890																									
4"	2,2	3	5,5	0,77	98	163	259	387	639	1007																								
4"	3	4	7,5	0,77	72	119	190	284	468	738	1128																							
4"	3,7	5	9,0	0,78	59	98	157	234	386	608	930	1272																						
4"	4	5,5	9,9	0,77	54	90	144	215	355	559	855	1168																						
4"	5,5	7,5	12,6	0,81	41	68	108	161	266	420	643	882	1221																					
4"	7,5	10	17,1	0,81	30	50	79	119	196	309	474	650	900	1211																				
6"	4	5,5	9,3	0,82	54	90	144	215	356	563	863	1183																						
6"	5,5	7,5	12,5	0,82	40	67	107	160	265	419	642	880	1221																					
6"	7,5	10	16	0,86	30	50	80	120	198	313	482	663	923																					
6"	9,3	12,5	20,7	0,8	25	42	66	99	164	258	396	542	750	1008																				
6"	11	15	23,3	0,85		35	56	83	137	217	334	459	639	864	1124																			
6"	13	17,5	29,6	0,8		29	46	69	114	181	277	379	524	705	911	1098																		
6"	15	20	31,3	0,85			41	62	102	162	249	342	475	643	837	1016																		
6"	18,5	25	38,5	0,85			34	50	83	132	202	278	387	523	680	826	986																	
6"	22	30	45,3	0,86				42	70	111	170	234	326	441	575	699	836	962	1183	1374														
6"	26	35	56,7	0,83					58	91	140	192	267	360	467	565	673	770	941	1086														
6"	30	40	63,5	0,84					51	81	124	170	236	319	415	503	599	687	841	973														
6"	37	50	81,9	0,83						63	97	133	185	249	323	391	466	533	652	752														
6"	45	60	95,2	0,84						54	83	113	158	213	277	335	400	458	561	649														
8"	30	40	60	0,89					51	81	125	172	241	327	429	523	629	726	901	1054														
8"	37	50	76	0,86						66	101	140	194	263	343	417	498	573	705	819														
8"	45	60	90	0,86						56	86	118	164	222	290	352	421	484	596	691														
8"	52	70	103	0,87							74	102	142	193	252	307	367	423	522	607														
8"	55	75	110	0,86								70	96	134	182	237	288	344	396	487	566													
8"	60	80	116	0,88								65	90	125	170	223	271	325	375	465	542													
8"	67	85	133	0,86									80	111	150	196	238	285	327	403	468													
8"	75	100	148	0,87										71	99	134	175	213	255	294	363	422												
8"	83	110	160	0,88											65	91	123	161	197	236	272	337	393											
8"	93	125	183	0,86												81	109	142	173	207	238	293	340											
8"	110	150	222	0,84													91	119	144	171	197	241	278											
8"	130	175	252	0,87														103	125	150	173	213	248											
8"	150	200	284	0,88															91	111	133	153	190	221										
10"	75	100	145	0,85																72	103	139	181	219	262	301	369	427						
10"	85	110	174	0,81																	88	119	154	186	221	252	306	352						
10"	90	125	175	0,85																		85	115	150	182	217	249	306	354					
10"	110	150	215	0,86																			93	121	147	176	203	249	289					
10"	130	175	250	0,86																				80	104	127	152	174	214	249				
10"	150	200	290	0,86																					90	109	131	150	185	215				
10"	170	230	325	0,86																							97	117	134	165	191			
10"	190	260	365	0,86																									104	119	147	170		
10"	220	300	425	0,86																										102	126	146		
Max. Current-Carrying capacity [A]					23	30	41	53	74	99	131	162	202	250	301	352	404	461	547	633														

Maximum current-carrying capacity (A) for one cable, installed on surface (rubber or XLPE insulation)
 Maximum cable length in meters from motor starter to pump.
 In case of Star - Delta starting, the cable length can be increase times 1,7 as indicated in this table.

Terms and conditions

ACCEPTANCE OF THE PRESENT GENERAL TERMS OF SALE: No order can be made without the acceptance of the present terms. All orders are exclusively governed by these general terms of sale, excluding any other condition of purchase. The present general conditions are attached to the confirmation of orders and are deemed to be accepted if no explicit objections are raised within a three day period. The failure for the buyer to take note of the general conditions of WELL PUMPS in his/her mother tongue cannot alter their enforceability towards him/her.

OFFERS AND COMMANDS: Offer's validity from WELL PUMPS expires upon a two month period. Any command not preceded by a written offer from WELL PUMPS and unconditionally accepted, does not bind the latter unless it was accepted in writing. WELL PUMPS' agents and representatives do not have the power of representation.

PRICES: All prices are quoted in euros, VAT excluded. Any increase in VAT as well as any new tax imposed between the time of the order and the delivery shall be borne by the buyer. Prices cover only delivery from WELL PUMPS headquarters located Avenue de Charleroi Lambusart 18 BE-6220 Fleurus. Shipping charges will be added to the price of goods should the buyer requests WELL PUMPS to provide carriage of goods. Prices apply only to the supply of goods to the exclusion of any other work and services and in particular of the installation and assembly of material whose cost may be added to the price of the goods.

PAYMENT: Unless expressly agreed otherwise, all invoices from WELL PUMPS are payable to head office within 30 days of date of issue. All sums left unpaid by the due date, shall by rights and without formal notice, be subjected to a legal interest rate provided by the Belgian Act of August 2, 2002, transposing the European directive 2000/35/CE on combating late payment in commercial transactions. In case of non payment of an invoice, the unpaid amounts will be increased by 15% with a €250.00 minimum, by rights and without formal demand, as fixed compensation for the undergone damage (administrative expenses, reminders). No contestation or claim permits the suspension of payments. These measures apply without prejudice to the right to demand the payment of a higher amount of compensation in order to cover any undergone damage.

DELIVERY: The delivery takes place in WELL PUMPS 'premises. The buyer shall assume all risks related to the goods sold as from the moment of delivery, in particular those related to transport, even in the case of WELL PUMPS being in charge of the transportation or of its organization. The buyer takes delivery of the goods within a ten calendar day period starting as from the notice informing that the goods are available. The delivery is deemed to be completed the day after the expiration of the aforementioned ten calendar day limitation period. Except express guarantee, the delivery deadlines are only given by approximation. Delays cannot, under any condition, justify either the cancellation of the order or the payment of an indemnity. The liability of WELL PUMPS can only be involved in the event of serious delivery delay attributable to its serious fault. In case of repeated delivery to a closed door, return delivery costs to WELL PUMPS will be at the customer's expense. After opening and checking contents of the delivery, the customer must sign the delivery receipt presented by the seller or the carrier. This signature is deemed as an acceptance of products delivered by the buyer. In case of damage, it is up to the buyer to refuse the damaged product to the carrier who will return the shipment to WELL PUMPS. The customer should indicate legibly on the delivery slip the cause of the refusal as well as the number of parcels refused. Both the carrier and WELL PUMPS must be informed of the concerns of the customer by registered letter with an acknowledgement of receipt, within three days of reception, indicating the order reference number and the reasons of refusal. If damage shall be established, the good will be replaced by WELL PUMPS in a timely manner.

PROPERTY RESERVE: The supplied goods remain the property of WELL PUMPS until the complete payment of the price and the delivery costs, which can be increased by possible expenses and interests. This property reserve also applies in the event of any required processing or incorporation of the goods. Should the buyer fails in the complete payment, and/or if the buyer does not take delivery of the goods on the agreed date or within the agreed period, WELL PUMPS can, within a twenty calendar day period after the delivery, by rights and without formal notice, dissolve the contract and demand the return of the good supplied, regardless to their actual whereabouts. In this case, any advances will remain the property of WELL PUMPS without any equivalent concession for the buyer.

GUARANTEE: WELL PUMPS guarantees its goods against hidden defects for a twelve month period starting as from the delivery date, according to the following conditions: the guarantee can be implemented only if the following conditions are combined: **1** The defect renders the goods sold unfit for the use for which they are intended; **2** the material was erected and placed in an appropriate way; **3** the material is used under normal conditions. The guarantee does not apply in case of neglect, of modification, of dismantling or of repair of devices by an unqualified person. Under penalty of loss of rights, the beneficiary of the warranty must place his/her complaint related to the hidden defects which, according to him/her, affect the purchased goods, by registered letter within a one month period following the day he/she noticed should have noticed the any defects. Past this period, the guarantee becomes invalid. The guarantee of WELL PUMPS is limited, according to the choice of the latter, to either the free of charge merchandise repair or to replacement of defective equipment, to the exclusion of the resolution of sale and of any compensation. The buyer sends back, at his own risk and expense, the defective material to WELL PUMPS' headquarters in order for the repair or replacement to take place. These costs are only covered by WELL PUMPS if there is evidence that the under guarantee device is really defective.

REPARATION: All repairs will be quoted for the cost of the repair. The fees of the quotation are fixed at a flat rate of 75,00 , excluding VAT, which is payable in advance at the handing in goods at WELL PUMPS' premises. Upon verification of the goods and only in case of a defect of the goods covered by the guarantee, the client will automatically be refunded of the flat rate. Following the approval of the quotation, a repair order is tabled and signed by the buyer before repairing or maintaining the goods. The repair costs are immediately paid by the buyer, before any reparation. In case of no taking delivery of the repaired goods by the buyer on the agreed date or within the agreed period in the quotation, the handed in goods shall be deemed abandoned, by rights and without formal notice, and become the exclusive property of WELL PUMPS after a twenty calendar day period following the date of WELL PUMPS' registered mail requesting to reacquire the material possession of the repaired goods.

CANCELLATION: Except in the event of force majeure, the buyer can only cancel a firm order with the agreement of WELL PUMPS and in return of a financial compensation due to the damage undergone, which is expressly estimated at 30,00 % of the amount of the order, as long as the WELL PUMP does not opt for a forced execution, without prejudice of possible damages and interest.

DISPUTES: In case of dispute, only Belgian law shall apply, to the exclusion of the provisions of the Convention of Vienna concerning the international sale of goods. Any dispute between the customer and WELL PUMPS shall be exclusively placed in the competent hands of the courts of the judicial district of Mons and Charleroi, division of Charleroi in Belgium.

ACCEPTATION DES PRESENTES CONDITIONS GENERALES DE VENTE : Il ne peut être passé commande que si l'ensemble des présentes dispositions sont acceptées. Toute commande est exclusivement régie par ces conditions générales de vente, à l'exclusion de toute autre condition d'achat. Les présentes conditions générales sont jointes à la confirmation de commande et sont réputées acceptées si aucune contestation explicite n'en est donnée dans les trois jours. Le fait pour l'acheteur de ne pas prendre connaissance des conditions générales de WELL PUMPS dans sa langue maternelle ne peut altérer leur opposabilité à son égard.

OFFRE ET COMMANDE : Le délai de validité des offres de WELL PUMPS est de deux mois. Toute commande non précédée d'une offre écrite de WELL PUMPS et acceptée sans conditions, ne liera cette dernière que si elle a été acceptée par écrit. Les agents ou représentants de WELL PUMPS ne disposent pas d'un pouvoir de représentation.

PRIX : Les prix de WELL PUMPS sont libellés en euros, TVA non comprise. Toute augmentation de la TVA ou toute nouvelle taxe qui serait imposée entre le moment de la commande et celui de la livraison est à charge de l'acheteur. Ces prix s'entendent pour une livraison au siège de Charleroi sis Avenue de Lambusart 18 à BE-6220 Fleurus. Des frais d'expédition s'ajoutent au prix des marchandises si l'acheteur demande à WELL PUMPS de prendre en charge leur transport. Les prix ne visent que la fourniture de marchandises, à l'exclusion de tous autres travaux et prestations, et en particulier du placement et du montage qui peuvent s'ajouter au prix de la marchandise.

PAIEMENT : Sauf convention expresse contraire, les factures de WELL PUMPS sont payables à son siège social, dans les 30 jours de leur émission. Toute somme impayée à son échéance porte de plein droit et sans mise en demeure un intérêt au taux légal prévu par la Loi belge du 2 août 2002 transposant la directive Européenne 2000/35/CE concernant la lutte contre le retard de paiement en matière commerciale. En cas de non-paiement d'une facture à son échéance, les montants impayés seront majorés de 15 % avec un minimum de 250,00 €, de plein droit et sans mise en demeure, à titre d'indemnité forfaitaire pour le préjudice subi (frais administratifs, rappels,...). Aucune réclamation ou contestation n'autorise la suspension des paiements. Ces dispositions s'appliquent sans préjudice du droit d'exiger le paiement d'une indemnité supérieure pour le dommage réellement subi.

LIVRAISON : La livraison s'opère en les établissements de WELL PUMPS. L'acheteur supporte tous les risques relatifs aux marchandises vendues dès leur livraison, en particulier ceux relatifs au transport, même si WELL PUMPS se charge de celui-ci ou de son organisation. L'acheteur prend livraison des marchandises vendues dans les dix jours calendrier au plus tard à compter de l'expédition de l'avis l'informant qu'elles sont à sa disposition. La livraison est réputée accomplie à l'expiration de ce délai de dix jours. Sauf garantie expresse, les délais de livraison ne sont donnés qu'à titre indicatif. Des retards ne peuvent en aucun cas justifier l'annulation de la commande ni le paiement d'indemnités. La responsabilité de WELL PUMPS ne peut être engagée qu'en cas de retard important et imputable à sa faute lourde. L'envoi refusé ou non expédié à destination par suite d'absence répétée et prolongée du destinataire est renvoyé à WELL PUMPS aux frais de l'acheteur. Celui-ci s'engage, après ouverture et vérification du contenu du colis, à signer le récépissé de livraison présenté par le vendeur ou le transporteur. Le fait de signer le bon de livraison vaut acceptation expresse des produits livrés par l'acheteur. En cas d'avarie, l'acheteur doit refuser le produit abîmé au transporteur qui le retournera chez WELL PUMPS, et indiquer lisiblement sur le bon de livraison la cause du refus ainsi que le nombre de colis refusés. Les réserves doivent être notifiées au transporteur et à WELL PUMPS, dans les trois jours suivant la réception du produit, par lettre recommandée avec accusé de réception en indiquant la référence de la commande et les raisons du refus. Si l'avarie est avérée, WELL PUMPS procède à l'échange dans les meilleurs délais.

RESERVE DE PROPRIETE : Les marchandises fournies restent la propriété de WELL PUMPS jusqu'à parfait paiement du prix et des frais de livraison, majorés des frais et intérêts éventuels, et ce même en cas de transformation ou d'incorporation des marchandises.

A défaut de paiement, intégral ou partiel, et/ou si l'acheteur ne prend pas livraison des marchandises commandées à la date ou dans le délai de livraison convenu, WELL PUMPS peut, 20 jours calendrier après la livraison, de plein droit et sans mise en demeure, procéder à la résolution du contrat intervenu et réclamer les marchandises fournies en retour, entre quelques mains qu'elles se trouvent. Dans ce cas, les acomptes payés par l'acheteur restent acquis à WELL PUMPS, sans aucune contrepartie dans le chef de l'acheteur.

GARANTIE : WELL PUMPS garantit ses marchandises contre les défauts cachés pendant une période de douze mois à dater de la livraison, aux conditions qui suivent. La garantie ne peut être mise en œuvre que si les conditions suivantes sont réunies : **1** le défaut rend, dans une mesure importante, le bien vendu impropre à l'usage auquel il est habituellement destiné, **2** le matériel a été monté et placé de manière appropriée, **3** le matériel est utilisé dans des conditions normales. La garantie ne s'applique pas en cas de mauvais entretien, de modification, de démontage ou de réparation de l'appareil par une personne non qualifiée. A peine de déchéance de la garantie, l'acheteur motive les réclamations relatives aux défauts cachés qui, selon lui, affectent les marchandises vendues, par lettre recommandée dans un délai maximum d'un mois après qu'il ait constaté ou aurait dû normalement constater les défauts. Passé ce délai, la garantie n'est plus due. La garantie de WELL PUMPS est limitée, selon le choix de cette dernière, à la réparation gratuite ou au remplacement du matériel effectivement défectueux à l'exclusion de la résolution de la vente et de tous dommages et intérêts. L'acheteur renvoie à ses frais et à ses risques le matériel défectueux au siège de WELL PUMPS afin qu'il soit procédé à sa réparation ou à son remplacement. Ceux-ci ne sont supportés par WELL PUMPS que si l'appareil auquel la garantie d'applique se révèle être effectivement défectueux.

REPARATION : Pour toute réparation, les frais relatifs à l'établissement d'un devis sont fixés à la somme forfaitaire de 75,00 € HTVA, payable à l'avance, dès le dépôt du matériel dans les établissements de WELL PUMPS. Après examen, ce montant forfaitaire sera restitué au client uniquement dans l'hypothèse d'un vice affectant le matériel couvert par la garantie. En cas d'accord sur le devis, un ordre de réparation est établi préalablement à la réparation ou à l'entretien et signé par le client. Le montant des réparations est immédiatement payé par le client, préalablement à toute réparation. Dans l'hypothèse où le client ne prendrait pas livraison du matériel à la date ou dans le délai prévu dans le devis de réparation, le matériel déposé et/ou réparé sera considéré comme abandonné et deviendra de plein droit et sans mise en demeure, la propriété de WELL PUMPS 20 jours calendrier après l'envoi par WELL PUMPS d'une lettre recommandée enjoignant au client de reprendre possession de l'appareil réparé.

ANNULATION : Sauf cas de force majeure, l'acheteur ne peut annuler une commande ferme qu'avec l'accord de WELL PUMPS et moyennant dédommagement de celle-ci pour le préjudice subi, estimé de convention expresse à 30 % du montant de la commande, à moins que WELL PUMPS n'opte pour l'exécution forcée, sans préjudice de dommages et intérêts éventuels.

LITIGES : En cas de litige, le droit belge est seul applicable à l'exclusion de la Convention de Vienne sur la vente internationale de marchandises. Tout litige entre le client et WELL PUMPS relève de la compétence exclusive des tribunaux de l'arrondissement judiciaire de Mons et de Charleroi, division Charleroi, en Belgique.



Well Pumps S.A.
Avenue de Lambusart 18
6220 Fleurus, Belgium
Tel: + 32 71 46.07.83

Well Pumps Portugal Lda.
Rua Dr. Francisco Sa Carneiro, 597, frac. M
Zona Industrial do Bouro
4740-010 Esposende, Portugal
Tel: +351 253 46.88.29

info@wellpumps.eu
www.wellpumps.eu



AUTHORIZED DEALER